

USER MANUAL

RF 10/25

Revision 6.00

5708566-A

October 1999

Advanced Energy Industries, Inc.

1625 Sharp Point Drive
Fort Collins, CO 80525 USA
970.221.4670

technical.support@aei.com





**RF POWER SUPPLY
OPERATOR'S MANUAL**

**RF SERIES 10/25
REVISION 6.00**

**DOCUMENT NUMBER
21-22303-901**

**© COPYRIGHT 1996 RFPP, INC.
1007 LAUREL OAK ROAD VORHEES, NEW JERSEY 08043
ALL RIGHTS RESERVED 1996**

DOCUMENT: RF Power Supply Operator's Manual
RF SERIES 10/25, REVISION 6.00

DOCUMENT No.: 21-22303-901

ENGINEERING APPROVAL: Mike Kelly

CUSTOMER SERVICE APPROVAL: Rene Clement

QA APPROVAL: Monica DeMarco

REV	DATE	APPROVAL	REVISION DESCRIPTION
0	9/27/97	Mike Kelly	Released per EPR 430.
A	7/22/97	Mike Kelly	Analog pulse mode section changed per ECN 3468.
B	11/13/97		Word correction, pg 12 per ECN 3670.

TABLE OF CONTENTS

SECTION I	GENERAL INFORMATION.....	2
1.1	INTRODUCTION.....	2
1.2	PURPOSE.....	2
1.3	RATED POWER.....	2
1.4	GENERAL DESCRIPTION.....	2
1.5	THE FRONT PANEL.....	3
1.5.1	POWER.....	3
1.5.2	RF ON/OFF BUTTON.....	3
1.5.3	MULTIFUNCTION BUTTONS.....	3
1.6	REAR PANEL CONTROLS AND CONNECTIONS.....	3
1.6.1	CIRCUIT BREAKER.....	3
1.6.2	AC INPUT.....	3
1.6.3	CEX IN.....	3
1.6.4	CEX OUT.....	3
1.6.5	POWER/VOLTAGE* AND RF/DC* INPUTS.....	4
1.6.6	PRESET INVOKE*.....	4
1.6.7	PP0, PP1, AND PP2.....	4
1.6.8	EXTINLK.....	4
1.6.9	GATE.....	4
1.6.10	RAMP ENABLE*.....	5
1.6.11	RFON*.....	5
1.6.12	RFENABLED*.....	5
1.6.13	GATE ENABLE*.....	5
1.6.14	+15V.....	5
1.6.15	-15V.....	5
1.6.16	+5V.....	5
1.6.17	INCMON/MP1.....	7
1.6.18	REFMON/MP2.....	7
1.6.19	RF PROBE.....	7
1.6.20	DC PROBE.....	7
1.6.21	AUX PROBE.....	7
1.6.22	FBL - FEEDBACK LOW.....	7
1.6.23	SETPOINT #1.....	7
1.6.24	SETPOINT #2.....	8
1.6.25	GROUND SENSE.....	8
1.6.26	REMOTE LIMIT IN.....	8
1.6.27	REMOTE LIMIT OUT SHIELD CONNECTION.....	8
1.6.28	SHIELD CONNECTION.....	8
1.7	TECHNICAL SPECIFICATIONS.....	11
1.8	STANDARD ACCESSORIES.....	14
1.8.1	AC LINE CORD.....	14
1.8.2	PROGRAMMING PLUG.....	14
1.9	FACTORY REPAIR.....	14

TABLE OF CONTENTS

SECTION II	INSTALLATION AND OPERATION.....	15
2.1	GENERAL	15
2.2	UNPACKING	15
2.3	INSTALLATION.....	16
2.3.1	GROUNDING	16
2.3.1	LINE TAPS.....	16
2.3.3	WATER COOLED SUPPLIES	16
2.3.4	THERMAL CONSIDERATIONS.....	17
2.3.5	CHECKOUT.....	19
2.4	OPERATIONAL DESCRIPTION	21
2.4.1	PANEL MODE.....	21
2.4.2	ANALOG MODE.....	23
2.4.3	ANALOG PULSE MODE.....	26
2.4.4	SERIAL CONTROL.....	28
2.4.4.1	232 INTERFACE OPTION.....	28
2.4.4.2	422 INTERFACE OPTION.....	28
2.4.4.3	RFPP MULT-DROP PROTOCOL.....	29
2.4.4.4	485-WIRE AND 485-WIRE OPTIONS.....	31
2.4.4.5	422, 485-2 AND 485-4 BUS TERMINATIONS	31
2.5	MULTI-GENERATOR OPERATION.....	36
2.5.1	CALIBRATION PROCEDURE FOR DUAL GENERATOR SYSTEM	36
2.5.2	CALIBRATION PROCEDURE FOR QUAD GENERATOR SYSTEM.....	37
SECTION III	FRONT PANEL PROGRAMMING	41
3.1	STATUS ENVIRONMENT AND ADJUSTMENT BUTTONS.....	41
3.2	PROGRAMMING ENVIRONMENT AND PROGRAM BUTTON	41
3.3	MOVEMENT WITHIN THE PROGRAMMING ENVIRONMENT	42
3.4	FRONT PANEL PARAMETER PROGRAMMING.....	42
3.5	STATUS ENVIRONMENT MNEMONICS	44
3.5.1	CONTROL.....	44
3.5.2	OPERATIONAL MODE.....	44
3.5.3	EXT CEX.....	44
3.5.4	PULSING/RAMPING/PROGRAMMABLE PRESETS	45
3.6	ALARM AND LIMIT CONDITION MNEMONICS.....	45
3.6.1	RF OFF ALARM AND LIMIT MNEMONICS	45
3.6.1.1	COVER INTERLOCK ALARM (4 SPACES).....	45
3.6.1.2	EXTERNAL INTERLOCK ALARM (4 SPACES)	45
3.6.1.3	PA UNBALANCE/FAN/TEMP ALARM (4 SPACES).....	45
3.6.1.4	HIGH OR LOW LINE VOLTAGE ALARM (12 SPACES).....	46
3.6.2	RF ON ALARM AND LIMIT MNEMONICS.....	46
3.6.2.1	MAX POWER LIMIT (5 SPACES).....	46
3.6.2.2	REF LIMIT (6 SPACES).....	46
3.6.2.3	PA CURRENT LIMIT (4 SPACES)	46
3.6.2.4	POWER DISSIPATION/RF OUTPUT ALARM (5 SPACES).....	46

TABLE OF CONTENTS

3.7 PROGRAMMING ENVIRONMENT COLUMNS	47
3.7.1 ANALOG COLUMN	47
3.7.2 PRESETS COLUMN.....	49
3.7.3 PULSING COLUMN.....	51
3.7.3.1 A WORD ON PROGRAMMING START PULSE PARAMETERS.....	53
3.7.4 OPERATE COLUMN	56
3.7.5 SYSTEM COLUMN.....	59
SECTION IV PRESETS.....	61
4.1 INTRODUCTION.....	61
4.2 PRESET PARAMETERS	61
4.3 PRESET OPERATION.....	63
4.3.1 INDIVIDUAL PRESETS	63
4.3.2 SEQUENTIAL PRESETS	63
4.3.3 PRESETS AND MULTI-GENERATOR SYSTEMS.....	64
4.4 PROGRAMMING PRESETS	65
4.4.1 PANEL PROGRAMMING OF PRESETS	65
4.4.2 SERIAL PROGRAMMING OF PRESETS.....	67
4.5 EXECUTING PRESETS.....	67
4.5.1 PANEL.....	67
4.5.2 ANALOG.....	67
4.5.3 SERIAL.....	70
4.6 PRESET CLOCK.....	71
ADDENDUMS	
SECTION V SERIAL PROGRAMMING	CONSULT RFPP
SECTION VI FRONT PANEL SERVICING OF THE GENERATOR.....	CONSULT RFPP

LIST OF TABLES

TABLE 1	ANALOG INTERFACE PIN LIST	9
TABLE 2	TECHNICAL SPECIFICATIONS.....	11
TABLE 3	RF SERIES 10/25 PROGRAMMING ENVIRONMENT COLUMNS.....	43

LIST OF FIGURES

FRONT PANEL DIAGRAM	1
ANALOG INTERFACE CONNECTOR	6
WATER FITTINGS ILLUSTRATION.....	18
CHECKOUT CONFIGURATION	20
PANEL OPERATION.....	22
FULL ANALOG DCV OPERATION CONFIGURATION	24
FULL ANALOG DCV OPERATION WITH MATCHING NETWORK PRESETS.....	25
ANALOG PULSE MODE	27
DB25/DB9 PINOUTS	30
SERIAL CABLES	
232 AND 485 2-WIRE CONTROLLER CONNECTIONS.....	32
485 4-WIRE OR 422 CONNECTIONS.....	33
MULTI-DROP BUS LAYOUT	34
SINGLE DROP BUS LAYOUT	35
DUAL GENERATOR CONFIGURATION	38
QUAD GENERATOR CONFIGURATION	39
LIMIT POT ADJUSTMENT LOCATION	40
PROCESS PULSE/ START PULSE TIMING.....	54
PRESET TIMING	62
DUAL GENERATOR PRESET CONNECTION	68
FULL ANALOG DCV WITH PRESET CONNECTIONS	69
APPENDIX A.....	72

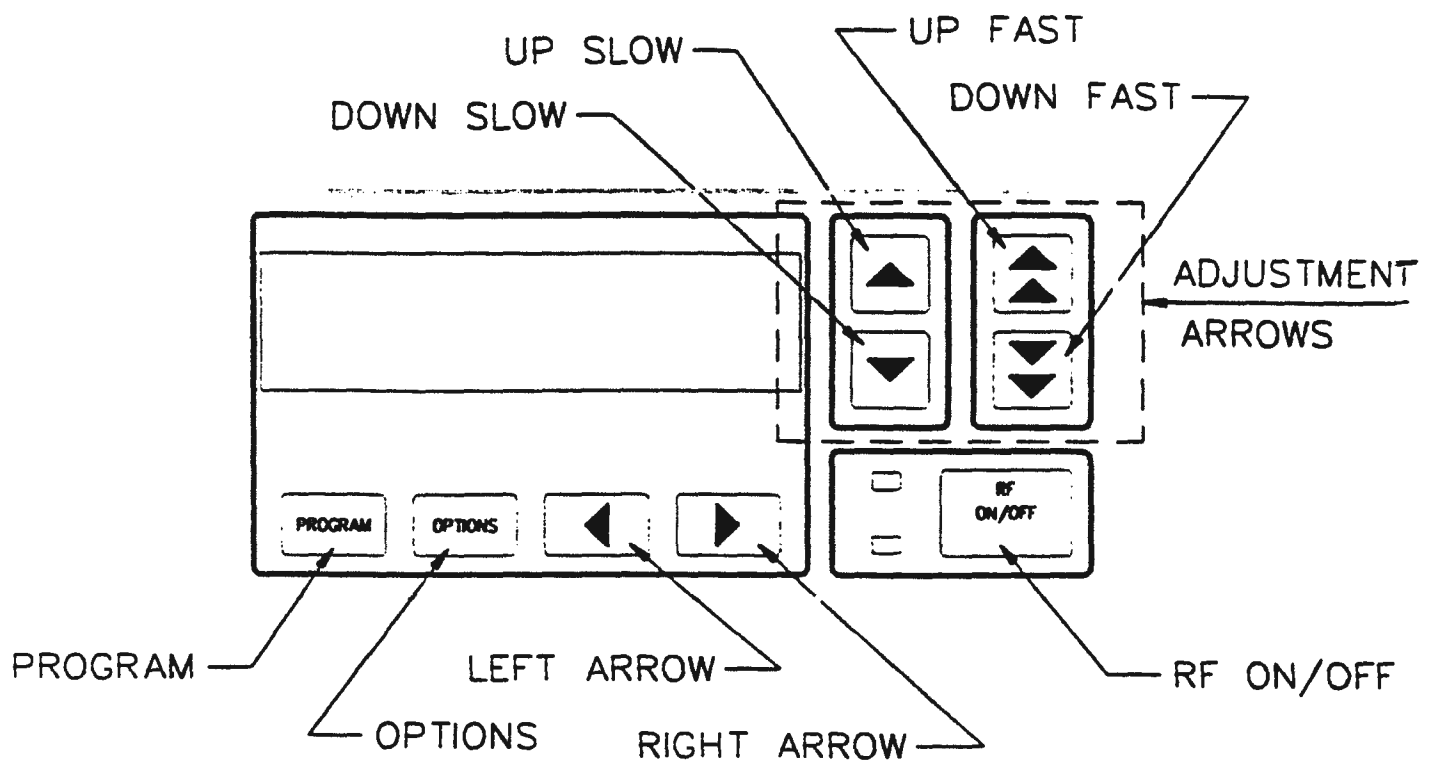

FIGURE 1
FRONT PANEL DIAGRAM

SECTION I

GENERAL INFORMATION

1.1 INTRODUCTION

This volume provides the operating instructions for the RF and HF series generators (also referred to as the generator, the unit, the equipment, the RF supply or the supply), manufactured by RFPP Inc., Voorhees, New Jersey. This volume discusses the purpose, application and technical characteristics of the generator.

WARNING: This power supply operates using lethal voltages and is capable of producing hazardous RF voltages. **DEATH ON CONTACT** may result from failure to observe **SAFETY** precautions. When working inside the equipment, make certain the RF power supply is disabled at the wall disconnect.

In the unlikely event that operation of the RF power supply is required with access covers removed, do not allow body contact with any electrical component, tap, terminal or connection. Use only heavily insulated tools and test equipment to make measurements and adjustments.

1.2 PURPOSE

The generator is a unique microprocessor based RF power supply designed to provide the user with a flexible set of options for control. The supply provides the user with a pure, stable power source from 0 to the generator's rated power.

1.3 RATED POWER

RF5	---	500 Watts	RF20	---	2000 Watts
HF5	---	500 Watts	RF20H	---	2000 Watts
RF10	---	1000 Watts	RF30	---	3000 Watts
HF10	---	1000 Watts			

1.4 GENERAL DESCRIPTION

With RF ON, forward and reflected power are shown on the top line of the Vacuum Fluorescent Display (VFD). With RF OFF, setpoint and max power are shown on the top line of the VFD. Additional generator status information is typically displayed on the bottom line of the VFD. Blinking mnemonics on the bottom line of the VFD convey limit or alarm conditions as well as the quality of the match.

The generator is a simple stand alone RF power supply in the PANEL mode. PANEL mode is front panel operation. Power level is set via the four adjustment arrow buttons on the front panel. Feedback for the high speed regulating circuits is supplied by the internal directional coupler (power control) or, for CPU controlled regulation, the selected feedback terminal (voltage control). For more on panel programming, see Section III in this manual.

The ANALOG control mode allows control of the generator via external analog and digital control signals.

The SERIAL control mode is the most flexible mode of control. The unit can be configured to operate in this mode with a minimum number of external connections to the system controller. Under SERIAL control the supply may be configured, power level set and status monitored over a simple serial link.

1.5 THE FRONT PANEL

1.5.1 POWER

This is the AC power switch for the generator.

1.5.2 RF ON/OFF BUTTON

When RF is ON, this button is **always active** and turns RF OFF if momentarily depressed.

When RF is OFF and front panel RF ON is permitted, this button turns RF ON if momentarily depressed.

1.5.3 MULTIFUNCTION BUTTONS

There are 8 additional tactile buttons called ADJUSTMENT ARROWS on the front panel of the generator. These multifunction buttons (4 below the VFD and 4 to the right of the VFD) are explained in detail in Section III (PANEL PROGRAMMING) of this manual.

1.6 REAR PANEL CONTROLS AND CONNECTIONS

1.6.1 CIRCUIT BREAKER

The circuit breaker provides overcurrent protection for the power supply. It **DOES NOT** provide short circuit protection. An additional breaker with high current interrupt capacity or a set of fuses should be included in the system for safety. This breaker is the AC main disconnect for the generator. To operate the supply, place the lever in the up position.

1.6.2 AC INPUT

Attach included line cord to unit.

1.6.3 CEX IN

Common exciter input for applications requiring synchronous operation of RF generators. The source can be another RF supply or CEX product. Input impedance is 50 Ohms and the required level is 7-20 volts P-P at the operating frequency.

1.6.4 CEX OUT

Common exciter output for applications requiring synchronous operation of RF generators. The signal is compatible with CEX input of RF supplies. Output impedance is 50 Ohms and the level is 8 volts P-P at the operating frequency.

NOTE: The following items all refer to ANALOG interface (38 pin ELCO connector). Refer to Figure 2 and Table 1.

1.6.5 POWER/VOLTAGE* AND RF/DC* INPUTS

These inputs are used to select the control modes.

PWR/VLT*	RF/DC*	CONTROL SELECTED
H	H	Forward Power Control
H	L	AUX Voltage Channel
L	H	RF Voltage Channel
L	L	DC Voltage Channel

H = +5V or open pin L = Ground or low logic level

1.6.6 PRESET INVOKE*

In ANALOG operation PRESET INVOKE* is the invoke selected preset function. Pulling this pin from a high to a low level will enable the preset selected by programming pins PP0, PP1 and PP2. Note that a high to low TRANSITION is needed to invoke the selected preset. The input is TTL compatible.

1.6.7 PP0, PP1 and PP2

These pins form a truth table that selects a preset in the following manner ...

PP2	PP1	PP0	SELECTS
L	L	L	Preset # 0
L	L	H	Preset # 1
L	H	L	Preset # 2
L	H	H	Preset # 3
H	L	L	Preset # 4
H	L	H	Preset # 5
H	H	L	Preset # 6
H	H	H	Presets Disabled

H = +5V or open pin L = Ground or low logic level

Refer to Section IV and Figure 17.

1.6.8 EXTINLK

External interlock is the system interlock. To enable RF, the EXTINLK pin must be grounded. An open interlock will result in RF output being disabled.

1.6.9 GATE

In ANALOG operation, apply a pulse train to this terminal to operate the unit as a pulsed RF generator. At the time of the transition of the pulse train from low to the high level, the output power will be selected by the setpoint # 2 level. On the high to low transition, the power will be selected by the setpoint # 1 level. Refer to Section 2.4.2. ANALOG OPERATION. The input is TTL compatible.

1.6.10 RAMP ENABLE*

In ANALOG operation RAMP ENABLE is the RAMP AT RF ON function. Pulling this pin from a high to a low level enables ramping. The input is TTL compatible.

1.6.11 RFON*

In ANALOG operation RFON* is the RF ON/OFF function. Pulling this pin from a high to a low level enables RF. Note that a high to low transition is REQUIRED to turn RF ON. The input is TTL compatible.

1.6.12 RFENABLED*

RFENABLED* is a status line indicating that RF is ON, or RF is ON and OK. Alternatively, in the preset mode the logic is reversed and it becomes the PRESET ENABLE signal for the PS2A Matching Network Controller. Refer to Section 2.4.2.

NOTE: This is an open collector output.

1.6.13 GATE ENABLE*

Pulling this pin low enables the ANALOG pulse mode. The input is TTL compatible.

1.6.14 +15V

+15V is a positive 15 volt DC source whose designed purpose is to generate a positive external setpoint using an external 10k potentiometer in ANALOG operation. The unit must be programmed for positive polarity. See POLARITY PROGRAMMING. +15V has a 470 Ohm output resistance with a maximum allowable current draw of 15 mA.

1.6.15 -15V

-15V is a negative 15 volt DC source whose designed purpose is to generate a negative external setpoint using an external 10k potentiometer in ANALOG operation. The unit must be programmed for negative polarity. See POLARITY PROGRAMMING. -15V has a 470 Ohm output resistance with a maximum allowable current draw of 15 mA.

1.6.16 +5V

+5V has a maximum allowable current draw of 25 mA.

NOTE: RFPP does not recommend using the +15, -15 and +5 output voltages in new designs.

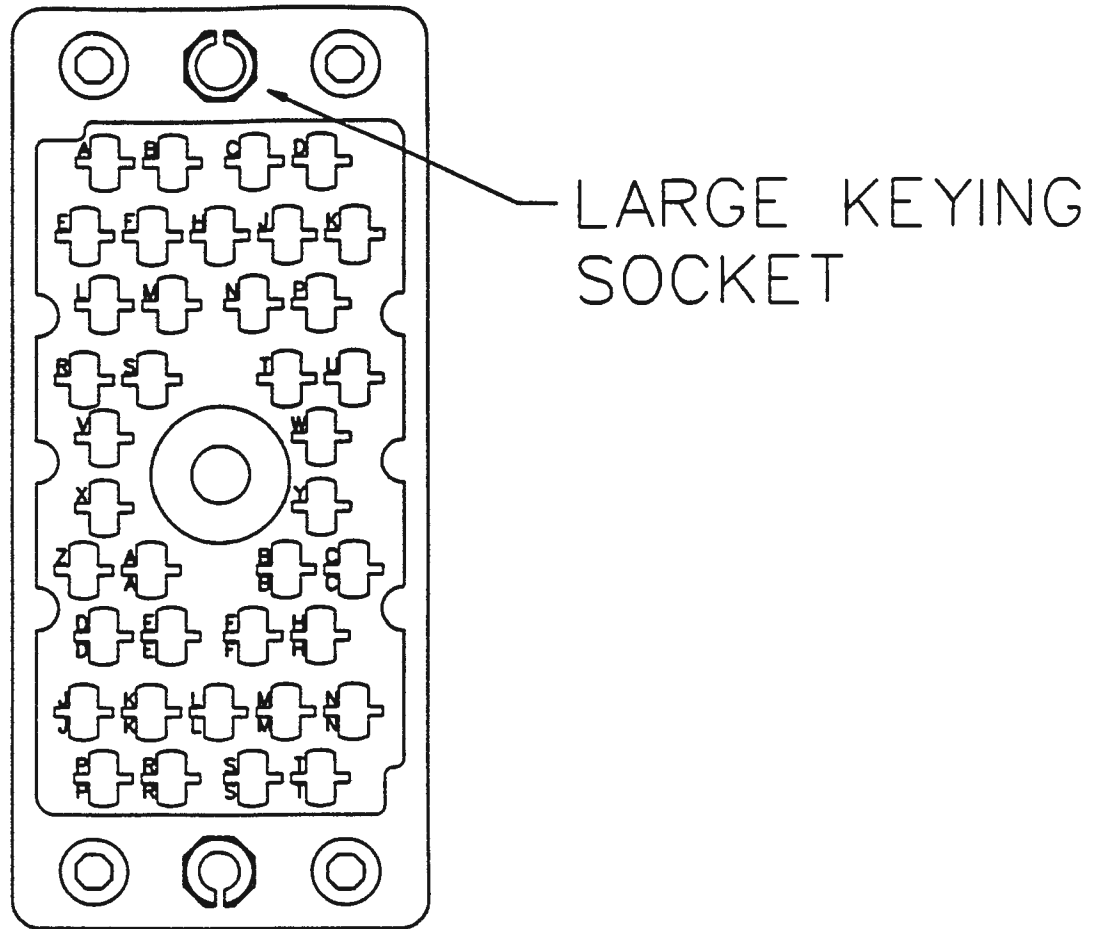

FIGURE 2
ANALOG INTERFACE CONNECTOR
(VIEW OF CONNECTOR FROM
REAR OF UNIT)

1.6.17 INCMON/MP1

INCMON is an analog output that has two functions. In the normal mode of operation there is a voltage present on this terminal that is linearly related to the forward power. The voltage is +5V at rated power. Accuracy is $\pm .5\%$ full scale $\pm 3\%$ reading; resolution is 1 Watt.

When the Load & Tune function is enabled, the terminal is a forward power monitor (above), while RF is ON, and a preset voltage for the tune capacitor in the AM-SERIES matching network when RF is OFF. Refer to Figure 7 and Section 2.4.2.

1.6.18 REFMON/MP2

REFMON is an analog output that has two functions. In the normal mode of operation there is a voltage present on this terminal that is linearly related to the reflected power. The voltage is +5V at 10% of rated power. Accuracy is $\pm .5\%$ full scale $\pm 3\%$ reading; resolution is 1 Watt.

When the Load & Tune function is enabled, the terminal is a reflected power monitor (above), while RF is ON, and a preset voltage for the load capacitor in the AM-SERIES matching network when RF is OFF. Refer to Figure 7 and Section 2.4.2.

1.6.19 RF PROBE

The feedback necessary for RF voltage control is applied to this terminal. The input is differential with an impedance of 47k Ohms. See Section 2.4.2 and Figures 6 & 7.

1.6.20 DC PROBE

The feedback necessary for DC bias voltage control is applied to this terminal. The input is differential with an impedance of 47k Ohms. See Section 2.4.2 and Figures 6 & 7.

1.6.21 AUX PROBE

The feedback necessary for AUX voltage control is applied to this terminal. The input is differential with an impedance of 47k Ohms. See Section 2.4.2 and Figures 6 & 7.

1.6.22 FBL - FEEDBACK LOW

The voltage control feedback channels can be factory configured as single-ended or differential. The aforementioned probe input terminals are all the HIGH inputs of a differential pair. The FBL terminal is the LOW side of all probe inputs when they are configured as differential inputs.

1.6.23 SETPOINT # 1

SETPOINT # 1 is the standard power and voltage setpoint input. In the power mode, the setpoint is linear over a ± 5 or ± 10 volt range from 0 to rated power. See RANGE and POLARITY PROGRAMMING. Input impedance is 47k Ohms. In the voltage control mode, the control loop will alter the power until the setpoint and feedback signals are equal. The voltage-setpoint/power transfer function is a function of the probe attenuation and load impedance.

NOTE: SETPOINT # 1 is also used as the high power level in ANALOG pulse operation.

1.6.24 SETPOINT # 2

SETPOINT # 2 is the secondary setpoint input. In ANALOG pulsed operation, the setpoint is linear over a ± 5 or ± 10 volt range from 0 to rated power. See RANGE AND POLARITY PROGRAMMING. Input impedance is 47k Ohms.

NOTE: This input is used as the low power level in ANALOG pulse operation.

1.6.25 GROUND SENSE

The GROUND SENSE line is the reference input for setpoint inputs and monitor outputs.

1.6.26 REMOTE LIMIT IN

The REMOTE LIMIT IN signal is designed to fold the generator back under external limit conditions. Typically this input is used in dual bias systems. Input impedance is 10k Ohms. See Section 2.5.

1.6.27 REMOTE LIMIT OUT

REMOTE LIMIT OUT is an analog signal which represents the level of reflected voltage sensed by the supply. The signal is not linearly related to reflected power. Typically it is used in dual bias systems. See Section 2.5.

1.6.28 SHIELD CONNECTION

SHIELD **MUST** be terminated at one end of the analog cable. Empirical testing may be required to determine the best termination point.

TABLE 1
ANALOG INTERFACE PIN LIST

<u>PIN</u>	<u>LABEL</u>	<u>FUNCTION</u>	<u>SIGNAL</u>	<u>DIRECTION</u>
A	POWER/VOLTAGE*	SELECT POWER OR VOLTAGE CONTROL	DIGITAL	INPUT
B	RF/DC*	SELECT RF OR DC VOLTS	DIGITAL	INPUT
CC	PRESET INVOKE*	INVOKES SELECTED PRESET (PP0, PP1 and PP2)	DIGITAL	INPUT
U	PP0	PRESET SELECT PIN 0	DIGITAL	INPUT
BB	PP1	PRESET SELECT PIN 1	DIGITAL	INPUT
FF	PP2	PRESET SELECT PIN 2	DIGITAL	INPUT
W	EXTINTLK	EXTERNAL INTERLOCK	DIGITAL	INPUT
S	GATE	GATE SIGNAL INPUT	DIGITAL	INPUT
DD	RAMP ENABLE*	RF ON RAMP ENABLE	DIGITAL	INPUT
F	RFON*	RF ENABLE	DIGITAL	INPUT
M	RFENABLED*	RF STATUS LINE	DIGITAL	OUTPUT
EE	GATE ENABLE*	ANALOG PULSING ENABLE	DIGITAL	INPUT
AA	EPO	EMERGENCY POWER OFF SWITCH CONTACT (OPTIONAL)	---	---
Z	EPO	EMERGENCY POWER OFF SWITCH CONTACT (OPTIONAL)	---	---
PP	+15V	+15 VOLTS	---	OUTPUT
TT	-15V	-15 VOLTS	---	OUTPUT
NN	+5V	+5 VOLTS	---	OUTPUT
H	INC MON/TUNE	INCIDENT POWER MONITOR	ANALOG	OUTPUT
J	REF MON/LOAD	REFLECTED POWER MONITOR	ANALOG	OUTPUT
C	RF PROBE	RF VOLTAGE FEEDBACK	ANALOG	INPUT

TABLE 1 cont.

ANALOG INTERFACE PIN LIST

<u>PIN</u>	<u>LABEL</u>	<u>FUNCTION</u>	<u>SIGNAL</u>	<u>DIRECTION</u>
D	DC PROBE	DC VOLTAGE FEEDBACK	ANALOG	INPUT
LL	AUX IN	AUXILIARY FEEDBACK	ANALOG	INPUT
T	FBL	FEEDBACK LOW	ANALOG	INPUT
E	SETPOINT # 1	POWER/VOLTAGE SETPOINT	ANALOG	INPUT
R	SETPOINT # 2	POWER/VOLTAGE SETPOINT	ANALOG	INPUT
V	GROUND SENSE	REFERENCE INPUT FOR CONTROL GROUND	ANALOG	IN/OUT
P	REMOTE LIMIT IN	EXTERNAL LIMIT INPUT	ANALOG	INPUT
Y	REMOTE LIMIT OUT	INTERNAL LIMIT OUTPUT	ANALOG	OUTPUT
N	SHIELD	SHIELD CONNECTION	---	---
L	GROUND	DIGITAL GROUND	---	---
RR	GROUND	DIGITAL GROUND	---	---
K	GROUND	DIGITAL GROUND	---	---
MM	Available	Formerly external PULL UP	---	---

1.7 TECHNICAL SPECIFICATIONS

TABLE 2

<u>REF #</u>	<u>PARAMETER</u>	<u>SPECIFICATION</u>
1	FREQUENCY	
	i) RF50, RF100, RF200, RF20H0 RF300	(S) 13.56 MHz \pm .01% (P) 27.12 MHz \pm .01% (L) 40.68 MHz \pm .01%
	ii) HF5, HF10	60.00 MHz \pm .01%
2	FREQUENCY STABILITY	\pm .005 % SHORT TERM.
3	RF OUTPUT POWER	RF5 500 Watts into 50 Ohms. HF5 500 Watts into 50 Ohms RF10 1000 Watts into 50 Ohms. HF10 1000 Watts into 50 Ohms. RF20 2000 Watts into 50 Ohms. RF20H 2000 Watts into 50 Ohms. RF30 3000 Watts into 50 Ohms.
4	OUTPUT IMPEDANCE	50 \pm 5 Ohms nominal.
5	METERING ACCURACY	Forward power \pm .5 % FS \pm 3% of reading.
6	STANDARD RF OUTPUT CONNECTOR	RF5 N HF5 N RF10 N HF10 N RF20 N RF20H HN RF30 DIN For additional RF output connector configurations, contact RFPP.
7	POWER STABILITY	\pm 1 Watt \pm 0.5% long term.
8	TEMPERATURE COEFFICIENTS OF POWER STABILITY	\pm 0.05% / C.
9	FORWARD POWER REGULATION	1% into 50 Ohm load.
9b	LINE REGULATION	Related to RMS line voltage. Within range of tap settings, all specifications will be met. Below 5% low line, derate max power 1.5% for every 1% line change to a minimum 18% low line. Unit not specified to operate below 190 VAC.
10	LOAD MISMATCH TOLERANCE	Continuous duty into any passive load without failure or oscillation.

TABLE 2 cont.

<u>REF #</u>	<u>PARAMETER</u>	<u>SPECIFICATION</u>																
11	HARMONIC DISTORTION	All harmonics more than 45 dB down (typ. 50 dB), reference to carrier.																
12	NOISE, HUM, RIPPLE	-40 dBC at full power.																
13	COMMON EXCITER INPUT	Input impedance 50 Ohms, 7-20 volts P-P at operating frequency.																
14	COMMON EXCITER OUTPUT	Output impedance 50 Ohms, 8 volts P-P at operating frequency.																
15	PROTECTION	Forward power limits on PA current or excessive reflected power ... <table border="0"> <tr> <td>RF5</td> <td>37 Watts</td> </tr> <tr> <td>HF5</td> <td>75 Watts</td> </tr> <tr> <td>RF10</td> <td>75 Watts</td> </tr> <tr> <td>HF10</td> <td>150 Watts</td> </tr> <tr> <td>RF20</td> <td>150 Watts</td> </tr> <tr> <td>RF20WC</td> <td>300 Watts</td> </tr> <tr> <td>RF20H</td> <td>700 Watts</td> </tr> <tr> <td>RF30</td> <td>450 Watts</td> </tr> </table> <p>... short and open circuit protected.</p>	RF5	37 Watts	HF5	75 Watts	RF10	75 Watts	HF10	150 Watts	RF20	150 Watts	RF20WC	300 Watts	RF20H	700 Watts	RF30	450 Watts
RF5	37 Watts																	
HF5	75 Watts																	
RF10	75 Watts																	
HF10	150 Watts																	
RF20	150 Watts																	
RF20WC	300 Watts																	
RF20H	700 Watts																	
RF30	450 Watts																	
16	SPURIOUS RADIATION	RF Series supplies meet or exceed FCC specifications.																
17	OPERATING AMBIENT	0 to 40 degrees Celsius.																
18	HUMIDITY	80% non-condensing.																
19	WATER FLOW/TEMPERATURE (Water Cooled Units)	<table border="0"> <tr> <td>HF10</td> <td>1.0 GPM</td> </tr> <tr> <td>HF5</td> <td>1.0 GPM</td> </tr> <tr> <td>RF20WC</td> <td>2.5 GPM</td> </tr> <tr> <td>RF20H</td> <td>2.5 GPM</td> </tr> <tr> <td>RF30</td> <td>2.5 GPM</td> </tr> </table> <p>All at 35° C max inlet temp.</p>	HF10	1.0 GPM	HF5	1.0 GPM	RF20WC	2.5 GPM	RF20H	2.5 GPM	RF30	2.5 GPM						
HF10	1.0 GPM																	
HF5	1.0 GPM																	
RF20WC	2.5 GPM																	
RF20H	2.5 GPM																	
RF30	2.5 GPM																	
20	AIR FLOW REQUIREMENTS (Air Cooled Units)	<table border="0"> <tr> <td>RF5</td> <td>100 cubic feet / minute</td> </tr> <tr> <td>HF5</td> <td>100 cubic feet / minute</td> </tr> <tr> <td>RF10</td> <td>220 cubic feet / minute</td> </tr> <tr> <td>RF20</td> <td>220 cubic feet / minute</td> </tr> </table>	RF5	100 cubic feet / minute	HF5	100 cubic feet / minute	RF10	220 cubic feet / minute	RF20	220 cubic feet / minute								
RF5	100 cubic feet / minute																	
HF5	100 cubic feet / minute																	
RF10	220 cubic feet / minute																	
RF20	220 cubic feet / minute																	

TABLE 2 cont.

<u>REF #</u>	<u>PARAMETER</u>	<u>SPECIFICATION</u>
21	POWER REQUIRED	RF5 99-125 VAC 50/60 Hz 1 ϕ 11 Amps 190-262 VAC 50/60 Hz 1 ϕ 6 Amps
		HF5 99-125 VAC 50/60 Hz 1 ϕ 11 Amps 190-262 VAC 50/60 Hz 1 ϕ 6 Amps
		RF10 190-262 VAC 50/60 Hz 1 ϕ 11 Amps
		HF10 190-262 VAC 50/60 Hz 3 ϕ 6 Amps
		RF20 190-262 VAC 50/60 Hz 3 ϕ 14 Amps 190-262 VAC 50/60 Hz 1 ϕ 28 Amps
		RF20H 190-262 VAC 50/60 Hz 3 ϕ 19 Amps
		RF30 190-262 VAC 50/60 Hz 3 ϕ 19 Amps
		RF5 (208V) 8 Amp overcurrent
		RF5 (115V) 15 Amp overcurrent
		HF5 (208V) 15 Amp overcurrent
22	CIRCUIT PROTECTION	RF10 15 Amp overcurrent
		HF10 8 Amp overcurrent
		RF20 3 ϕ 18 Amp overcurrent
		RF20 1 ϕ 38 Amp overcurrent
		RF20H 25 Amp overcurrent
		RF30 25 Amp overcurrent

1.8 STANDARD ACCESSORIES

1.8.1 AC LINE CORD

1.8.2 PROGRAMMING PLUG

The PROGRAMMING PLUG is the mate to the analog interface connector. A full complement of pins are supplied.

1.8.3 OPERATORS MANUAL

1.9 FACTORY REPAIR

When factory repair is desired, proceed as follows:

- 1) Document problem encountered.
- 2) Contact RFPP Customer Service Department for a FACTORY RETURN AUTHORIZATION NUMBER.

SECTION II

INSTALLATION AND OPERATION

2.1 GENERAL

This section contains the installation and operating procedure for the various generators. The operating functions, controls and indicators are described in detail.

2.2 UNPACKING

Retain all packing materials until it has been verified that no internal damage has occurred to the unit in shipping.

2.2.1

The RF5, HF5, RF10 and HF10 generators are shipped in a standard slotted carton with foam inserts. Unpack as follows:

- 1) Remove foam cap from unit.
- 2) Carefully remove unit from carton.
- 3) Remove plastic bag from around unit (RF5S only).
- 4) Discard packet of desiccant (RF5S only).
- 5) Inspect for possible damage incurred during shipping.
- 6) If damage exists, notify carrier and RFPP. Retain all shipping and packing materials. Do not return without instructions from RFPP.

2.2.2

The RF20, RF20H and RF30 generators are shipped in a wooden crate with foam inserts. Unpack as follows:

- 1) If the TIP-N-TELL shipment indicator, mounted on the exterior of the crate, indicates that the crate has been mishandled, notify the carrier and RFPP.
- 2) Carefully remove unit from crate.
- 3) If the DROP (N) TELL shipment indicator, mounted on the unit, indicates that the crate has been mishandled, notify the carrier and RFPP.
- 4) Inspect for possible damage incurred during shipping.
- 5) If damage exists, notify carrier and RFPP. Retain all shipping and packing materials. Do not return without instructions from RFPP.

2.2.3

Check the enclosed packing slip and final checklist to confirm that the shipment you have received (including accessories) is complete. If not, notify RFPP.

2.3 INSTALLATION

2.3.1 GROUNDING

Any RF system must be grounded (earthed) through a low impedance path to insure reliable operation and to minimize RF interference to other equipment. It is recommended that the installer ground the case of the generator (or the metal rack to which it is mounted) to a copper-clad ground stake driven at least 2 m (6 ft) into the earth. In a steel frame building, the building frame may also serve as ground. The connection from the generator to the ground should be as short and direct as possible through a copper strap at least 25mm (1 inch) wide. A brass bolt terminal marked with a ground symbol is provided on the rear of the generator for this connection.

The ground wire in the AC power cord is solely for electrical safety. It cannot be relied upon for RF grounding.

Poor grounding may allow RF voltages to exist on the equipment frame. This can cause RF interference to radiate into the air and to conduct back through the power lines. In either case, it is likely to impair the performance of sensitive electronic equipment and interfere with radio communications.

2.3.2 LINE TAPS

RFPP generators operate on 198-250 ($\pm 5\%$) VAC lines (the RF5 and HF5 may operate on 99-125 VAC lines). Therefore, it may be necessary to change the taps on the primary power transformer on site. Before installing in the system, carefully remove cover from generator (bottom on RF5 and HF5), then select the appropriate taps as shown in Appendix A.

2.3.3 WATER COOLED SUPPLIES

Connect fittings for water cooling. Connections are provided to accept 1/8 inch NPT male pipe fittings. An adapter is available that will accommodate 1/4 inch NPT male pipe fittings. The unit is designed to operate normally at the specified rate of coolant flow. See Table 2. If in doubt, or the available process water flow is near this flow rate, the actual flow should be checked. A minimum pressure installation should ideally use 5/8" inside diameter plumbing or hose, connected as closely as possible to the generator.

NOTE: The generator is protected against damage caused by lack of coolant flow. However, inadequate coolant flow will result in OVER TEMPERATURE condition and RF will be disabled until normal internal temperatures are restored.

The water used for cooling should be clean and free of any contaminants that may cause a buildup of corrosion or scale inside the heat sink tubing. This condition would reduce the electrical integrity of the supply by reducing the amount of cooling to the power transistors.

CAUTION: DO NOT apply excessive torque to the water inlet and outlet fittings on the rear of the generator. Avoid the use of excessive amounts of thread compound that may obstruct the cooling passages in the heat sink.

NOTE: Distilled water should be used, if possible, to eliminate lime or other mineral buildup in the copper components of the heat exchanger. If tap water with a high mineral content is used for cooling, it may be necessary to periodically flush the unit by pumping a commercial lime or scale removing agent through the system. Typically, this agent is a household or industrial product. The unit should be flushed for approximately 5 minutes or until the scale is entirely removed. For further recommendations, consult the factory.

2.3.4 THERMAL CONSIDERATIONS

Take care to observe the maximum ambient temperature specifications. Ensure proper ventilation of the cabinet that will enclose the operational power supply. RFPP recommends a 1 3/4 inch space above the unit for proper air flow. Free air flow is also required to the sides of the unit.

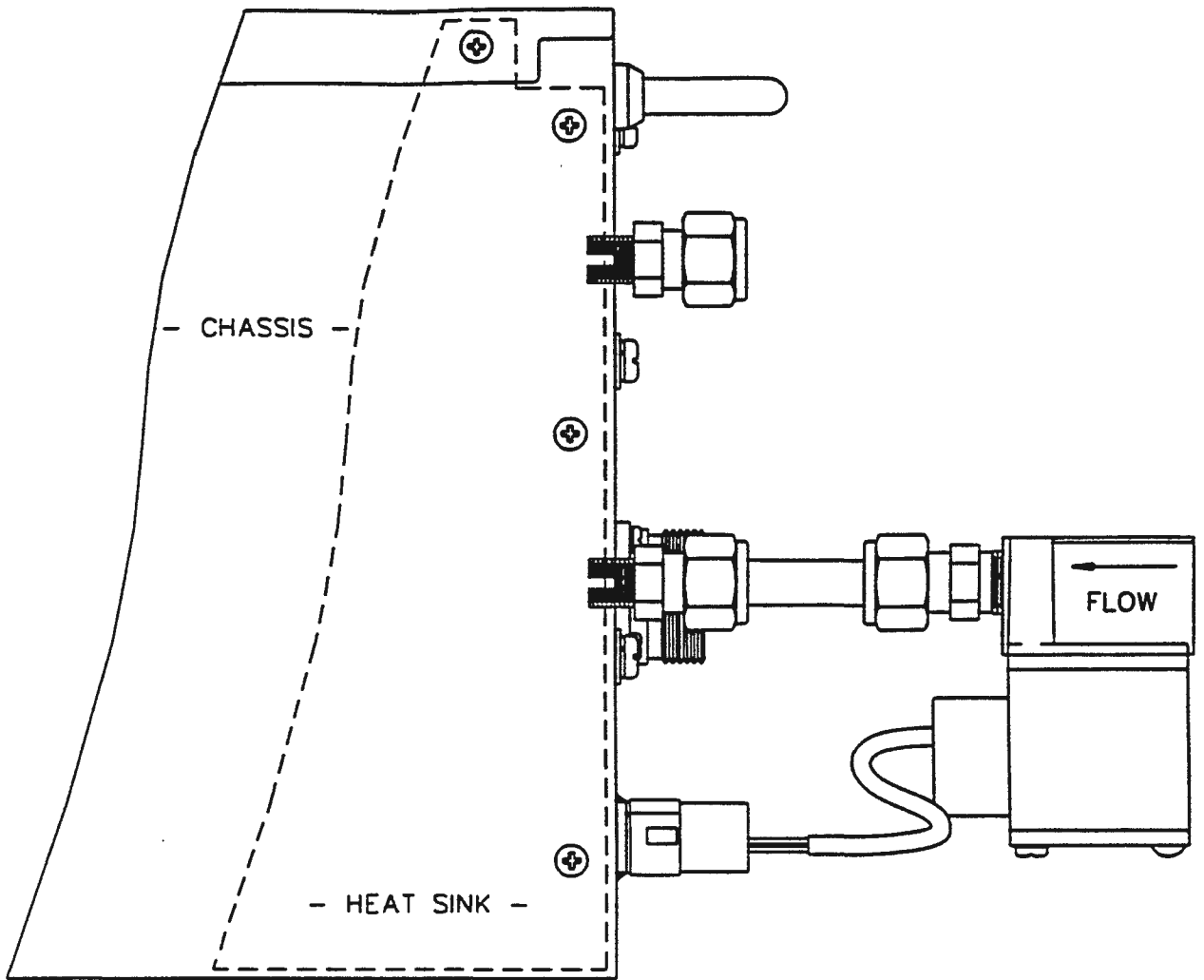

FIGURE 3
ILLUSTRATION - WATER FITTINGS/CONNECTIONS

2.3.5 CHECKOUT

If possible, upon receipt of the generator, check the operation of the generator into a 50 Ohm dummy load capable of handling up to 110% of the rated power of the generator. See Figure 4 for checkout configuration.

- 1) Connect AC line cord.
- 2) Connect programming plug as supplied by RFPP.
- 3) Connect unit to dummy load.
- 4) Turn RF on by depressing RF ON key on front panel. Unit should be capable of delivering rated power to the load.
- 5) Unit can now be configured for the particular application.

FIG 4 CHECKOUT CONFIGURATION

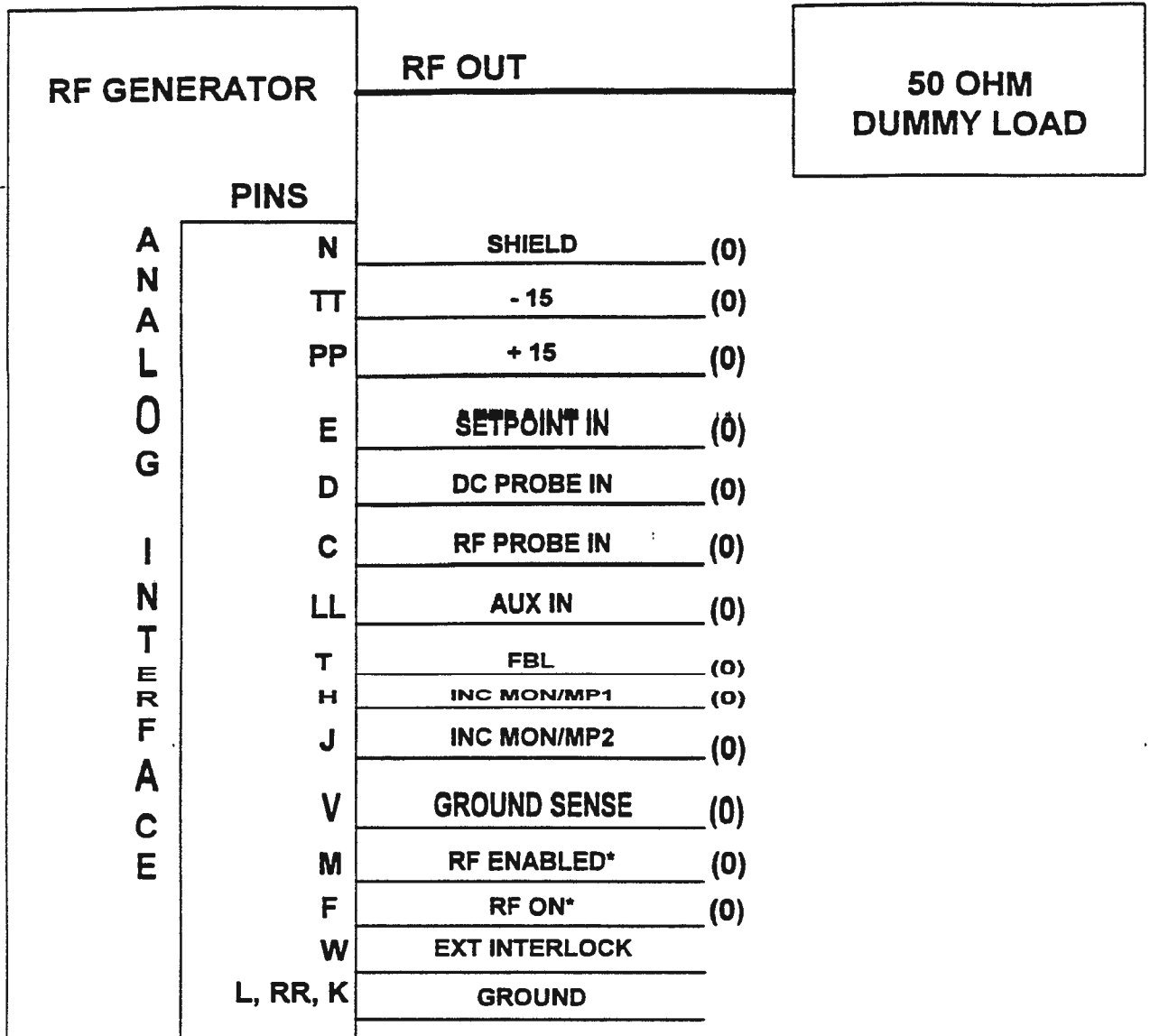

NOTES:

(0) INDICATES OPEN TERMINAL

*** INDICATES NEGATIVE LOGIC**

2.4 OPERATIONAL DESCRIPTION

It will be necessary to refer to Sections 1.6 and 3, Rear Panel Controls and Connections and Front Panel Programming respectively, during this discourse.

2.4.1 PANEL MODE

This is the simplest of the four modes of operation. Panel control utilizes the front panel for control of RF ON/OFF, setpoint and maximum power setting.

To configure the unit for PANEL control, set up as in Figure 5.

- 1) Connect RF output cable to matching network.
- 2) Connect programming plug. As shipped, the programming plug connects the external interlock to ground.
- 3) Remove ground and connect the interlock to the system interlock string, if required.
- 4) To set setpoint with RF off, use the ADJUSTMENT ARROWS on the front panel to position setpoint to the desired setting. The single arrows change setpoint slowly, while the double arrows allow for faster (larger increments) adjustments.
- 5) Depress RF ON/OFF button to turn RF on. Likewise, depress RF ON/OFF button to turn RF off.
- 6) Use adjustment arrows to adjust power to desired level.

FIG 5 PANEL OPERATION

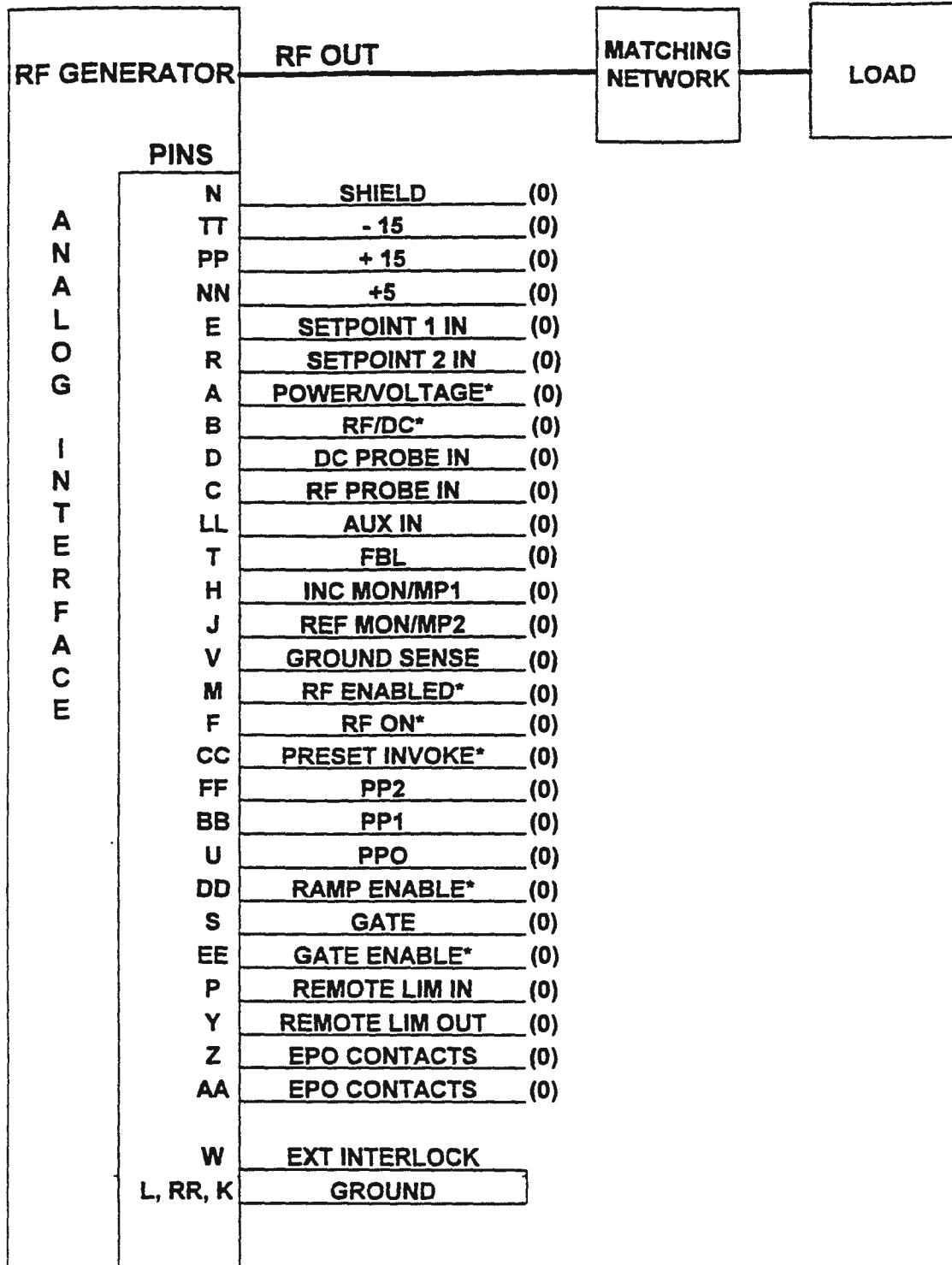

NOTES:

(0) INDICATES OPEN TERMINAL

* INDICATES NEGATIVE LOGIC

2.4.2 ANALOG MODE

ANALOG mode allows analog and digital control of the unit via the ELCO connector at the rear of the unit. The front panel setpoint and RF ON key are no longer functional. RF OFF, while RF is ON, is active as usual.

To configure for analog see Figures 6 and 7.

- 1) Connect ground sense to controller ground.
- 2) Tie external interlock to system interlock.
- 3) RFON* input expects a high to low transition to turn RF ON and a low to high transition to turn RF OFF.
- 4) At the front panel program polarity and range functions as required. Setpoint and feedback must be the same polarity. For example, if a voltage probe with a negative output is used, a negative setpoint must be used.
- 5) If desired, program probe constant at the front panel.
- 6) Optional analog connections.
 - 6a) Gate enable. See pulse mode application.
 - 6b) Gate signal. See pulse mode application.
 - 6c) Incident, reflected power monitors. These analog outputs are proportional to power output. 5V = rated power for incident monitor and 5V = 10% of rated power for reflected monitor.
 - 6d) Status indicator RFENABLED*. This open collector output is normally low if RF is on (See RF ON & OK and Load & Tune functions).
- 7) Unit is now ready to operate in ANALOG control. Enter programming environment and enable analog to enter analog mode. Upon return to the status environment the operational field will indicate ANALOG.
- 8) To operate, pull RFON* input low and adjust setpoint (observing the previously programmed range) for desired power. If in voltage control mode, adjust setpoint to obtain the desired feedback level. For example, given a 200:1 probe and a desired electrode voltage of -400 volts, the setpoint should be -2 volts.

FIG 6 FULL ANALOG - DC VOLTAGE CONTROL

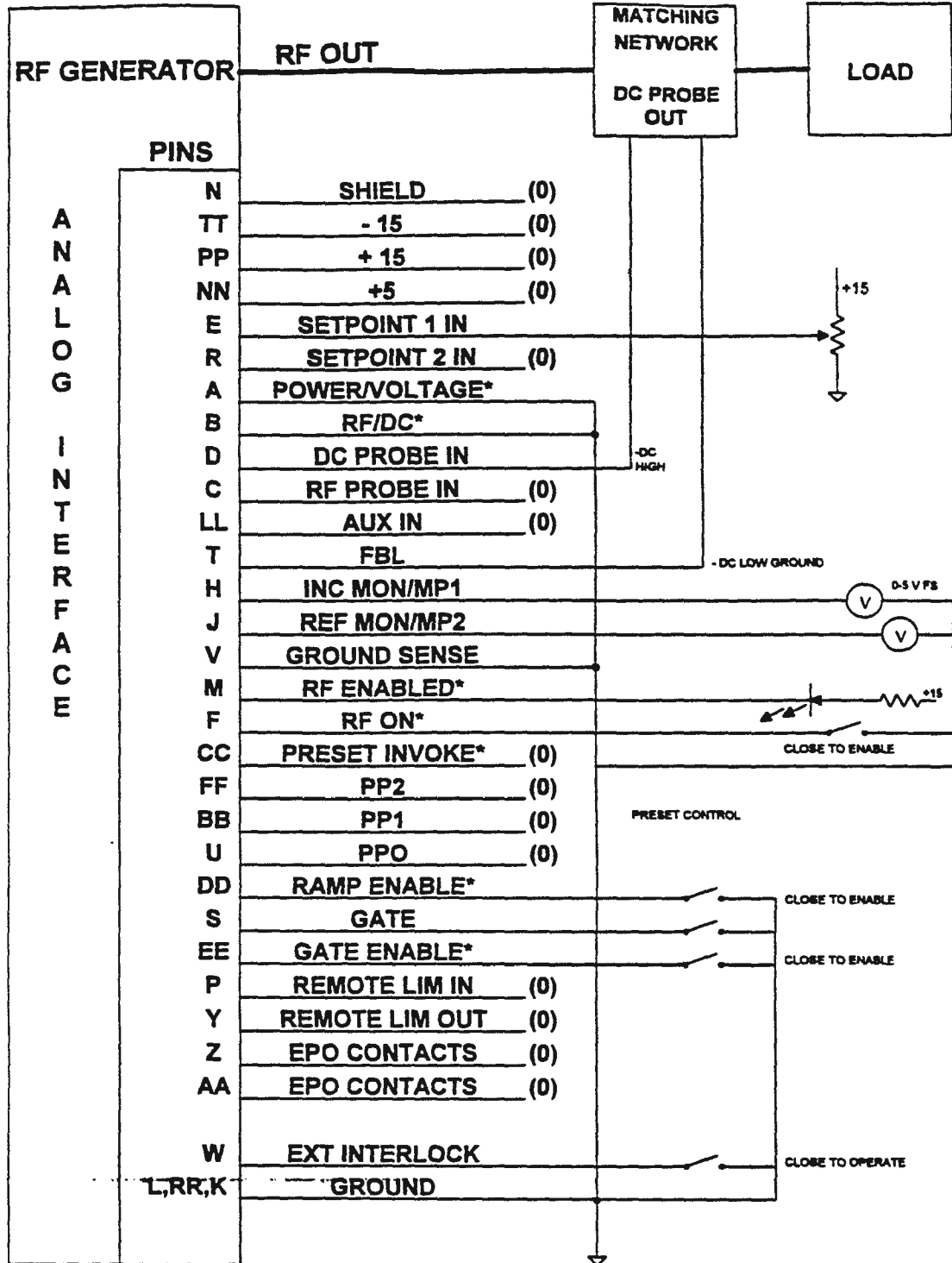

NOTES:

- (0) INDICATES OPEN TERMINAL
- * INDICATES NEGATIVE LOGIC

**FIG 7 FULL ANALOG DCV
(WITH MATCHING NETWORK PRESETS)**

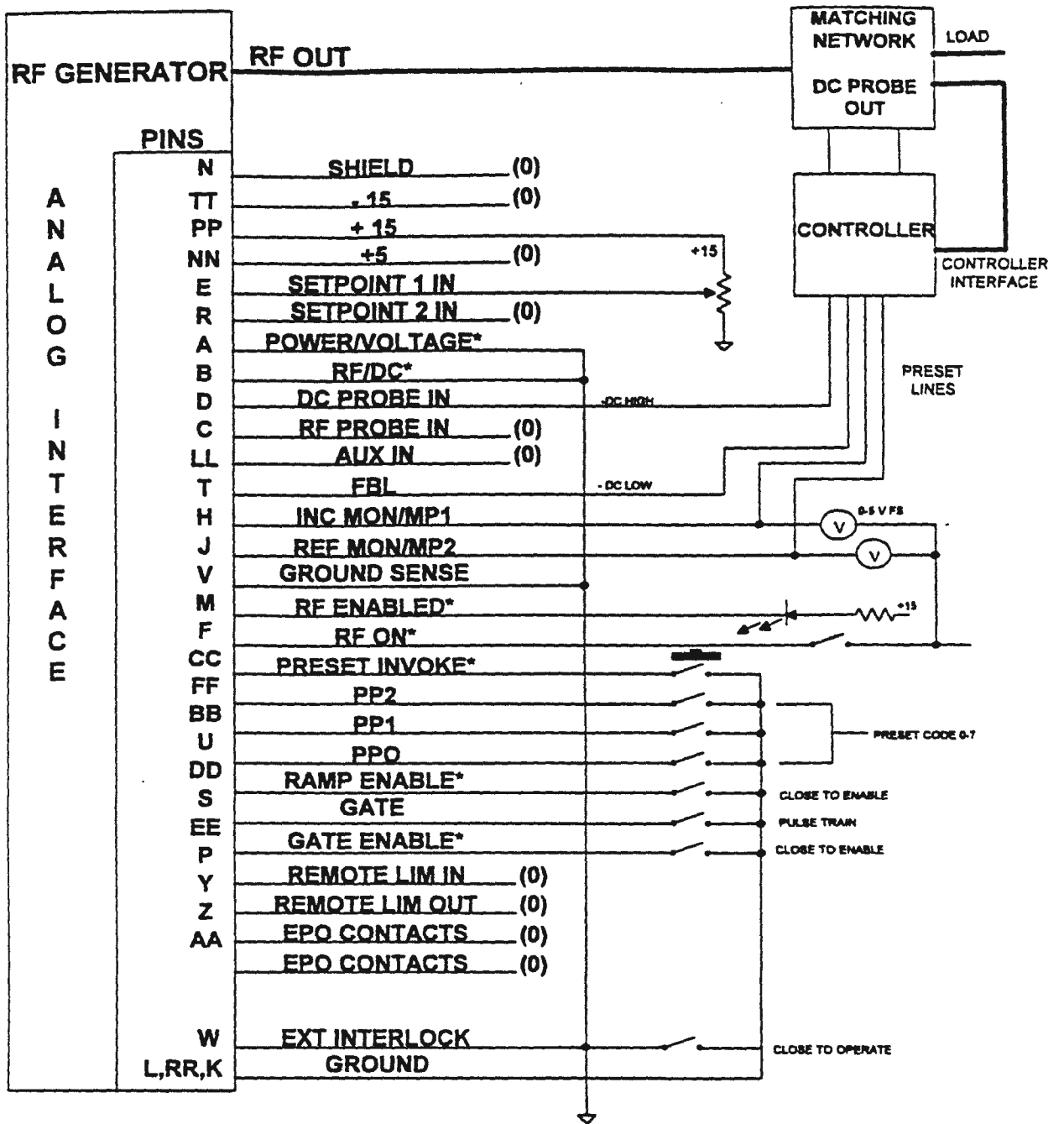

NOTES:
 (0) INDICATES OPEN TERMINAL
 * INDICATES NEGATIVE LOGIC

2.4.3 ANALOG PULSE MODE

Refer to Figure 8.

The generator can be pulsed in two different ways. It can be pulsed by using an internal CPU timer to control pulse transitions (PANEL or SERIAL) or via rear panel controls (ANALOG). In the ANALOG mode the user applies a pulse gate signal to the gate pin on the ANALOG interface. ANALOG pulsing is not available in serial or panel control.

To enable ANALOG pulse mode pull pin EE (gate enable) to ground. When RF is turned ON the power supply will expect to see transitions on the gate pin. A high to low transition on the gate pin will transfer setpoint control of the generator to setpoint # 1. A low to high transition will transfer setpoint control of the generator to setpoint # 2.

Setpoint, pulse enable and gate can be changed with RF ON. It is therefore possible to change from CW to pulse operation, modify duty cycle or setpoint power levels with RF ON.

NOTE: MINIMUM HIGH AND LOW TIMES FOR ANALOG PULSING ARE 2 MILLISECONDS WHICH IS EQUIVALENT TO 250 Hz PULSING FREQUENCY WITH A 50% DUTY CYCLE.

FIG 8 ANALOG PULSE MODE

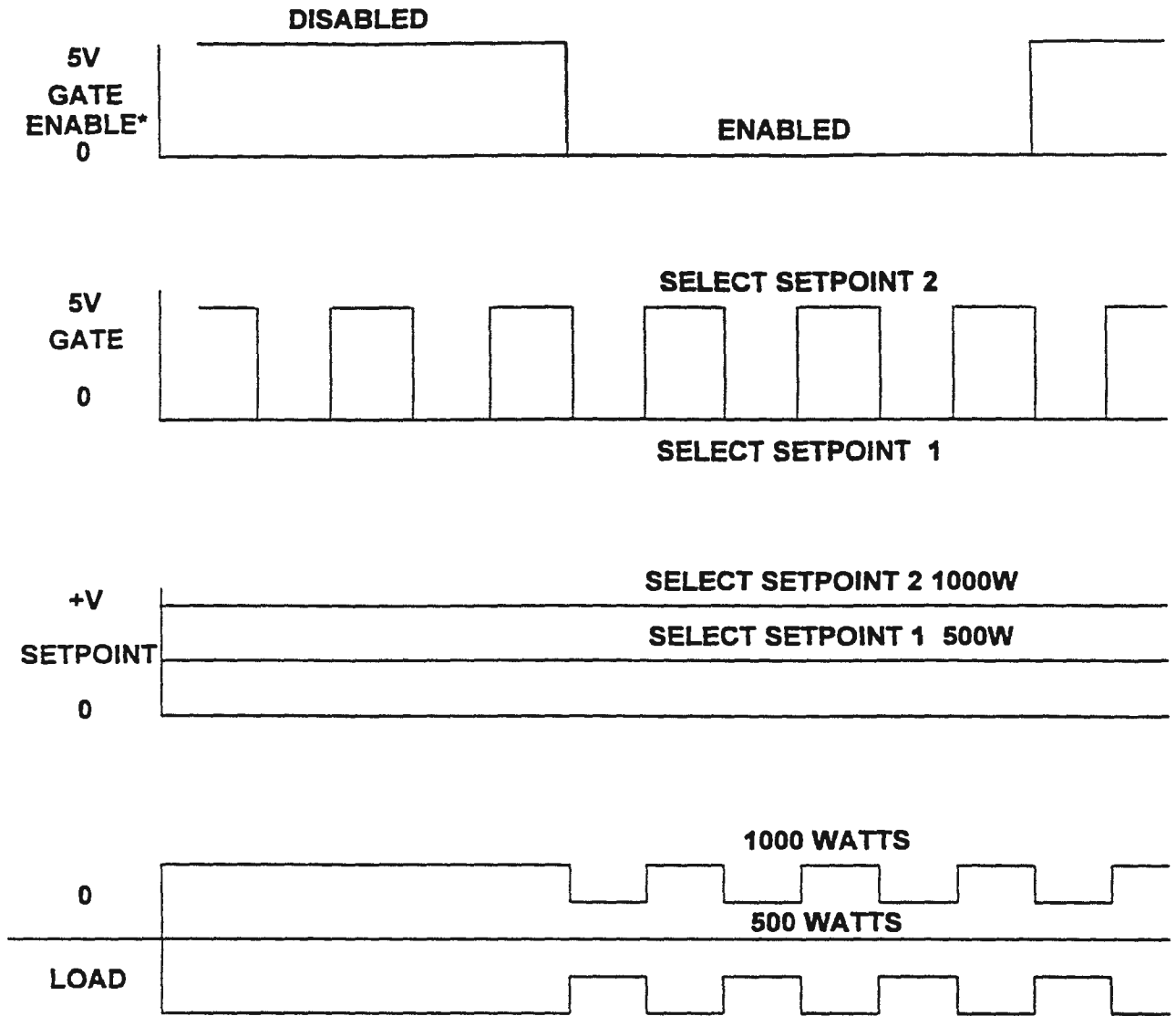

2.4.4 SERIAL CONTROL

RFPP generators may be configured to communicate serially via one of the following interfaces options: 232(EIA-232-E), 422(EIA-422-A), 485-2-wire or 485-4-wire(EIA-485). All interface options allow the user to remotely control and monitor the operation of the unit. Unless otherwise specified, the unit will be configured for shipment in the following manner:

9600	Baud
8	Data Bits*
1	Stop Bit*
No	Parity*

* Not programmable

The choice of serial interface option has been made a programmable entry. The new parameter...

Communications	485-4
	485-2
	422
	232

... may be found in the SYSTEM column of the PROGRAMMING ENVIRONMENT.

2.4.4.1 232 INTERFACE OPTION

Under the 232 interface option, the generator has two modes of communication. These are human and computer modes.

The human mode of operation prompts the user for the necessary inputs, and provides descriptive error messages and status information.

The computer mode is much more cryptic in nature. In general the commands are much shorter. Error messages are limited to a simple Nack and status information is encoded. The acknowledge signal is a carriage return and the error acknowledge is an ASCII "N" (04Eh) followed by a carriage return.

Figure 9a and 9b depict the serial interface pinouts available at the rear of the generator for either the db25 or db9 (RF5S) style of connector.

2.4.4.2 422 INTERFACE OPTION

422 interfaces are differential and as such provide a greater degree of noise immunity than 232. In addition, the 422 option may be selected for use in either single-drop or multi-drop applications. A "drop" refers to a device or peripheral capable of serial communications.

When 422 is selected as the interface option, the "number of drops (serial devices) in the system" parameter ...

Multi-Drop	Enabled
	Disabled

... may be found in the SYSTEM column of the PROGRAMMING ENVIRONMENT.

An important consideration when deciding between multi-drop interfaces (422 or 485) is that in 422 multi-drop applications the serial peripheral is a **receiver only**. If two way communications between a system controller and more than one serial device is desired, the user should select one of the available 485 options.

Single-drop (multi-drop disabled) should be selected when the power supply is the sole peripheral in the system with which the controller needs to communicate. In this case, the power supply will behave much like 232 (above). Again, human or computer mode may be selected based on the user's application.

Multi-drop (enabled) should be selected when the power supply is but one serial device in a serial communications system. Again, under 422 multi-drop, **all communications from the power supply will be suppressed because the power supplies are receivers only**. Because there are more than one serial peripheral, the controlling computer will have to be able to distinguish between them. To facilitate this, each device must be given a distinct address.

When 422 is selected, the device address parameter ...

Device Address	98
	1

... may be found in the SYSTEM column of the PROGRAMMING ENVIRONMENT.

At this point a means of handling addresses and commands called a protocol must be agreed upon. While no "standard" protocol exists, we have implemented a simple and effective method of handling multi-drop communications.

2.4.4.3 RFPP MULTI-DROP PROTOCOL

Each command issued by the controlling system to the peripherals must be preceded by an address. The address shall be a three character string as follows ...

@##

... where ## represents a 2 digit number from 01 to 98 (address 99 is reserved for global commands). **Leading zeroes are required for device addresses 1 to 9**. If a carriage return is detected during receipt of the address string, any characters received to that point will be discarded. To avoid bus contention as the address string is being parsed, **echoing of address characters (regardless of the human / computer mode setting) will be suppressed**. ...

Upon receipt of its address the peripheral will respond with the acknowledge character, upper case A (041h). In 422 multi-drop **no acknowledge will be transmitted because the peripherals are receivers only**.

Subsequent to the acknowledge, the peripheral will be ready to process and execute the command that follows. Commands to the peripherals are to be delimited by the carriage return character (0Dh). The form of the command (including 422), whether the command is echoed and the form of the response (both excluding 422) will be dependent on whether human or computer mode communications has been selected. In 422 multi-drop **no echoing of commands, command responses, reprompts or error messages will be transmitted because the peripherals are receivers only**.

Address 99 has a unique function. It serves as the global command address. When this address is placed on the bus by the controlling computer **ALL** devices will execute the command that follows. Since all the peripherals are unable to communicate at the same time (bus contention), **acknowledgment of receipt of the global address is suppressed**. In addition, **no command responses, reprompts or error messages will be transmitted during the processing of a global command**.

FIGURE 9A

DB25 PINOUTS

<u>PIN</u>	<u>SIGNAL</u>
3	232 RCV
2	232 XMIT
9	422/485-4 +RCV (485-2+RCV/XMIT)
10	422/485-4 -RCV (485-2-RCV/XMIT)
12	422/485-4 +XMIT
13	422/485-4 -XMIT
7	GROUND
1	SHIELD

FIGURE 9B

DB9 PINOUTS

<u>PIN</u>	<u>SIGNAL</u>
3	232 RCV
4	232 XMIT
5	422/485-4 +RCV (485-2+RCV/XMIT)
6	422/485-4 -RCV (485-2-RCV/XMIT)
7	422/485-4 +XMIT
8	422/485-4 -XMIT
9	GROUND

2.4.4.4 485-2-WIRE AND 485-4-WIRE OPTIONS

485-2 and 485-4 interfaces are also differential and as such provide a greater degree of noise immunity than 232. In 485-2-wire a single pair of wires is used for receive and transmit. In 485-4-wire a separate pair of wires is used for receive and transmit.

Like the 422 option, 485-2 and 485-4 may be selected for use in either single-drop or multi-drop applications. A "drop" refers to a device or peripheral capable of serial communications.

When 485-2 or 485-4 is selected as the interface option, the "number of drops (serial devices) in the system" parameter ...

Multi-Drop	Enabled
	Disabled

... may be found in the SYSTEM column of the PROGRAMMING ENVIRONMENT.

An important consideration when deciding between multi-drop interfaces (422 or 485) is that in 422 multi-drop applications the serial peripheral is a receiver only. If two way communications between a system controller and more than one serial device is desired, the user should select one of the available 485 options.

Single-drop (multi-drop disabled) should be selected when the power supply is the sole peripheral in the system with which the controller needs to communicate with serially. In this case, the power supply will behave much like 232 (above). Again, human or computer mode may be selected based on the user's application.

Multi-drop (enabled) should be selected when the power supply is but one serial device in a serial communications system. Because there are more than one serial peripheral, the controlling computer will have to be able to distinguish between them. To facilitate this, each device must be given a distinct address.

When 485-2 or 485-4 is selected, the device address parameter ...

Device Address	98
	1

... may be found in the SYSTEM column of the PROGRAMMING ENVIRONMENT.

See the preceding description on RFPP's multi-drop protocol.

2.4.4.5 422, 485-2 AND 485-4 BUS TERMINATIONS

All RFPP power supplies capable of communicating via 422 or 485 are factory configured with bus terminators. If more than two units are connected to a common bus, terminators should be removed from all but the "end" units on the bus. In RFPP generators this can be accomplished by removing jumpers JP14 and JP15 from the control board.

Figure 9a and 9b depict the serial interface pinouts available at the rear of the generator for either the db25 or db9 (RF5S) style of connector.

Figure 10a, 10b and 10c depict the 232, 485-2 wire and 485-4 wire or 422 serial interface connections between a controller and RFPP power supplies. Figures 10d and 10e depict the bus layout for multi-drop and single drop communications between a controller and 1 or more generators.

FIGURE 10A

232 CONTROLLER CONNECTIONS

CONTROLLER	GENERATOR (DB25)	
<u>TRANSMIT</u>	<u>RECEIVE</u>	PIN 3
<u>RECEIVE</u>	<u>TRANSMIT</u>	PIN 2
<u>GROUND</u>	<u>GROUND</u>	PIN 7

CONTROLLER	GENERATOR (DB9)	
<u>TRANSMIT</u>	<u>RECEIVE</u>	PIN 3
<u>RECEIVE</u>	<u>TRANSMIT</u>	PIN 4
<u>GROUND</u>	<u>GROUND</u>	PIN 9

FIGURE 10B

485 2-WIRE CONNECTIONS

CONTROLLER	GENERATOR (DB25)	
<u>+ RECEIVE / TRANSMIT</u>	<u>+ RECEIVE / TRANSMIT</u>	PIN 9
<u>- RECEIVE / TRANSMIT</u>	<u>- RECEIVE / TRANSMIT</u>	PIN 10

CONTROLLER	GENERATOR (DB9)	
<u>+ RECEIVE / TRANSMIT</u>	<u>+ RECEIVE / TRANSMIT</u>	PIN 5
<u>- RECEIVE / TRANSMIT</u>	<u>- RECEIVE / TRANSMIT</u>	PIN 6

FIGURE 10C

485 4-WIRE OR 422 CONNECTIONS

GENERATOR (DB25)

+ TRANSMIT	+ RECEIVE	PIN 9
- TRANSMIT	- RECEIVE	PIN 10
+ RECEIVE	+ TRANSMIT	PIN 12
- RECEIVE	- TRANSMIT	PIN 13

GENERATOR (DB9)

+ TRANSMIT	+ RECEIVE	PIN 5
- TRANSMIT	- RECEIVE	PIN 6
+ RECEIVE	+ TRANSMIT	PIN 7
- RECEIVE	- TRANSMIT	PIN 8

FIGURE 10D MULTI-DROP BUS LAYOUT 485 2-WIRE

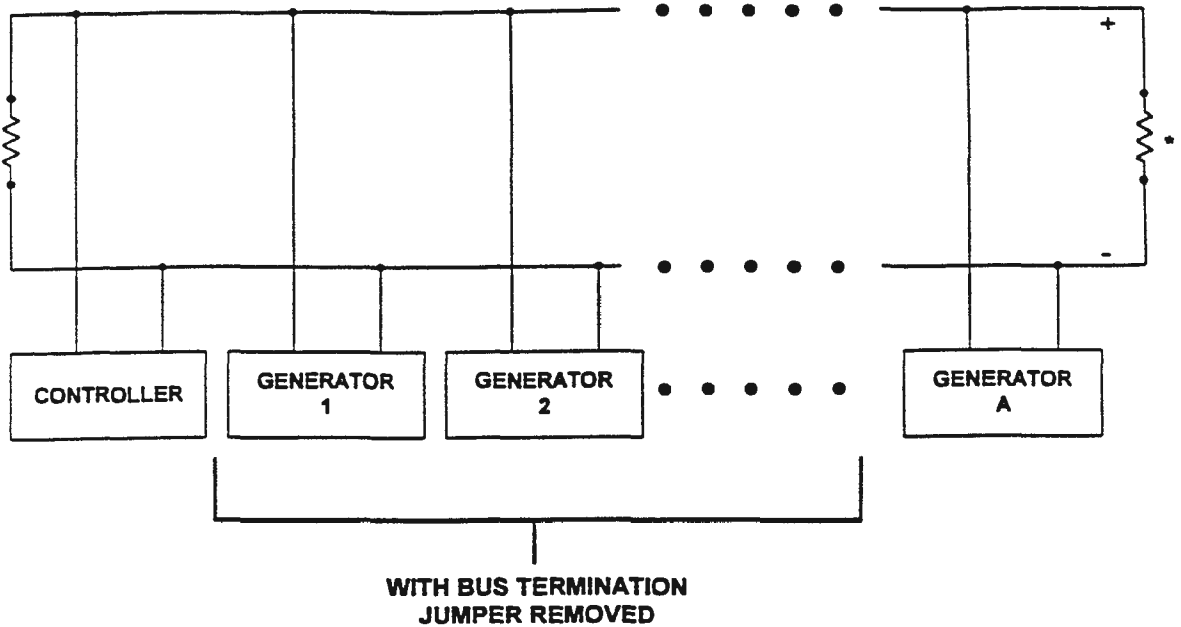

485 4-WIRE OR 422

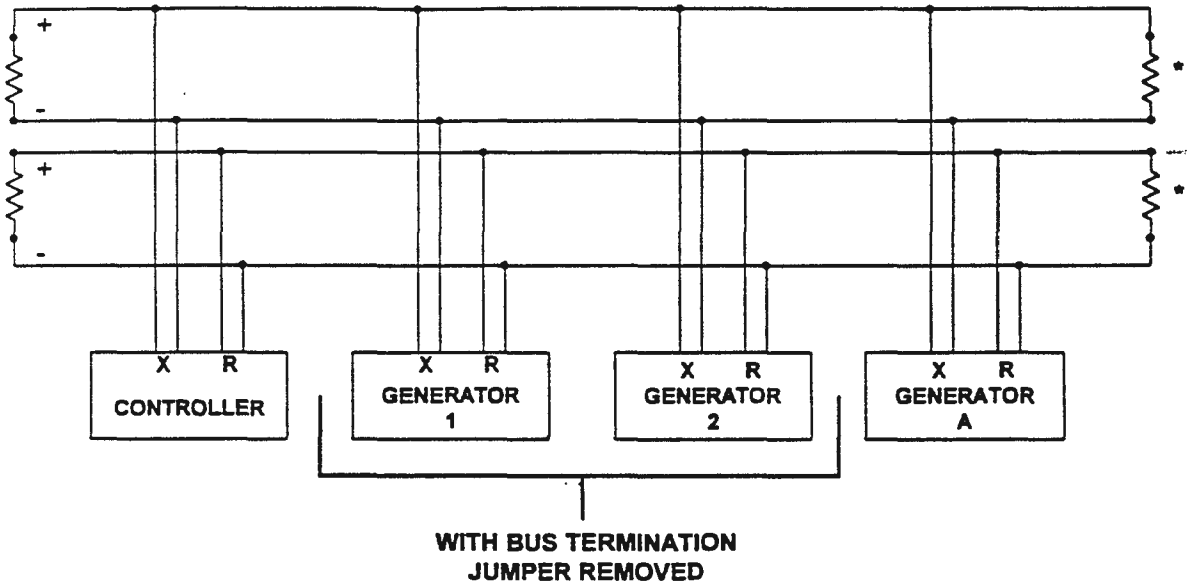

* OPTIONAL EXTERNAL BUS TERMINATION
(IF USED, REMOVE BUS TERMINATION FROM GENERATOR A)

FIGURE 10E SINGLE DROP BUS LAYOUT

485 2-WIRE

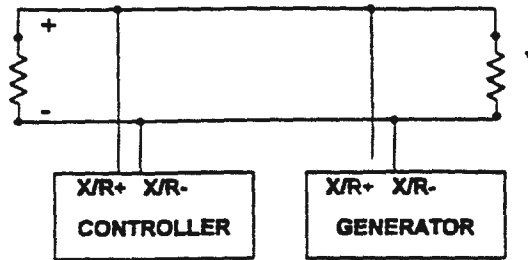

485 4-WIRE OR 422

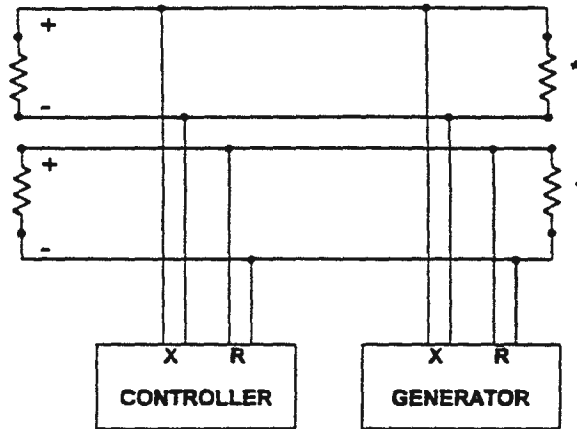

* OPTIONAL EXTERNAL BUS TERMINATION
(IF USED, REMOVE BUS TERMINATION FROM GENERATOR)

2.5 MULTI-GENERATOR OPERATION

It is possible to operate several generators into the same load if care is taken to ensure that each generator is adequately protected from high reflected power conditions. The best performance will be given by an electrode structure which is not conducive to feedthrough power between ports. To fully protect a given generator it is necessary to fold back incident power on all the other supplies when high reflected power is detected. This necessitates the utilization of the REMOTE LIMIT OUTPUT signal (on the generator that is to be protected) and the REMOTE LIMIT INPUT signal (on all the other supplies). If other than RFPP generators are used in the system, the use of external directional couplers and a method of external foldback may be required. Refer to Figures 11, 12 and 13.

NOTE: To operate in this manner the output frequencies of the generators must be synchronized (i.e. a common exciter system must be used).

2.5.1 CALIBRATION PROCEDURE FOR DUAL GENERATOR SYSTEM

Calibrate the setup as follows:

- 1) Connect the RF output port of both generators (A and B) into separate 50 Ohm loads. Also connect pin Y (Remote Limit In) of generator A to pin P (Remote Limit Out) on generator B and connect pin P (Remote Limit Out) of generator A to pin Y (Remote Limit In) on generator B.
- 2) Set the power setpoint on generator A to 50 watts and the power setpoint on generator B to approximately 5% below its reflected power limit.

RF5	35 Watts (37 Watt limit)
HF5	75 Watts (80 Watt limit)
RF10	70 Watts (75 Watt limit)
HF10	140 Watts (150 Watt limit)
RF20	140 Watts (150 Watt limit)
RF20WC	285 Watts (300 Watt limit)
RF20H	665 Watts (700 Watt limit)
RF30	430 Watts (450 Watt limit)

- 3) Remove output cable from generator "B".
- 4) Enable RF in "A" and "B". Generator "B" will then emit a remote limit output signal whose level will be just below the actual reflected limit threshold. This output will be used as the remote limit input signal on generator "A".
- 5) Adjust remote limit on generator "A" (See Fig. 13) until incident power indicated on generator "A" folds back to 0 watts.
- 6) Disable RF in "A" and "B".
- 7) Reconnect output cable from generator "B" to load.
- 8) Set the power setpoint on generators B to 50 watts and the power setpoint on generator A to approximately 5% below its reflected power limit (see above table).
- 9) Disconnect output cable from generator "A".
- 10) Enable RF in "A" and "B". Generator "A" will then emit a remote limit output signal whose level will be just below the actual reflected limit threshold. This output will be used as the remote limit input signal on generator "B".

- 11) Adjust remote limit on generator "B" (See Fig. 13) until incident power indicated on generator "B" folds back to 0 watts.
- 12) Disable RF in "A" and "B".
- 13) Reconnect output cable from generator "A" to load.
- 14) Remote limit outputs for a dual generator system are now calibrated.

2.5.2 CALIBRATION PROCEDURE FOR QUAD GENERATOR SYSTEM

Operation with three or more generators into a single load requires the use of the Remote Limit Interface box option - RLI (RFPP part # 7910490010). Calibrate the setup as follows:

- 1) Connect all remote limit inputs and outputs to the RLI as shown in Figure 12. Remove cover from RLI.
- 2) Connect the RF output port of all generators into separate 50 Ohm loads.
- 3) Set the power setpoint on all generators to approximately 5% below their respective reflected power limits.

RF5	37 Watts
RF10	75 Watts
HF10	150 Watts
RF20	150 Watts
RF20WC	300 Watts
RF20H	700 Watts
RF30	450 Watts

- 4) Remove RF output cable from generator "A".
- 5) Enable RF in generators "A", "B", "C" and "D".
- 6) Adjust channel A Gain Pot in the RLI for a 1.5 volt output.
- 7) Disable RF in all generators.
- 8) Repeat steps 3 through 6 for all remaining channels, at which point the RLI will have been adjusted.
- 9) Adjust remote limit pots on all generator control boards as per instructions in Section 2.5.1. Any open cable will then fold back forward power on the other generators.

FIGURE 11 DUAL GENERATOR CONFIGURATION

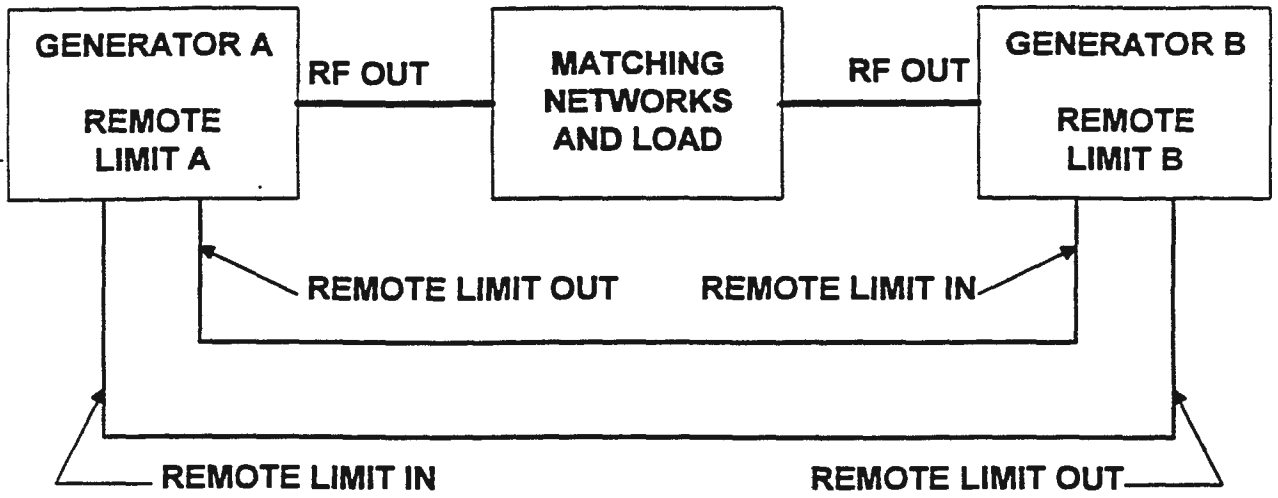

FIGURE 12 QUAD GENERATOR CONFIGURATION

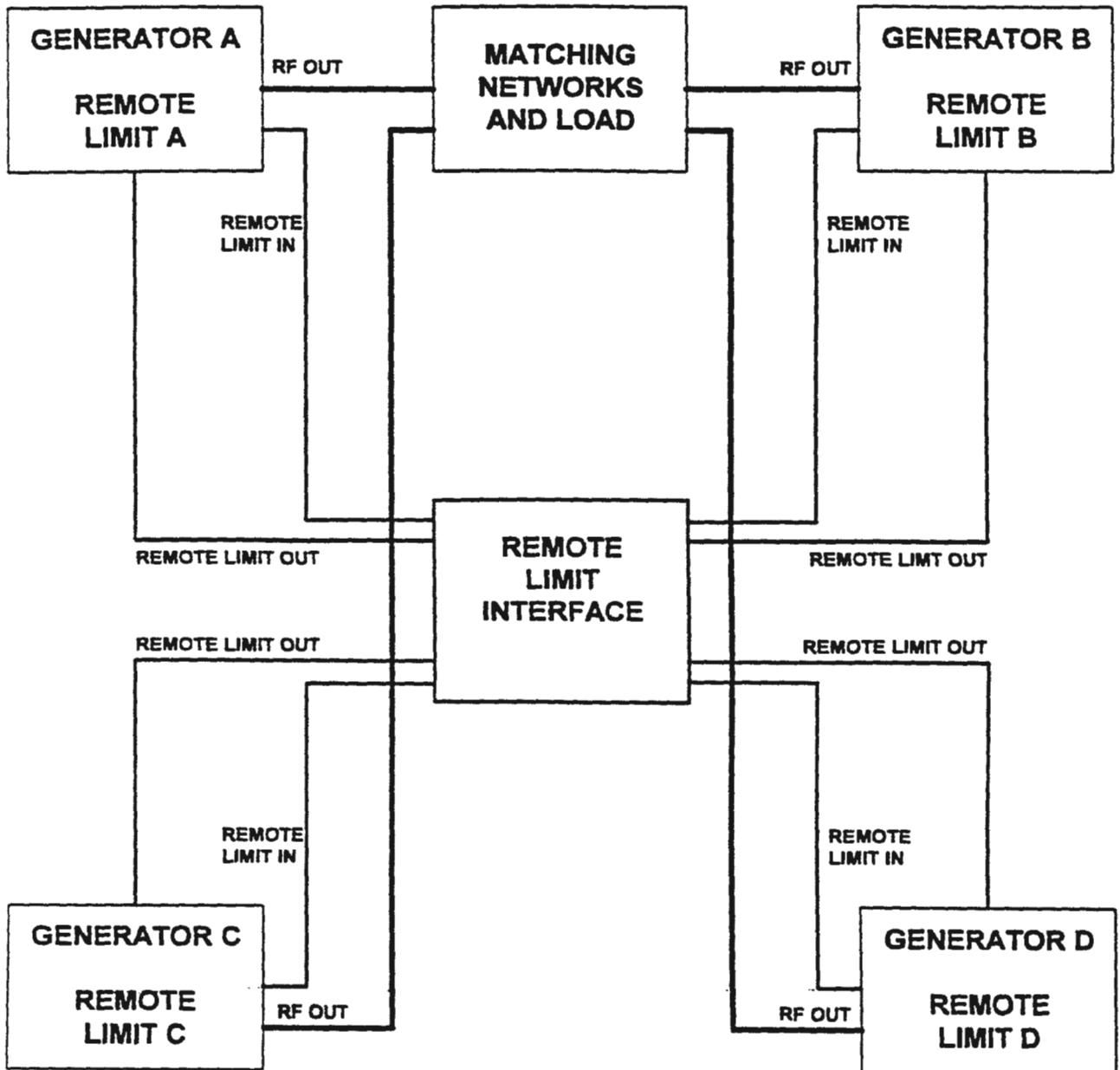
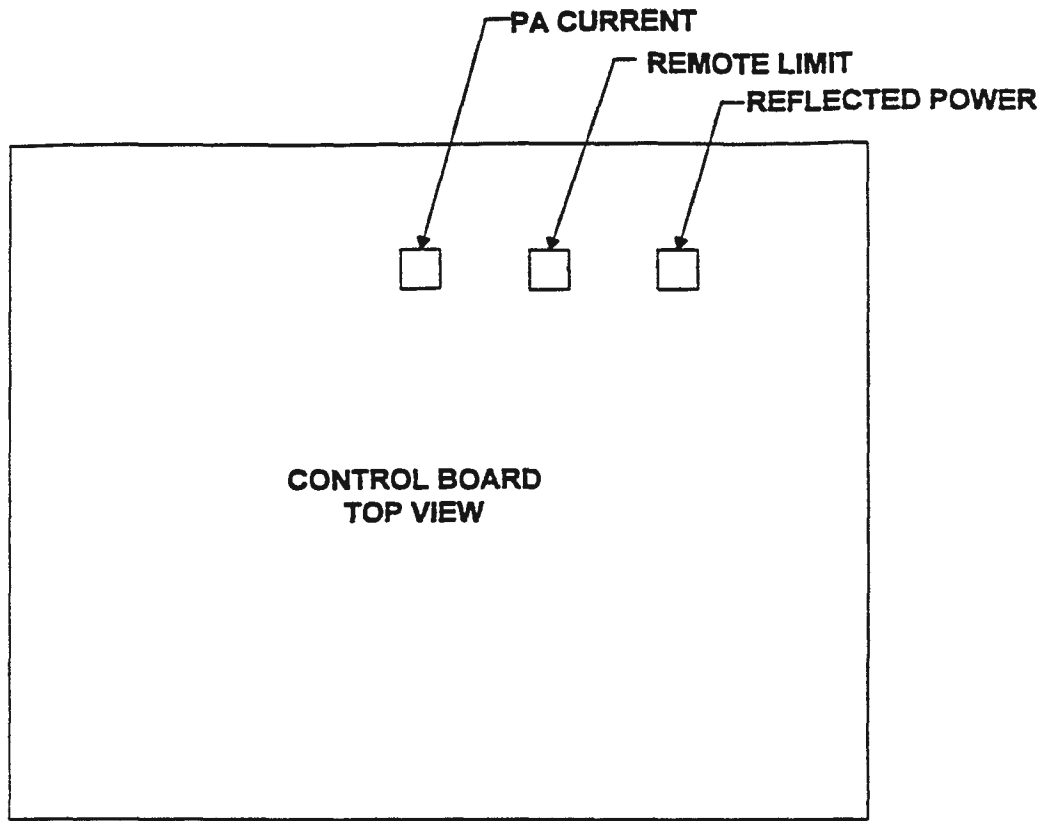
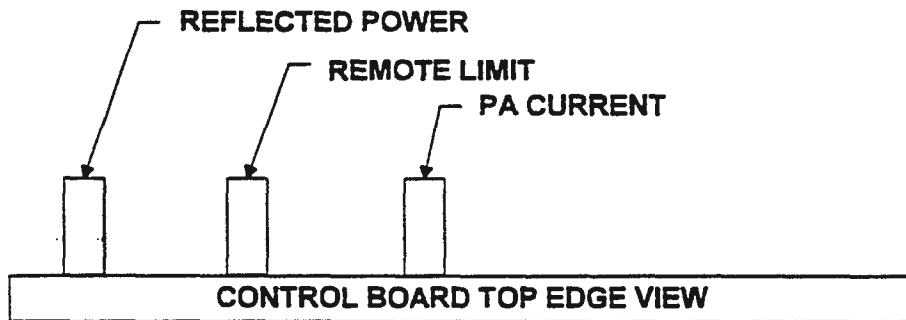

FIGURE 13 LIMIT POT ADJUSTMENT LOCATION



RF-5S



ALL OTHER RF GENERATORS

SECTION III

FRONT PANEL PROGRAMMING

3.1 STATUS ENVIRONMENT AND ADJUSTMENT BUTTONS

During standard operation of the generator, the two line front panel display might show with RF OFF ...

Top line	Set 1600W Max 1666W
Bottom line	RFP PANEL

... or into a matched load with RF ON ...

Top line	Fwd 1600W Ref 0W
Bottom line	RFP PANEL

This standard operation display is called the STATUS ENVIRONMENT. In the STATUS ENVIRONMENT, with RF OFF, the ADJUSTMENT ARROW buttons increase or decrease setpoint. With RF ON the ADJUSTMENT ARROW buttons increase or decrease forward power.

To program selected parameters from the front panel, the user must leave the STATUS ENVIRONMENT and enter what is called the PROGRAMMING ENVIRONMENT.

3.2 PROGRAMMING ENVIRONMENT AND PROGRAM BUTTON

Entrance to the PROGRAMMING ENVIRONMENT is controlled by the PROGRAM button. Once the PROGRAM button has been pressed, the display's top line changes to indicate, with RF ON, forward power (or feedback voltage) and reflected power as well as the present programming column. For example ...

500 0 Analog ... or ... 500 0 Pulsing

... or with RF OFF ...

Setpoint in watts and the present programming column. For example ...

500 Operate ... or ... 500 System

... and the display's bottom line changes to show the top entry in the present PROGRAMMING ENVIRONMENT column. Consult the PROGRAMMING ENVIRONMENT column sheet in this manual. Once in the PROGRAMMING ENVIRONMENT, the user may return to the STATUS ENVIRONMENT by pressing the PROGRAM button again. Pressing the PROGRAM button toggles the user between environments.

3.3 MOVEMENT WITHIN THE PROGRAMMING ENVIRONMENT

INTRA-COLUMN movement is controlled by the LEFT ARROW and RIGHT ARROW buttons. The LEFT ARROW button moves the user up the column until the top of the column is reached. The RIGHT ARROW moves the user down the column until the bottom of the column is reached.

INTER-COLUMN movement is controlled by the OPTIONS button. Pressing the OPTIONS button moves the user between the top entries of the 5 columns in the following order ...

... Analog --> Presets --> Pulsing --> Operate --> System --> Analog ...

3.4 FRONT PANEL PARAMETER PROGRAMMING

Parameter programming in the PROGRAMMING ENVIRONMENT is accomplished in a three step process.

- 1) Using the OPTIONS, LEFT ARROW and RIGHT ARROW buttons, move to the desired parameter.
- 2) Using the ADJUSTMENT ARROW buttons, alter the displayed parameter value.
- 3) Either move to another parameter or, using the PROGRAM button, return to the STATUS ENVIRONMENT. If the parameter that was being programmed was altered, its " new " value will be programmed and saved (subsequent power-ups).

TABLE 3
RF SERIES 10/25 PROGRAMMING ENVIRONMENT COLUMNS

ANALOG COLUMN		PRESETS COLUMN		PULSING COLUMN		OPERATE COLUMN		SYSTEM COLUMN	
Analog	Enabled	Run(ning)	Presets # 6	Proc HI Power	0000W	Max Power	0000W	Compliance	100%
	Disabled		Presets # 5		0W		0W		1%
Control	RF Power	Presets	Presets # 4	Proc Low Power	0000W	L: 00000V	T: 00000V	REF Power Alarm	000W
	AUXiliary		Presets # 3		0W				0W
Load Fwd	RF Volts	Presets	Presets # 2	Proc HI Time	10000ms	Load Preset A	5000ms	Communications	481-4
	DC Volts		Presets # 1		0ms		0ms		481-2
Polarity	Power Leveling	Pres. Clock	Presets # 0	Proc Duty Cycle	100%	Time Preset A	5000ms		422
			Enabled		1%		0ms		232
Voltage Range	Positive	Program Preset #	...	Proc Pulse	Enabled			[Device Address	98]
	Negative		6		Disabled		Load Preset D	5000ms	[
Exciter	10V	PF Control	1	Save Proc	Parameters	Time Preset D	5000ms	[Multi-Drop	Enabled]
	5V		RF Power				0ms	[Disabled]
Panel RF ON	Slave	PF Ramping	RF Power	Set HI Power	0000W	Time Preset D	5000ms	Baud Rate	38400bps
	Master		AUXiliary		0W		0ms		19200bps
Panel Setup	Enabled	PF Suspend	RF Volts	Set Low Power	0000W	Using Preset Pair	D		9600bps
	Disabled		Enabled		0W		A		4800bps
RF ON & OK	Enabled	PF Load Power Fwd	DC Volts	Set HI Time	10000ms	Load & Time	Enabled		2400bps
	Disabled		Disabled		50ms		Disabled		1200bps
RF ON & OK	Enabled	PF Interval	0000W	Set Duty Cycle	100%	Ramp Time	9:00:00		600bps
	Disabled		0000V		1%		0:00:01		300bps
RF ON & OK	Enabled	PF AutoSeq	Leveling	Set Duration	2500ms	Setup Ramp	Enabled	Serial Mode	Human
	Disabled		0:00:00		1ms		Disabled		Computer
RF ON & OK	Enabled	PF Jump to Preset	6	Set Pulse	Enabled	Probe Constant	10000	Service Code	9999
	Disabled		0		Disabled		1		
RF ON & OK	Enabled	PF Jump to Preset	6	Save Srt	Parameters	VTC	100		
	Disabled		0				1		
RF ON & OK	Enabled	PF Jump to Preset	6			PIC	100		
	Disabled		0				1		
RF ON & OK	Enabled	PF Jump to Preset	6			Voltage Scale	100		
	Disabled		0				1		
RF ON & OK	Enabled	PF Jump to Preset	6			RF ON Check	Enabled		
	Disabled		0				Disabled		
RF ON & OK	Enabled	PF Jump to Preset	6			Watts Default	0000W		
	Disabled		0				0W		
RF ON & OK	Enabled	PF Jump to Preset	6			Volts Default	0000V		
	Disabled		0				0V		

3.5 STATUS ENVIRONMENT MNEMONICS

3.5.1 CONTROL

The first field (3 characters) on the bottom line of the VFD represents the selected mode of control for the generator.

"RFP" indicates that the unit is regulating on forward power. The internal directional coupler is the source of feedback for the control loop.

"DCV", "RFV" and "AUX" indicate which of the three voltage control input channels available through the rear panel ELCO connector of the power supply have been selected as the feedback source.

3.5.2 OPERATIONAL MODE

The next field (6 characters) on the bottom line of the VFD is reserved for the operational mode of the generator.

"PANEL" indicates that the generator is in the front panel mode. The front panel controls (setpoint adjustment, RF ON and RF OFF) are functional.

"ANALOG" indicates that the generator is in the analog mode. This means that the source for setpoint, RF ON and RF OFF commands is the rear panel analog control interface. Front panel controls, with the exception of RF OFF, are not active.

"SERIAL" indicates that the unit is under serial control. All functions are programmable over the serial link.

NOTE: When setpoint is being adjusted from the front panel both the control and operational mode mnemonics will be replaced with the display of the setpoint as it is changing, and for two seconds after it has stopped changing.

NOTE: If either the RF ON CLOCK or the PRESET CLOCK is enabled, the RF ON TIMER will be displayed to the right of the OPERATIONAL MODE field.

3.5.3 EXT CEX

The next field (3 characters) on the bottom line of the VFD is reserved for the display of the selected exciter source of the generator.

"CEX" indicates that the unit has been programmed to accept an external excitation source. It is intended for applications requiring synchronous operation of two or more generators. A blank field indicates that the source of excitation for the generator is the internal exciter.

3.5.4 PULSING/RAMPING/PROGRAMMABLE PRESETS

The next field (5 characters) on the bottom line of the VFD indicates whether process or analog pulsing is enabled OR ramping from RF ON is enabled OR a programmable preset from 1 to 6 (or preset 0) is enabled. These three functions have been made mutually exclusive (i.e. pulsing may not be enabled if a programmable preset is enabled).

"PULSE" indicates that pulsing is enabled. "RAMP" indicates that ramping (from RF ON) is enabled. "PST-#" (where # is a preset from 0 to 6) indicates that a programmable preset or preset 0 is enabled. A blank field indicates that none of the three aforementioned functions are enabled.

NOTE: If either the RF ON CLOCK or PRESET CLOCK are enabled, both the EXT CEX and PULSE/RAMP/PST-# mnemonics will be replaced by the display of the appropriate timer.

3.6 ALARM AND LIMIT CONDITION MNEMONICS

When in the STATUS ENVIRONMENT and an alarm or limit condition is detected, the bottom line of the VFD will alternate between a static STATUS ENVIRONMENT line and a blinking indication of the alarm or limit detected. Alarms and limits are indicated at the VFD via mnemonic fields separated by spaces based upon whether or not RF is ON. The alarms and limit conditions are listed as they appear on the bottom line of the display. A blank field indicates that the corresponding alarm is not present.

NOTE: When in the PROGRAMMING ENVIRONMENT, alarm and limit conditions are indicated by a blinking "Alarm" message that will alternate with the static column indicator in the upper right corner of the VFD.

3.6.1 RF OFF ALARM AND LIMIT MNEMONICS

3.6.1.1 COVER INTERLOCK ALARM (4 SPACES)

"CVR" indicates that a cover (internal) interlock condition exists. RF will not turn on under cover interlock condition.

3.6.1.2 EXTERNAL INTERLOCK ALARM (4 SPACES)

"EXT" indicates that an external interlock condition exists. This is typically used as the system interlock. RF will not turn on under external interlock alarm condition.

3.6.1.3 PA UNBALANCE / FAN / TEMP ALARM (4 SPACES)

"PAU" indicates that one or more of the 50 Amp fuses on the interconnect board has failed indicating that the corresponding PA has probably had one or more FETs fail.

"FAN" indicates that a fan failure exists. The alarm is the result of a detected drop in fan rotation speed. RF will not turn on under the air flow alarm condition.

"TMP" indicates that the generator has seen, and has shut RF off, due to an excess temperature condition detected on one or more PA heat sinks. RF will not be allowed back on until the heat sink temperature has been reduced.

3.6.1.4 HIGH OR LOW LINE VOLTAGE ALARM (3 SPACES)

"HLV" indicates that the line exceeds the nominal primary power tap setting by more than 7%. "LLV" indicates that the line is below the nominal primary power tap setting by more than 7%. RF will not turn on under a high line condition.

3.6.2 RF ON ALARM AND LIMIT MNEMONICS

3.6.2.1 MAX POWER LIMIT (5 SPACES)

"MAXP" indicates that the requested forward power exceeds the programmed maximum power limit. This means that the power being produced is above the maximum power threshold. A maximum power limit may also occur under reflected or PA current limit conditions.

3.6.2.2 REF LIMIT (6 SPACES)

"REFP" indicates that the generator has detected reflected power in excess of the programmable reflected power alarm threshold. See the SYSTEM column description for "REF Power Alarm" in this section.

3.6.2.3 PA CURRENT LIMIT (4 SPACES)

"PAC" indicates that the maximum current level, as programmed at the factory, has been reached in the power amplifier section.

3.6.2.4 POWER DISSIPATION / RF OUTPUT ALARM (5 SPACES)

"XPDIS" indicates that the FETs are dissipating power in excess of the programmable limit and that the generator has folded forward power back to reduce the dissipated power at each FET.

"RFOUT" indicates a forward power compliance error. If the ratio of reflected to incident power exceeds the programmed ratio, a compliance error exists. Factory set for 5%. See the SYSTEM column description for "Compliance" in this section.

3.7 PROGRAMMING ENVIRONMENT COLUMNS

3.7.1 ANALOG COLUMN

Analog	Enabled Disabled	Use the ADJUSTMENT ARROWS to display the desired state of this programmable feature. Enabling Analog will permit entrance into the ANALOG generator control state. Disabling Analog will return the generator to the PANEL control state. Changing the state of this programmable feature with RF ON is NOT PERMITTED .
Control	RF Power AUXiliary RF Volts DC Volts	Use the ADJUSTMENT ARROWS to display the desired state of this programmable feature. RF Power selects power control, while AUXiliary , RF Volts and DC Volts select the auxiliary voltage control, RF voltage control and DC voltage control terminals, respectively, as the source of feedback for voltage control. Changing control from the front panel AFTER analog is enabled is not permitted.
Load Fwd	Power Leveling	Use the ADJUSTMENT ARROWS to display the desired state of this programmable feature. Selecting LOAD POWER LEVELING will cause the supply to regulate on net output power (Forward - Reflected). Selecting FWD POWER LEVELING will cause the generator to regulate on forward or incident power.
Polarity	Positive Negative	Use the ADJUSTMENT ARROWS to display the desired state of this programmable feature. Positive selects positive polarity over the chosen voltage range (below) for the setpoint and feedback channels. Negative selects negative polarity over the voltage range for the setpoint and feedback channels.
Voltage Range	10V 5V	Use the ADJUSTMENT ARROWS to display the desired state of this programmable feature. 10V selects the 0 to \pm (from polarity above) 10 volt range for the setpoint and feedback channels. 5V selects the 0 to \pm (polarity) 5 volt range for the setpoint and feedback channels.
Exciter	Slave Master	Use the ADJUSTMENT ARROWS to display the desired state of this programmable feature. Master indicates that the source of excitation for the generator comes from the internal oscillator. Slave indicates that the excitation source is coming from an external oscillator to the external excitation terminal at the rear of the generator. Changing the state of this programmable feature with RF ON is NOT PERMITTED .
Panel RF ON	Enabled Disabled	Use the ADJUSTMENT ARROWS to display the desired state of this programmable feature. When Panel RF ON is Enabled and the generator is operating in the ANALOG state, the RF ON button on the front panel (and not the RFON* analog interface pin) controls the turning ON and OFF of RF .

NOTE: The front panel **RF ON/OFF** button is **ALWAYS ACTIVE WITH RF ON**.

Panel Setpt	Enabled Disabled	Use the ADJUSTMENT ARROWS to display the desired state of this programmable feature. When Panel Setpt is Enabled and the generator is operating in the ANALOG state, the ADJUSTMENT ARROWS on the front panel control setpoint.
RF ON & OK	Enabled Disabled	Use the ADJUSTMENT ARROWS to display the desired state of this programmable feature. When RF ON & OK is enabled, the RFENABLED* analog interface pin will be low if and only if RF is ON AND all limit and alarm conditions indicate satisfactory operation. When RF ON & OK is disabled, the RFENABLED* pin will be low unconditionally when RF is ON.

NOTE: The RF ON & OK feature may not be Enabled when Matching Network Presets Enabled/Disabled feature (Load & Tune) is Enabled.

3.7.2 PRESETS COLUMN

For additional information on PRESETS consult Section IV in this manual.

Run(ning) Preset #	6 5 4 3 2 1 0	When accessed, this menu entry will display the presently executing preset or text indicating that presets are disabled. Use the ADJUSTMENT ARROWS to select the desired preset to execute or to disable presets. After selecting the preset to execute (or presets disabled), press the PROGRAM button to "invoke" your selection.
Presets	Disabled	
Pres. Clock	Enabled Disabled	Use the ADJUSTMENT ARROWS to display the desired state of this programmable feature. When enabled, the preset clock function will cause the display of the CEX and PULSE/RAMP/PRESET # mnemonic fields in the STATUS ENVIRONMENT to be replaced with the display of a preset timer. This timer will display the length of time that a programmable preset (1-6) has been running. It is reset to 0 each time a new programmable (1-6) preset is invoked. Additionally, the timer is "frozen" if RF was turned OFF while a programmable preset was executing.
Program Preset #	6 1	Use the ADJUSTMENT ARROWS to display the programmable preset number to program/view. Once this number has been selected, programmable preset parameters will all pertain to this preset number. (i.e. If it is desired to program/view a given parameter, the Program Preset number for that parameter must be previously selected.)
P# Control	RF Power AUXiliary RF Volts DC Volts	Use the ADJUSTMENT ARROWS to display the desired state of this programmable feature. RF Power selects power control for preset P# while AUXiliary, RF Volts and DC Volts select the auxiliary voltage control, RF voltage control and DC voltage control terminals, respectively, as the source of feedback for voltage control for preset P#.
NOTE:	Changing the control mode for preset P#, automatically zeroes the setpoint parameter and disables the ramping function parameter for preset P#.	
P# Ramping	Enabled Disabled	Use the ADJUSTMENT ARROWS to enable or disable the ramping function for P# under power control. If Ramping is enabled, a ramp (up or down) in power <i>from</i> the existing setpoint <i>to</i> P# Setpoint <i>over</i> P# Interval will occur. If P# Ramping is disabled, the generator will run <i>at</i> P# Setpoint <i>for</i> P# Interval.
NOTE:	If the mode of control for P# is one of the voltage control options, this entry will not be displayed.	
P# Setpoint	####W ####V	Use the ADJUSTMENT ARROWS to display the desired setpoint level in volts or watts for preset P#.
P# Load Fwd	Power Leveling	Use the ADJUSTMENT ARROWS to display the desired means of output power regulation for the preset being programmed. See Analog Column.

P# Interval	##:##:## 00:00:00	Use the ADJUSTMENT ARROWS to select the time interval for P#. If P# Ramping is enabled, the programmable interval for this preset is from 0 seconds to 9 hours and RF output will be ramped to P# Setpoint over P# Interval. If P# Ramping is disabled or operating under voltage control, the programmable interval for this preset is from 0 seconds to 18 hours, 12 minutes, 15 seconds and the generator will run at P# Setpoint for P# Interval.
P# AutoSeq	Enabled Disabled	Use the ADJUSTMENT ARROWS to enable or disable the automatic sequencing function for P#. If AutoSeq is enabled for P#, at the conclusion of the execution of preset P# (P# Interval timeout) the programmed Jump to Preset P# will automatically begin executing. If AutoSeq is disabled for P#, upon timeout of P# Interval, preset # 0 will automatically begin executing.
P# Jump to Preset	6 0	Use the ADJUSTMENT ARROWS to select the preset that will execute upon termination (via timeout) of the presently executing preset provided the AutoSeq function for this preset is enabled.

NOTE: If AutoSeq is disabled for P#, this entry will not be displayed.

3.7.3 PULSING COLUMN

Proc Hi Power	####W 0W	Use the ADJUSTMENT ARROWS to display the desired process pulse high power level. This level, set between 0 and MAX POWER, is the high power level for process (continuous pulse train) pulsing of the generator (Refer to Fig. 14). Process pulsing may be enabled while in either serial or panel control ONLY. In analog control refer to the discourse on analog pulsing in this manual.
Proc Low Power	####W 0W	Use the ADJUSTMENT ARROWS to display the desired process pulse low power level. This level, set between 0 and MAX POWER, is the low power level for process (continuous pulse train) pulsing of the generator (Refer to Fig. 14). Process pulsing may be enabled while in either serial or panel control ONLY. In analog control refer to the discourse on analog pulsing in this manual.
Proc Hi Time	10000ms 2ms	Use the ADJUSTMENT ARROWS to display the desired process pulse high time. This time interval (in multiples of 2 milliseconds) is the time spent at the high power level during process pulsing of the generator (Refer to Fig. 14). When a modification of this parameter is attempted, Process Pulsing is automatically disabled until the process pulse parameters (as a group) are checked for validity. This verification is only performed at the ...

Proc Pulse Enabled

menu entry. Process pulsing may be enabled while in either serial or panel control ONLY. In analog control refer to the discourse on analog pulsing in this manual.

Proc Duty Cycle	100% 1%	Use the ADJUSTMENT ARROWS to display the desired process pulse duty cycle. This duty cycle is defined as the ratio of process pulse high time to pulse period. When a modification of this parameter is attempted, Process Pulsing is automatically disabled until the process pulse parameters (as a group) are checked for validity. This verification is only performed at the ...
-----------------	------------	--

Proc Pulse Enabled

menu entry. Process pulsing may be enabled while in either serial or panel control ONLY. In analog control refer to the discourse on analog pulsing in this manual.

Proc Pulse

Enabled
Disabled

Use the **ADJUSTMENT ARROWS** to display the desired state of this programmable feature. When attempting to enable process pulsing, the process pulse parameters are checked (as a group) to ensure that they are valid.

i.e. Hi Time of 2 ms with Duty Cycle of 90 % would result in an invalid Low Time of less than 2 ms.

If the group of parameters is invalid, an appropriate error message is displayed on the bottom line of the VFD. When enabled with RF ON, Proc Pulse will cause the generation of a continuous RF power pulse train whose parameters are described above (Refer to Fig. 14). Process pulsing may be enabled while in either serial or panel control ONLY. In analog control refer to the manual's discourse on analog pulsing.

Save Proc Parameters

Pressing the **PROGRAM** button at this menu entry will cause the present programmed values for process pulsing to be stored into non-volatile memory, thus becoming the "new" default values. Pressing the **PROGRAM** button at this menu entry **DOES NOT** return the operator to the **STATUS ENVIRONMENT** but rather displays a function performed "Finished" message.

3.7.3.1 A Word On Programming Start Pulse Parameters

Start pulsing parameters also (as a group) must satisfy the following formula ...

$$\{(HIGH\ POWER * DUTY) + LOW\ POWER (100 - DUTY)\} <$$

RF5	—	37 WATTS
HF5	—	75 WATTS
RF10	—	75 WATTS
HF10	—	150 WATTS
RF20	—	150 WATTS
RF20WC	—	300 WATTS
RF20H	—	700 WATTS
RF30	—	450 WATTS

As such, when any modification of the first five programmable start pulse parameters is attempted, Start Pulsing is automatically disabled until the new group validity is verified. This verification is only performed at the ...

Start Pulse Enabled

menu entry. If the validity check fails while attempting to enable (either UP ARROW button) Start Pulsing, an "Invalid Start Params" message will be displayed for a few seconds, followed by the display returning to the original entry. If the parameters satisfy the equation, Start Pulsing will be enabled.

FIGURE 14 PROCESS PULSE TIMING

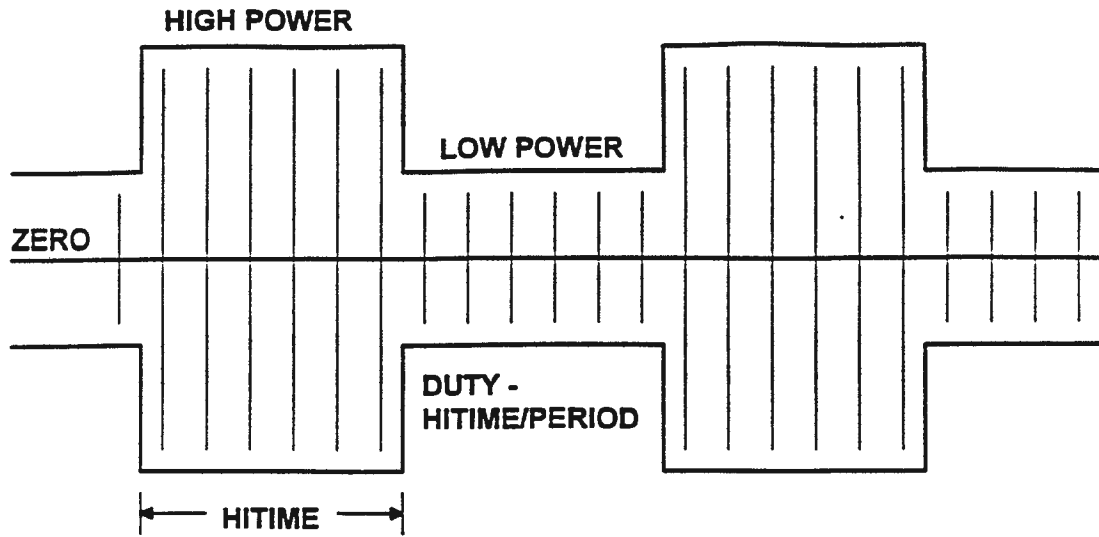
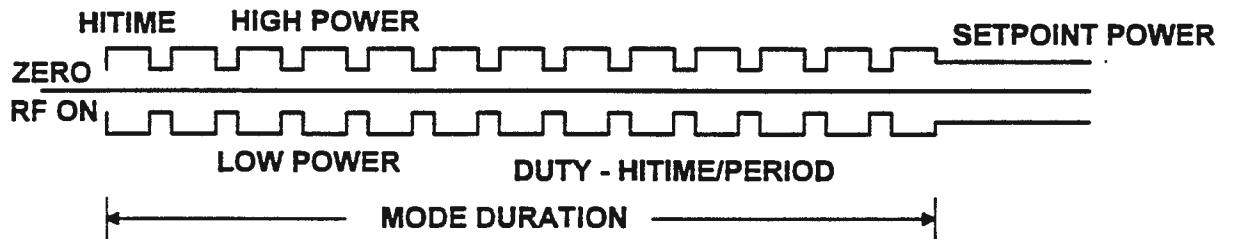

FIGURE 15 START PULSE TIMING



Strt Hi Power	####W 0W	Use the ADJUSTMENT ARROWS to display the desired start pulse high power level. This level, set between 0 and MAX POWER, is the high power level for a short burst of RF power at RF ON used for ignition purposes (See Fig. 15).
Strt Low Power	####W 0W	Use the ADJUSTMENT ARROWS to display the desired start pulse low power level. This level, set between 0 and MAX POWER, is the low power level for a short burst of RF power at RF ON used for ignition purposes (See Fig. 15).
Strt Hi Time	10000µs 1µs	Use the ADJUSTMENT ARROWS to display the desired start pulse high time. This time interval (in microseconds) is the time spent at the high power level during start pulsing of the generator (See Fig. 15).
Strt Duty Cycle	100% 1%	Use the ADJUSTMENT ARROWS to display the desired start pulse duty cycle. This duty cycle is defined as the ratio of start pulse high time to pulse period (See Fig. 15).
Start Duration	2500ms 1ms	Use the ADJUSTMENT ARROWS to display the desired start pulse duration. This duration (in milliseconds) is defined as the period of time that the supply will pulse before going to setpoint (See Fig. 15).

NOTE: Attempted modification of these five parameters will result in the unconditional disabling of Start Pulsing.

Strt Pulse	Enabled Disabled	Use the ADJUSTMENT ARROWS to display the desired state of this programmable feature. Pressing either UP ADJUSTMENT ARROW button at this menu entry will cause the present programmed values for start pulsing to be checked and, if valid, the start pulse feature will be enabled for subsequent RF ON requests. If invalid, an appropriate message will be displayed.
-------------------	-----------------------------	---

Save Start Parameters Pressing the PROGRAM button at this menu entry will cause the present programmed values for start pulsing to be stored into non-volatile memory, thus becoming the "new " default values. Pressing the PROGRAM button at this menu entry DOES NOT return the operator to the STATUS ENVIRONMENT but rather displays a function performed "Finished" message.

3.7.4 OPERATE COLUMN

Max Power **####W** Use the ADJUSTMENT ARROWS to display the desired maximum output power level. This power level may be set within the allowable range of 0 WATTS to ...
 0W

RF5	555 Watts	RF20	2222 Watts
HF5	555 Watts	RF20H	2222 Watts
RF10	1111 Watts	RF30	3333 Watts.
HF10	1111 Watts		

L:####mv **T:####mv** this menu entry displays the positions of the Tune and Load capacitors of the associated matching network.

When operating in RF Power or DC Voltage control modes and using the **RFPP Preset Cable With DC Probe (Part # 32-07318-010)**, the capacitor positions are available on pins C (TUNE) and LL (LOAD) of the analog interface ELCO connector at the rear of the generator. For other modes of control contact the factory.

NOTE: Additional cabling or switches may be required to implement this feature. Consult the factory.

Load Preset A **5000mv** Use the ADJUSTMENT ARROWS to display the desired matching network preset pair A load level with 2500 mv representing the midpoint of the capacitor adjustment. (See Load & Tune below)
 0mv

Tune Preset A **5000mv** Use the ADJUSTMENT ARROWS to display the desired matching network preset pair A tune level with 2500 mv representing the midpoint of the capacitor adjustment. (See Load & Tune below)
 0mv

Load Preset B **5000mv** Use the ADJUSTMENT ARROWS to display the desired matching network preset pair B load level with 2500 mv representing the midpoint of the capacitor adjustment. (See Load & Tune below)
 0mv

Tune Preset B **5000mv** Use the ADJUSTMENT ARROWS to display the desired matching network preset pair B tune level with 2500 mv representing the midpoint of the capacitor adjustment. (See Load & Tune below)
 0mv

Load Preset C **5000mv** Use the ADJUSTMENT ARROWS to display the desired matching network preset pair C load level with 2500 mv representing the midpoint of the capacitor adjustment. (See Load & Tune below)
 0mv

Tune Preset C **5000mv** Use the ADJUSTMENT ARROWS to display the desired matching network preset pair C tune level with 2500 mv representing the midpoint of the capacitor adjustment. (See Load & Tune below)
 0mv

Load Preset D **5000mv** Use the ADJUSTMENT ARROWS to display the desired matching network preset pair D load level with 2500 mv representing the midpoint of the capacitor adjustment. (See Load & Tune below)
 0mv

Tune Preset D	5000mv 0mv	Use the ADJUSTMENT ARROWS to display the desired matching network preset pair D tune level with 2500 mv representing the midpoint of the capacitor adjustment. (See Load & Tune below)
Using Preset Pair	D A	Use the ADJUSTMENT ARROWS to select which of the above Preset Pair voltages (A to D) will be written to the monitor outputs to preset the Load and Tune capacitor positions when RF is OFF AND the Load & Tune feature (below) is enabled.
Load & Tune	Enabled Disabled	Use the ADJUSTMENT ARROWS to display the desired state of this programmable feature. When enabled, Load & Tune places the generator in matching network control mode. The monitor outputs are redefined during the RF OFF period to supply control voltages for the PS2A controller. In addition, the RFENABLED* output polarity is inverted and used to place the controller in remote when RF is disabled. Thus, when RF is ON, the matching network is in automatic and the preset terminals are ignored. When RF is turned OFF, the controller goes to remote and uses the preset terminals to position the tune and load capacitors.
NOTE:	The RF ON & OK feature (Analog Column) may not be invoked when matching network presets are enabled.	
Ramp Time	9:00:00 0:00:01	Use the ADJUSTMENT ARROWS to display the desired ramp up time interval. When Setpt Ramp (below) is enabled, this interval is the length of time that it will take to ramp up to setpoint at RF ON.
Setpt Ramp	Enabled Disabled	Use the ADJUSTMENT ARROWS to display the desired state of this programmable feature. When enabled, this feature will cause a uniform ramping (up) of power to setpoint at RF ON.
Probe Constant	10000 1	Use the ADJUSTMENT ARROWS to display the desired Probe Constant value. This value is a scaling factor that allows the display of the requested (RF OFF) or actual (RF ON) probe voltage when operating in voltage control. The value chosen for Probe Constant is the attenuation factor of the probe.
VIC	100 1	Use the ADJUSTMENT ARROWS to display the desired Voltage Integration Constant value. Increasing this value from 1 slows the response of the generator when in voltage control.
PIC	100 1	Use the ADJUSTMENT ARROWS to display the desired Power Integration Constant value. Increasing this value from 1 slows the response of the generator when in power control.
Voltage Scale	100 1	Use the ADJUSTMENT ARROWS to display the desired Voltage Scale value. This value is a scaling factor used to accommodate alternate full scale setpoint/feedback signals. The Voltage Scale parameter should be the INTEGER UPPER BOUND of the voltage probe being used (i.e. 2.2 volt probe --- Voltage Scale = 3).

RF ON Clock	Enabled Disabled	Use the ADJUSTMENT ARROWS to display the desired state of this programmable feature. The RF ON Clock , if enabled, will cause the length of time RF has been ON (in hrs:mins:secs format) to be displayed on the bottom line of the VFD in the STATUS ENVIRONMENT . The RF ON Clock is reset to 0 only when RF is turned OFF. Additionally, this running timer is maintained in memory even if the display of the RF ON Clock is disabled.
Watts Default	####W 0W	Use the ADJUSTMENT ARROWS to display the default (AC ON) front panel power control setpoint value. This wattage setpoint will be the default power control setpoint on subsequent power-ups of the supply. Programming a default setpoint results in the removal of one step (setting setpoint) in a repetitive process.
Volts Default	####V 0V	Use the ADJUSTMENT ARROWS to display the desired default front panel voltage control setpoint level. This voltage setpoint will be the default voltage control setpoint on subsequent power-ups of the supply. Programming a default setpoint results in the removal of one step (setting setpoint) in a repetitive process.

3.7.5 SYSTEM COLUMN

Compliance	100% 1%	Use the ADJUSTMENT ARROWS to display the desired compliance alarm generation level in percent. The blinking "RFOUT" mnemonic alarm will be displayed in the event that the ratio of reflected power to incident power exceeds this programmable parameter.																
REF Power Alarm	###W 1W	Use the ADJUSTMENT ARROWS to display the desired reflected power alarm generation level within the allowable range of 1 WATT to ...																
		<table border="0"> <tr><td>RF5</td><td>37 WATTS</td></tr> <tr><td>HF5</td><td>75 WATTS</td></tr> <tr><td>RF10</td><td>75 WATTS</td></tr> <tr><td>HF10</td><td>150 WATTS</td></tr> <tr><td>RF20</td><td>150 WATTS</td></tr> <tr><td>RF20WC</td><td>300 WATTS</td></tr> <tr><td>RF20H</td><td>700 WATTS</td></tr> <tr><td>RF30</td><td>600 WATTS</td></tr> </table>	RF5	37 WATTS	HF5	75 WATTS	RF10	75 WATTS	HF10	150 WATTS	RF20	150 WATTS	RF20WC	300 WATTS	RF20H	700 WATTS	RF30	600 WATTS
RF5	37 WATTS																	
HF5	75 WATTS																	
RF10	75 WATTS																	
HF10	150 WATTS																	
RF20	150 WATTS																	
RF20WC	300 WATTS																	
RF20H	700 WATTS																	
RF30	600 WATTS																	

This blinking " REFP " mnemonic alarm will be displayed in the event that reflected power exceeds this programmable parameter.

NOTE: This is not a method to set the reflected power limit. That limit is factory set in hardware and as such **MAY NOT BE MODIFIED**.

Communications	485-4 485-2 422 232	Use the ADJUSTMENT ARROWS to select the desired means of serial communications with the power supply. See Section 2.4.4 or consult RFPP for more information on serial programming.
Device Address	98 1	Use the ADJUSTMENT ARROWS to select the desired device address for the generator. In a multi-drop configuration, this address or the ATTENTION ALL (99) address MUST precede any command transmitted to this power supply. If not, the command will be ignored by the generator. With Multi-Drop (below) Disabled, the address dependent protocol is suspended. See Section 2.4.4 or consult RFPP for more information on serial programming.

NOTE: This column entry will not be displayed if the 232 communications option has been selected.

Multi-Drop	Enabled Disabled	Use the ADJUSTMENT ARROWS to display the desired state of this programmable parameter. With Multi-Drop Enabled, commands received by the generator must be preceded by either the correct Device Address (above) or the ATTENTION ALL (99) address. If not, the command will be ignored by the generator. With Multi-Drop Disabled, the address dependent protocol is suspended. See Section 2.4.4 or consult RFPP for more information on serial programming.
-------------------	-----------------------------------	---

NOTE: This column entry will not be displayed if the 232 communications option has been selected.

Baud Rate	38400bps 19200bps 9600bps 4800bps 2400bps 1200bps 600bps 300bps 150bps	Use the ADJUSTMENT ARROWS to display the desired serial communication baud rate. See Section 2.4.4 or consult RFPP for more information on serial programming.
Serial Mode	Human Computer	Use the ADJUSTMENT ARROWS to display the desired serial communication mode. HUMAN mode is generally more descriptive while COMPUTER mode is much more cryptic. See Section 2.4.4 or consult RFPP for more information on serial programming.
Service Code	????	Use the ADJUSTMENT ARROWS to display the appropriate service code and then press the PROGRAM button. If the code is correct, entrance to the SERVICE ENVIRONMENT will be allowed.

SECTION IV
PROGRAMMABLE PRESETS

4.1 INTRODUCTION

The PROGRAMMABLE PRESETS feature allows the end user to program up to 6 separate presets that may be executed either individually or as part of a programmed recipe. Presets are programmed at the front panel or serially. Preset control is possible from the front panel, the rear panel or across the serial interface.

Please refer to the FRONT PANEL PROGRAMMING and PROGRAMMING ENVIRONMENT COLUMNS documentation during this discourse.

4.2 PRESET PARAMETERS

There exist 6 programmable presets (1 - 6) as well as two non-programmable presets (0 and 7).

Preset 7 is PRESETS DISABLED. Standard generator operation.

Preset 0 is an executable preset which ALWAYS has a 0 setpoint (watts or volts).

Associated with each of the programmable presets (except where noted) are the following parameters ...

(1)	CONTROL MODE	RF Power AUXiliary RF Volts DC Volts
(2)	RAMPING (Power Control Only)	Enable Disable
(3)	SETPOINT	Watts Volts
(4)	LEVELING	Forward Power Load Power
(5)	INTERVAL	0:00:00 to 9:00:00 (Ramping On) 0:00:00 to 18:12:15 (Ramping Off)
(6)	AUTOSEQUENCE	Enable Disable
(6a)	JUMP TO PRESET	Next preset to execute number.

FIGURE 16 PRESET TIMING

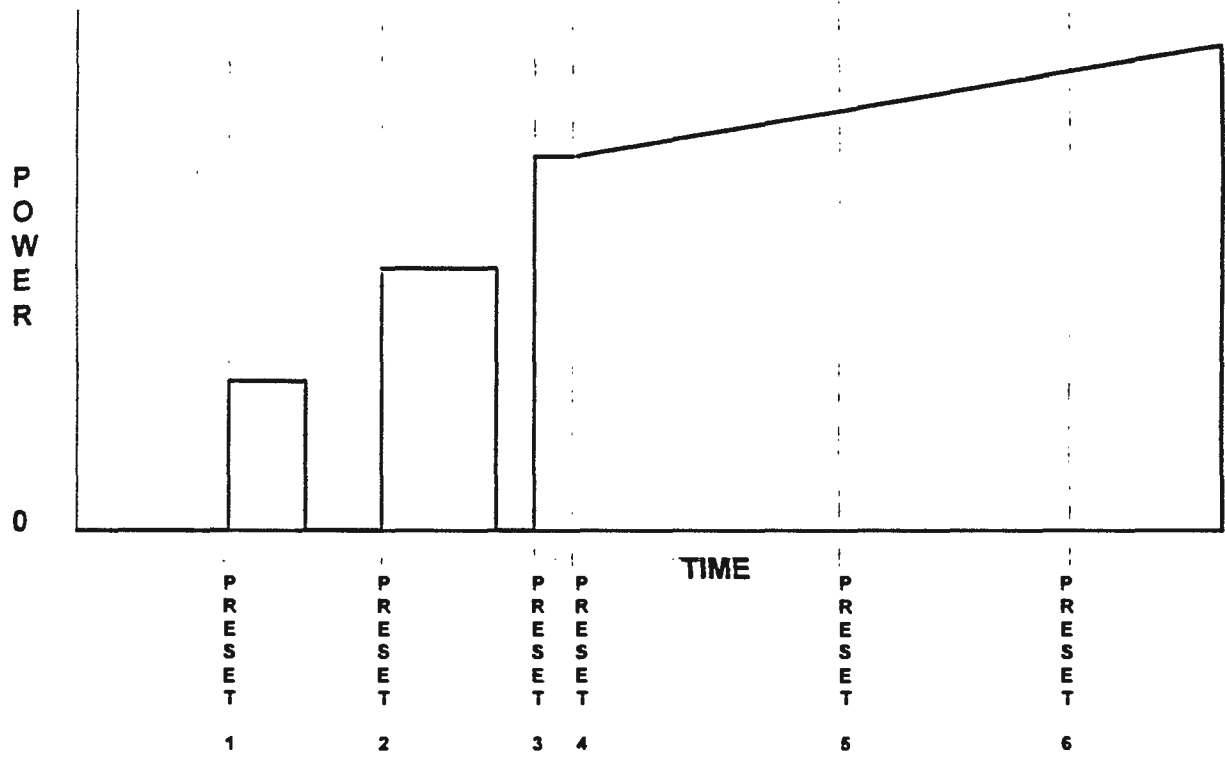
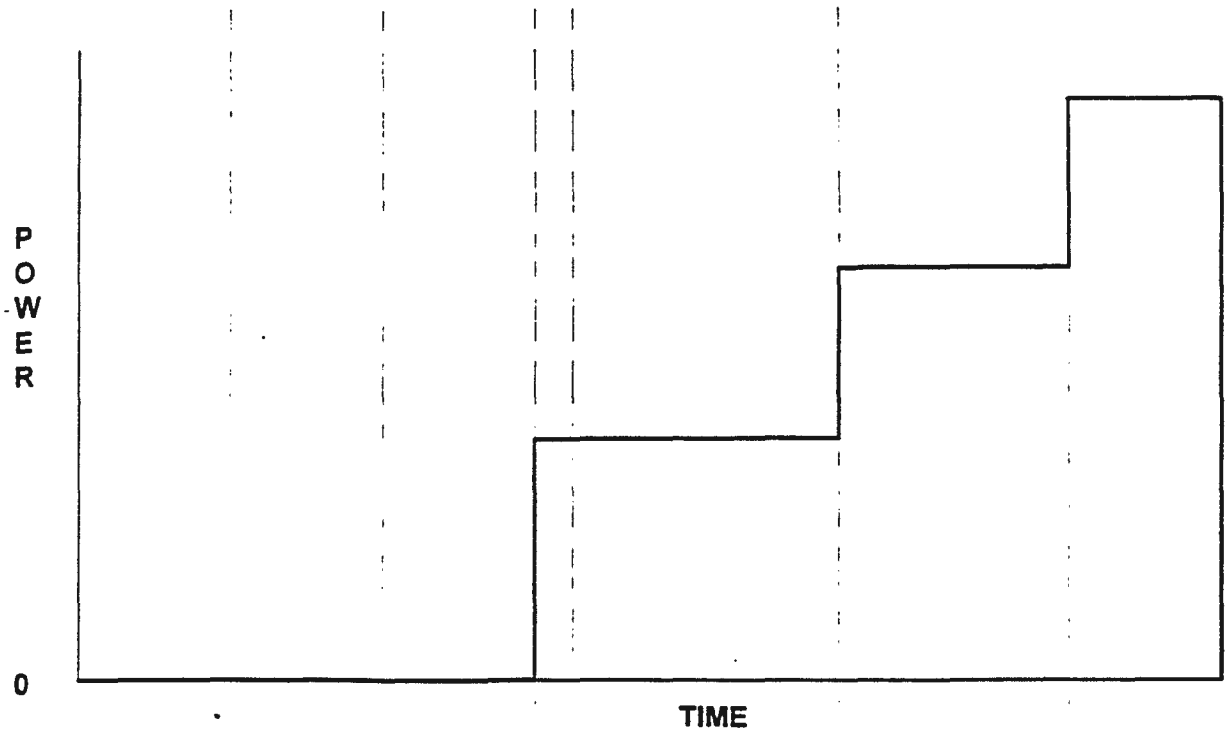

4.3 PRESET OPERATION

4.3.1 INDIVIDUAL PRESETS

Consider the bottom example of Figure 16, PRESET TIMING. For the purpose of this example the generator will have RF enabled and preset # 1 will have been programmed for RF Power control, 200 watts, a 1 minute time interval, ramping disabled and auto sequencing disabled.

NOTE: For an individual preset to be executed, its AUTO SEQUENCING function must be DISABLED.

When preset # 1 is enabled, the generator will run at its programmed power level (200 watts) for its programmed time interval (1 minute). When the preset's time interval has elapsed, preset # 0 WILL begin execution and the power level WILL drop to 0 watts. When the programmed INTERVAL for an individual preset has expired the generator will ALWAYS run preset # 0 (0 setpoint).

4.3.2 SEQUENTIAL PRESETS

For a running preset to automatically begin executing another preset (including re-executing itself) upon expiration of its time interval, its AUTO SEQUENCING function must be ENABLED and the "preset to jump to" parameter for the executing preset must be programmed.

Consider the top example of Figure 16, PRESET TIMING. For the purpose of this example preset # 5 will have been programmed for RF Power control, 200 watts, a 1 minute time interval, ramping disabled and auto sequencing ENABLED. Preset # 6 will have been programmed for RF Power control, 400 watts, a 1 minute time interval, ramping disabled, and auto sequencing disabled.

NOTE: Presets execution does not have to be sequential and is portrayed in this manner solely for convenience.

Assume that the generator is running preset # 5 at its programmed power level (200 watts) for its programmed time interval (1 minute). Since auto sequencing is ENABLED, when the time interval for preset # 5 has elapsed, preset # 6 will AUTOMATICALLY begin executing under RF Power control, at the new setpoint of 400 watts, for 1 minute with ramping disabled. Since auto sequencing for preset # 6 is disabled, when its 1 minute time interval has elapsed, preset # 0 will begin execution and the power level will drop to 0 watts.

4.3.3 PRESETS AND MULTI-GENERATOR SYSTEMS

Once again, refer to Figure 16, PRESET TIMING, for this example with the two generators having the following programmed presets ...

TOP GENERATOR

P#	Control	Leveling	Setpt	Interval	Ramp	Auto	Jump To
1	DC Volts	N/A	0V	00:02:00	OFF	OFF	N/A
2	DC Volts	N/A	0V	00:04:00	OFF	OFF	N/A
3	DC Volts	N/A	200V	00:00:02	OFF	ON	4
4	DC Volts	N/A	200V	00:10:00	OFF	ON	5
5	DC Volts	N/A	400V	00:10:00	OFF	ON	6
6	DC Volts	N/A	600V	00:10:00	OFF	OFF	0

BOTTOM GENERATOR

P#	Control	Leveling	Setpt	Interval	Ramp	Auto	Jump To
1	RF Power	Fwd	100W	00:02:00	OFF	OFF	N/A
2	RF Power	Fwd	150W	00:04:00	OFF	OFF	N/A
3	RF Power	Fwd	200W	00:00:02	OFF	ON	4
4	RF Power	Fwd	300W	00:10:00	ON	ON	5
5	RF Power	Fwd	400W	00:10:00	ON	ON	6
6	RF Power	Fwd	500W	00:10:00	ON	OFF	0

Additionally, for the purpose of this example, both generators will be operating under control of THE SAME analog system. The system, using a rudimentary signal switch box with 4 digital lines going to each of the two generators, can now control a complete process requiring multiple generators WITHOUT HAVING TO MAINTAIN EITHER SETPOINT OR TIMING CONTROL OF THE PROCESS.

The controlling analog system would begin the process with both generators executing preset # 0. This is accomplished by tying analog pins FF, BB, and U to GND and then forcing a transition on analog pin CC from 5V to GND. For more information on analog preset selection/enabling consult the EXECUTING PRESETS section of this discourse.

At the desired time (with RF enabled on both supplies) the analog system would "switch" to select and then enable preset # 1 on both generators. The TOP generator would run at 0 volts for 2 minutes while the BOTTOM generator would run at 100 watts for the same time interval. With the timeout of preset # 1, BOTH generators (the programmed interval is identical) would immediately begin running preset # 0 since neither generator has the auto sequencing function enabled for preset # 1.

Preset # 2, albeit with different power levels and time intervals, would function in the same manner. Once enabled, both generators would run preset # 2 until timing out at which point (same interval) both generators would run preset # 0 (auto sequencing disabled in both).

When ready, the controlling analog system would select and enable preset # 3 on both generators. The TOP generator would then begin running at 200V while the BOTTOM generator would commence running at 200 watts. BOTH generators would run at their respective levels for 2 seconds. After timing out, both generators would AUTOMATICALLY begin running their respective preset # 4 because both have their AUTO SEQUENCE FUNCTIONS ENABLED and JUMP TO PRESET set at 4.

At this point the analog system may let the remainder of the process run without being REQUIRED to control it. Since presets # 3, # 4, and # 5 ALL have their AUTO SEQUENCE FUNCTIONS ENABLED and both supplies have the identical JUMP TO PRESET selections, upon timing out they will AUTOMATICALLY switch to begin running the next selected preset.

Presets # 4, # 5 and # 6 on the BOTTOM generator together perform a "linear" ramp from 200 to 500 watts over an interval (total time) of 30 minutes. Each of the three presets ramp FROM THE EXISTING POWER LEVEL (UPON ENABLING OF THE PRESET) TO ITS PRESET SETPOINT.

While the analog system is not REQUIRED to "control" presets that are auto sequencing, it may at ANY TIME select and enable an alternate preset or disable presets entirely in order to wrest control away from the sequencing presets. Finally, turning RF OFF on a generator while a preset is running, WILL ALWAYS force the generator to run preset # 0.

4.4 PROGRAMMING PRESETS

4.4.1 PANEL PROGRAMMING OF PRESETS

Presets are easily programmed from the front panel and may be selected and/or enabled from the front panel, over the analog interface or serially.

Preset programming is possible provided that neither a programmable preset nor preset # 0 is running. If one of these presets is running, the parameters for an individual preset may be VIEWED BUT NOT ALTERED.

Provided that presets are disabled, use the PROGRAM and OPTION buttons on the front panel to move to the top of the PRESETS column. Then, using the RIGHT ARROW button, move down the column until the entry ...

Program Preset # n

... is displayed on the bottom line of the Vacuum Fluorescent Display (VFD). At this point use the ADJUSTMENT ARROWS to select the preset number to be programmed.

Press the RIGHT ARROW button to move down the column to the entry ...

Pn Control ?????????

... where, using the ADJUSTMENT ARROWS, the mode of control for preset n may be selected.

NOTE: Whenever the mode of control for a preset being programmed is ALTERED, the SETPOINT for that preset is UNCONDITIONALLY CHANGED to 0 and RAMPING for that preset is UNCONDITIONALLY DISABLED.

If the mode of control for this preset had been set to RF Power, pressing the RIGHT ARROW button at this point will move the user down the column to the entry ...

Pn Ramping ????????

... where, using the ADJUSTMENT ARROWS, the ramping function for preset n may be enabled or disabled.

NOTE: If the control mode for this preset HAD NOT been set to RF Power, the P# Ramping entry will be skipped making the next programmable entry P# Setpoint.

Press the RIGHT ARROW button to move down the column to the entry ...

Pn Setpoint #####c

... where, using the ADJUSTMENT ARROWS, the desired setpoint for preset n may be selected. The character c will be a W if under power control and a V if under voltage control. Additionally, the setpoint value WILL BE 0 if the control mode for this preset had been altered.

Press the RIGHT ARROW button to move down the column to the entry ...

Pn cccc Pwr Leveling

... where, using the ADJUSTMENT ARROWS, the desired means of RF power leveling for preset n may be selected. Under Fwd Pwr Leveling, the software control loop maintains *forward* power at the setpoint irrespective of reflected power provided no alarm or limit conditions exist. Under Load Pwr Leveling, the software control loop maintains *delivered* power (Incident - Reflected) at the setpoint level, again provided no alarms or limit conditions exist.

Press the RIGHT ARROW button to move down the column to the entry ...

Pn Interval ##:##:##

... where, using the ADJUSTMENT ARROWS, the desired interval for preset n may be selected. If ramping is enabled, the MAXIMUM ramp interval will be 9:00:00 hours. If ramping is disabled (or under voltage control), the MAXIMUM run interval is 18 hours 12 minutes and 15 seconds.

Press the RIGHT ARROW button to move down the column to the entry ...

Pn AutoSeq ????????

... where, using the ADJUSTMENT ARROWS, the automatic sequencing function for preset n may be enabled or disabled. If the automatic sequencing function is disabled, this entry becomes the last programmable parameter for this preset. However, if the automatic sequencing function is enabled, pressing the RIGHT ARROW button will move the user down the column to the entry ...

Pn Jump to Preset #

... where, using the ADJUSTMENT ARROWS, the desired preset to automatically sequence (jump) to for preset n may be selected.

4.4.2 SERIAL PROGRAMMING OF PRESETS

PRESETS may also be programmed over the serial interface. Consult the factory for descriptions of the available serial commands for programming presets.

With the addition of these serial commands it is possible to run complex process sequences involving a far greater variety of individual preset configurations with only 2 programmable presets. This is accomplished by serially programming an inactive preset, A, while an active preset, B, (which will jump to A upon completion) is executing.

4.5 EXECUTING PRESETS

PRESETS only execute with RF ON. While the setpoint may be zero watts or 0 volts for a given preset, for the preset's time interval to run and expire, RF must be ON.

NOTE: To enable a programmable preset or preset # 0, both the PROCESS PULSING and SETPT RAMPING functions (see PULSING and OPERATE columns of PROGRAMMING ENVIRONMENT COLUMN sheet) must be disabled.

4.5.1 PANEL

Enter the PROGRAMMING ENVIRONMENT and use the OPTION button to move to the top of the PRESETS column. On the bottom line of the VFD will be displayed either ...

Run(ning) Preset # n (if a preset is executing)

PRESETS Disabled (if presets are disabled).

Use the ADJUSTMENT ARROWS to select the desired preset to be executed or to disable presets. Press the PROGRAM button to ENABLE the selection.

4.5.2 ANALOG

When under ANALOG control configure analog pins FF , BB and U to select the desired preset as follows: [Reference Figs 17 & 18 for Connection (s) to Generator (s)]

FF	BB	U	Selects
L	L	L	Preset # 0
L	L	H	Preset # 1
L	H	L	Preset # 2
L	H	H	Preset # 3
H	L	L	Preset # 4
H	L	H	Preset # 5
H	H	L	Preset # 6
H	H	H	PRESETS Disabled

H = +5V or open pin L = Ground or low logic level

Then force a TRANSITION from 5V to GND on pin CC of the analog interface. This TRANSITION causes the selected preset (pins FF, BB and U above) to be ENABLED.

FIGURE 17 DUAL GENERATOR PRESET CONNECTION

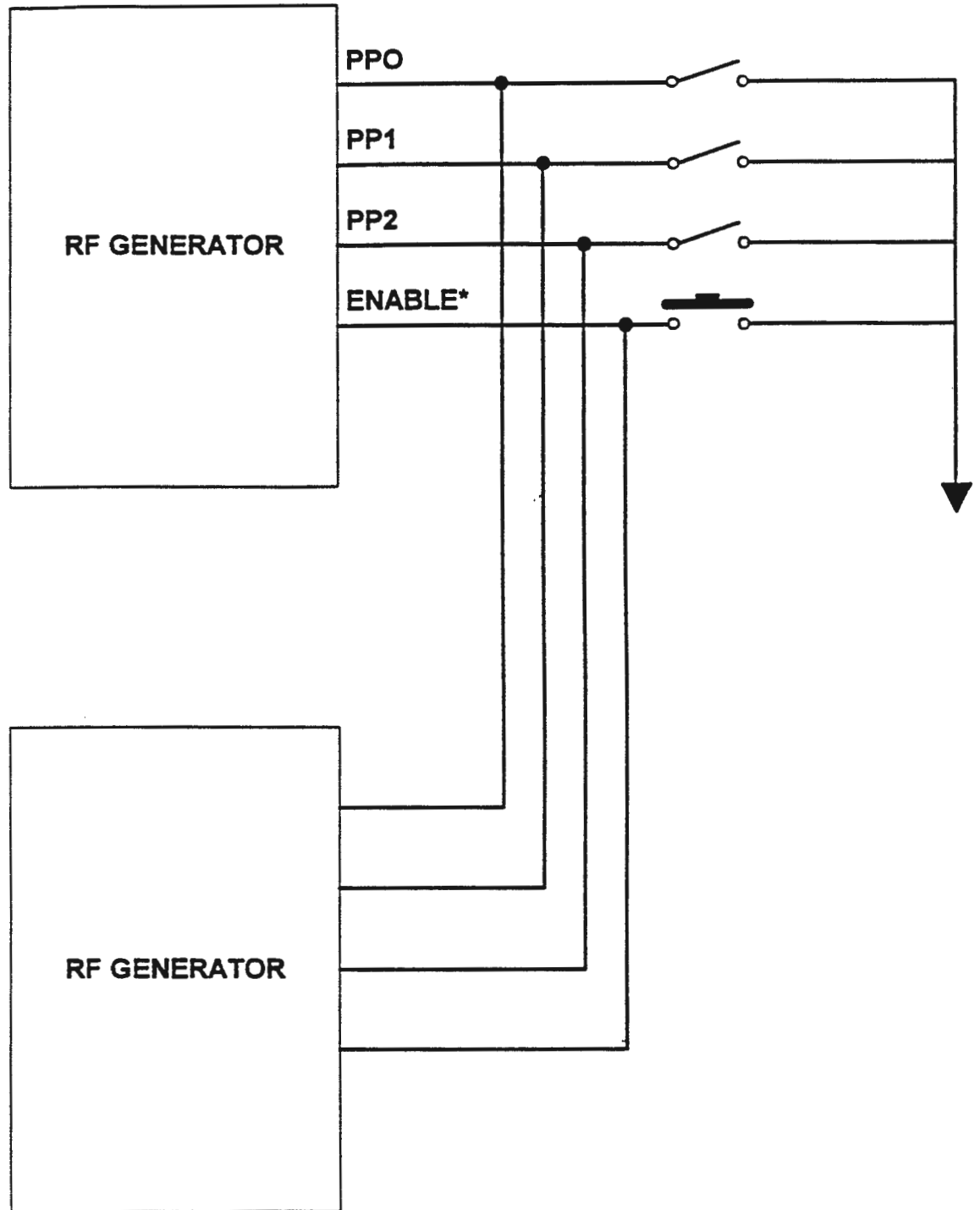

**FIG 18 FULL ANALOG DCV WITH PRESETS
(MATCHING NETWORK AND SEQUENCE)**

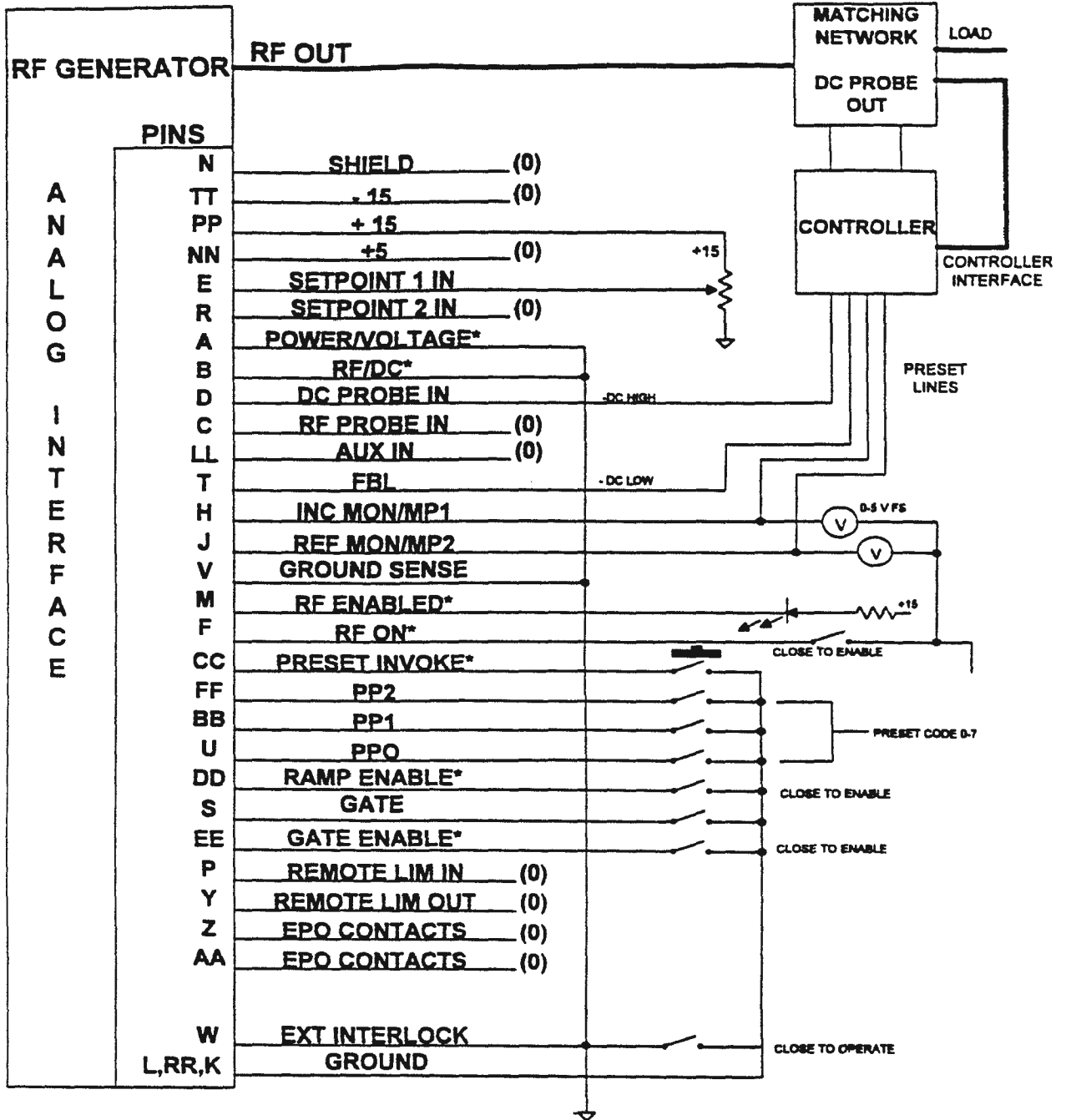

NOTES:
(0) INDICATES OPEN TERMINAL
*** INDICATES NEGATIVE LOGIC**

4.5.3 SERIAL

When operating under serial control of the generator, the desired preset is selected using the command "RUN".

At the "Command>" prompt in human mode enter the text string representative of the desired preset, a space and the command "RUN" followed by a carriage return. The text strings are as follows ...

<u>Text</u>	<u>Preset Selected</u>
DISABLE	Presets Disabled
P0	Preset # 0
P1	Preset # 1
P2	Preset # 2
P3	Preset # 3
P4	Preset # 4
P5	Preset # 5
P6	Preset # 6

ex. Command> P1 RUN <cr> ... to execute preset # 1.

In computer mode, enter the desired text string (see above), a space and the command "RUN" followed by a carriage return.

ex. P3 RUN <cr> ... to execute preset # 3.

NOTE: To save time/space the string "DISABLE" may be replaced with the ASCII character 0.

Additionally, the parameters of a programmable preset may be transmitted serially to the host computer or terminal at any time. This is accomplished via the serial commands P1?, P2?, P3?, P4?, P5? and P6? .

In human mode, the response to one of these queries might be ...

P2 Control RF Power
P2 Ramping Enabled
P2 Setpoint 400W
P2 Fwd Pwr Leveling
P2 Interval 0:01:00
P2 AutoSeq Disabled
P2 Jump to Preset 0

In computer mode, the response to the same query would be ...

3 1 400 0 60 0 0

4.6 PRESET CLOCK

This feature will display the length of time that the selected preset has been running. The time is displayed (if enabled) in place of the CEX and PULSE/RAMP/PST-# mnemonics on the bottom line of the Vacuum Fluorescent Display (VFD) in the STATUS ENVIRONMENT. The timer is reset whenever a new programmable preset is selected and is "frozen" when preset # 0 is selected (by an RF OFF or jump) or preset # 7 (presets disabled) is selected.

APPENDIX A

**TRANSFORMER LEGEND RF-20/30/HF-10
(SILKSCREEN SUPERSEDES MANUAL)**

NOM VOLTAGE	PHASE			JUMPERS		
	A	B	C			
198	2	7	12	2-8	7-13	12-3
208	2	7	12	2-9	7-14	12-4
220	2	7	12	2-10	7-15	12-5
230	1	6	11	1-8	6-13	11-3
240	1	6	11	1-9	6-14	11-4
250	1	6	11	1-10	6-15	11-5

190-260 VAC

NOM VOLTAGE	PHASE			JUMPERS
	A	B	C	
340	2	7	12	3-8-13-N
360	2	7	12	4-9-14-N
380	2	7	12	5-10-15-N
400	1	6	11	3-8-13-N
420	1	6	11	4-9-14-N
430	1	6	11	5-10-15-N

.....**340-450 VAC**

**TRANSFORMER LEGEND RF-5S/10S
(SILKSCREEN SUPERSEDES MANUAL)**

NOM VOLTAGE	INPUT	JUMPERS
99	2,3	2-6 3-7
108	2,4	2-6 4-8
115	1,3	3-7 1-5
125	1,4	4-8 1-5
198	2,7	3-6
208	2,8	3-6
218	2,8	4-6
230	1,7	3-5
240	1,7	4-5
250	1,8	4-5

RF-5S 95-130, 190-260 VAC

NOM VOLTAGE	PHASE	
	A	B
198	2	7
208	2	7
220	2	7
230	1	6
240	1	6
250	1	6

RF-10S 190-260 VAC