

HEWLETT-PACKARD JOURNAL

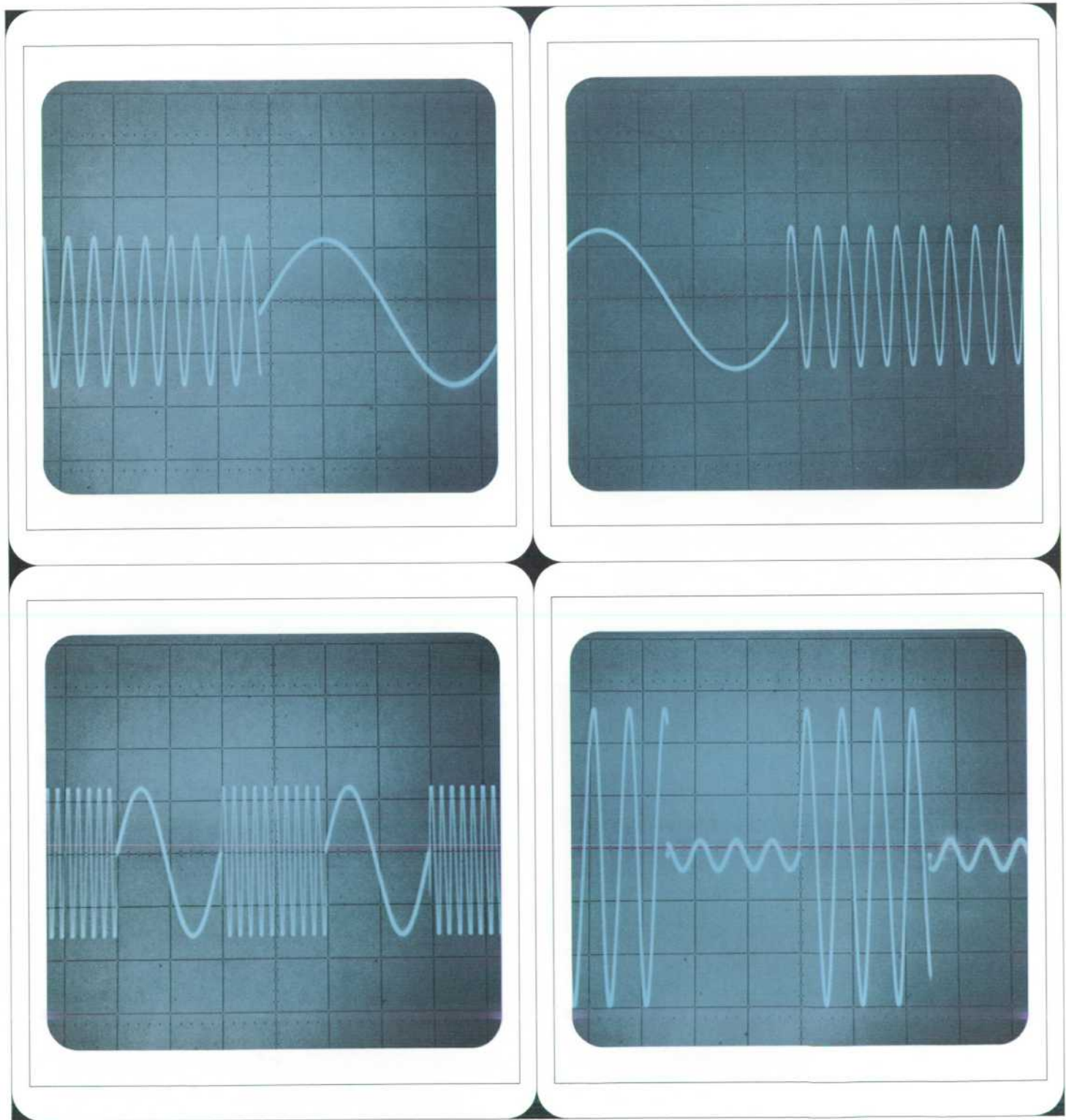

JUNE 1968

Many techniques are available to calibrate ac instruments, but the venerable thermal transfer method is still the best for . . .

High-Accuracy AC Voltage Calibration

By Fred L. Hanson

VERY PRECISE CALIBRATION OF AC INSTRUMENTS requires measuring equipment accuracy substantially greater than the required instrument accuracy. Many factors influence accuracy, including waveform distortion of the ac source and its short-term amplitude stability. Calibration techniques vary in complexity and in the time required to make a measurement. But it does not necessarily follow that great measurement accuracies require high cost, complex and tedious procedures.

A simple, direct method of ac calibration in the 1% accuracy region would use a single-frequency ac voltage

source with an absolute accuracy of about 0.2%. This single-frequency source (usually around 400 Hz) should have voltages available from hundreds of volts rms down to a few microvolts with enough steps to check ranging and tracking of a variety of analog voltmeters. With this source, the voltmeter can be calibrated to well within specs at mid-frequency. The frequency response of the instrument under test may then be determined with a stable, variable-frequency oscillator.

It is not difficult to get 300 volts at 400 Hz, nor is it difficult to get 3 volts at 10 MHz. But where high voltage is needed at high frequencies, it is usually necessary to use a tuned amplifier. Although it becomes necessary to readjust the tuning for changes in frequency, it does make possible an accurate high voltage at high frequency.

Distortion of the oscillator waveform is generally not a significant factor when calibrating average-responding

Cover: Oscilloscope photos demonstrate the transient-free switching of frequency and voltage ranges of the HP Model 745A AC Calibrator. Upper left, switching from 100 Hz to 10 Hz with sweep at 0.02 s/cm. Trace at upper right shows switching from 1 kHz to 10 kHz with sweep at 0.2 ms/cm. At the lower left, the output is switched between 100 Hz and 1 kHz. Sweep is 5 ms/cm; output is 1 V rms. Voltage switching from 1 V to 100 mV and back is shown at the lower right. Frequency is 80 Hz; sweep speed is 20 ms/cm.

In this Issue: High-accuracy AC Voltage Calibration; **page 2.** Effects of Distortion on Calibration; **page 6.** Systems-Oriented Digital Power Sources; **page 9.** Digital Voltage Sources at Work; **page 14.**

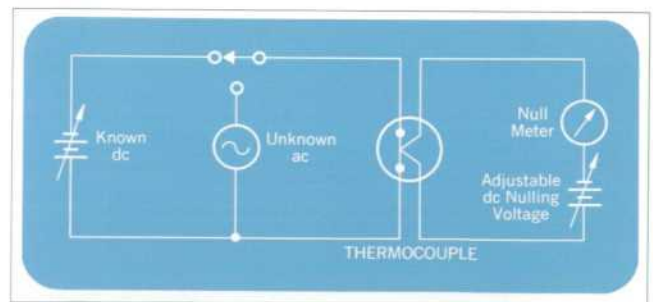

Fig. 1. Basic ac-dc thermal transfer measurement setup. By adjusting the voltages so a null is obtained for both the dc and unknown ac voltages, the rms value of the ac is equal to the known dc.

instruments in the 1% area of accuracy. Most oscillators have sufficiently low distortion so that calibration errors are less than a few tenths of a percent. With peak-responding instruments, however, the error due to distortion may become important. Distortion of 1% can cause 1% error or more.

High-Accuracy Technique

Methods used for calibration to about 1% are generally not very useful for higher accuracies. The basic, most highly regarded technique used to obtain ac voltage accuracy in the 0.01% area is the thermal transfer method — comparing the heating value of a dc current to that of an ac current, Fig. 1. A thermocouple is thermally connected to a heater wire through which the dc or ac current flows. The heating value of the applied current can then be determined by measuring the emf of the thermocouple. If the thermocouple emf is the same for both the ac and the dc currents, the heating values, and thus the rms values, of the two waves are the same. Since voltage level is determined by the heating effect of current in a straight piece of wire, the frequency range is extremely wide — from below 20 Hz to above 500 MHz.



Fig. 2. This new Model 745A AC Calibrator is a precision signal generator designed to provide ac voltages to $\pm 0.02\%$ accuracy at midband. Frequency range is continuously adjustable from 10 Hz to 110 kHz. The percent error scale enables direct error measurement without the necessity for calculation. Voltage, frequency, error ranges and frequency vernier may be programmed.

Problems in Thermal Transfer Measurement

The main objection to the use of the thermocouple transfer technique is the amount of set-up time required for each change in voltage and frequency. In addition, the procedure itself is time consuming.

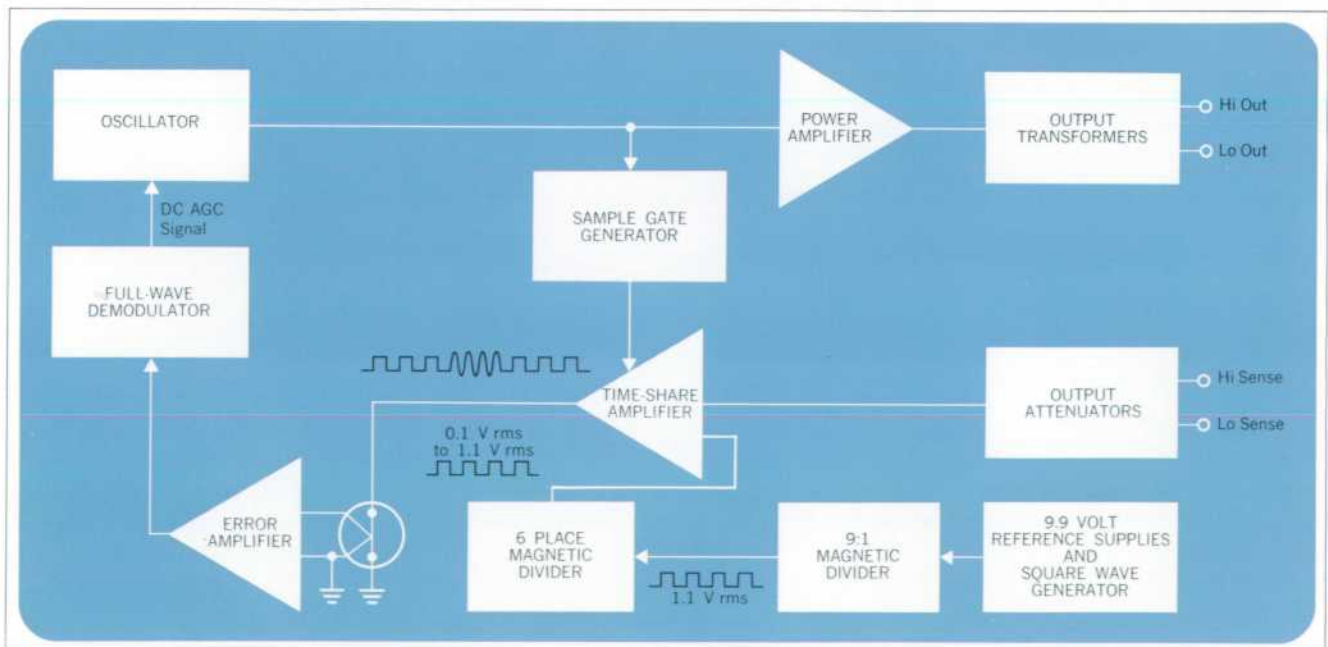

Fig. 3. Precise positive and negative 9.9-volt dc references are responsible for the accuracy of the Model 745A. The rms value of the square wave produced from these two voltages is the standard to which the oscillator rms voltage is compared. Oscillator output level is corrected by the AGC signal from the full-wave demodulator.

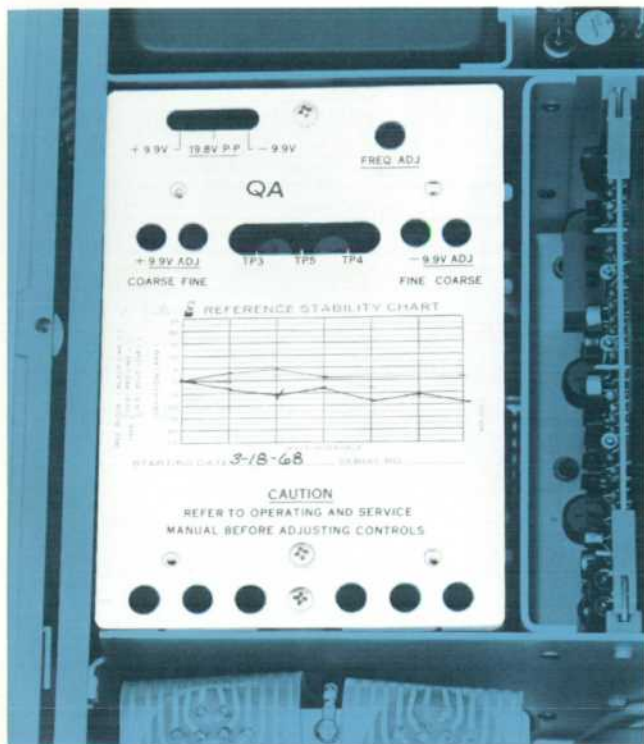

Fig. 4. Reference stability charts are plotted over a six week period to determine deviation in ppm of the reference zener diode and the 9.9 volt power supplies. A three-position switch, upper left, is used to connect the plus and minus reference supplies to a calibration point permitting calibration of the instrument with a dc voltmeter. The third switch position enables monitoring of the square wave.

Thermal reversal error compounds the above problem. Thermocouples do not always have the same voltage output for both direction of dc current. Therefore, this error must be averaged out by measuring thermocouple emf in both directions. This nearly doubles measurement time. With ac applied, the reversal is fast enough that thermal inertia prevents dissymmetry of heat distribution along the heater wire.

Switching Transients. With a multi-frequency ac source, frequency switching can result in significant transients. Since the most accurate wide-frequency systems use thermocouple transfer as a reference, these switching transients could result in a burned-out thermocouple.

Distortion. Errors (readings differing from true rms) due to distortion that are insignificant in the 1% area can have an effect when accuracy required is in the 0.01% area.^{1,2} Since a truly distortionless waveform is impos-

sible, it is necessary to know how much distortion is tolerable in any given measurement. The same amount of different-order harmonics can cause different errors. Too, the relative phase between harmonics and fundamental can alter the amount and, in some cases, even the direction of the error. The type of detector used in the voltmeter determines the amount of error that a particular distortion can cause. In other words, the effects of distortion on high-accuracy measurements are different for average-reading and peak-reading voltmeters.

Temperature Effects. Because of the high temperature coefficient of thermocouples (typically greater than 1000 ppm/°C), it is necessary to refer frequently to the dc reference. An arrangement can be devised with two thermocouples subject to the same ambient temperature and connected so that their outputs are in opposition. One thermocouple is connected to a stable dc source, and its output cancels out the emf shift due to temperature changes. This scheme results in some compensation, but does not solve the problem entirely.

Automatic Thermal Transfer

The new HP Model 745A AC Calibrator, Fig. 2, is designed to operate in the 0.01% area. A calibrated ac output is produced which is compared to a precision reference twice a second. Output frequency is continuously adjustable from 10 Hz to 110 kHz in four overlapping decade frequency ranges. Output voltage can be varied from 0.1 mV to 109.999 volts in steps of 1 ppm of full scale over the entire frequency range. Switching transients are held to insignificant levels.

The automatic thermal transfer method, Fig. 3, developed for the Model 745A overcomes the disadvantages of the classical ac-dc transfer method, and at the same time maintains most of the advantages. Instead of making time-consuming plus and minus dc readings and manually setting the ac, the automatic thermal transfer circuit makes the comparison twice each second, automatically adjusting the ac output voltage until its rms value equals that of the reference. The dc reference is a precision square wave, switching positive and negative so fast the thermocouple output is equal to the average for both directions of current. The output voltage is compared with the reference twice a second, and error caused by thermocouple drift due to temperature is eliminated.

Since the amplifier driving the thermocouple is common for both the ac signal and the dc reference, its gain accuracy and gain stability need not be considered. The amplifier is designed primarily for wide-frequency re-

¹ B. M. Oliver, 'Some Effects of Waveform on VTVM Readings,' *Hewlett-Packard Journal*, Vol. 6, No's 8, 9, 10, April, May, June, 1955.

² 'Which AC Voltmeter,' Hewlett-Packard Application Note 60.

sponse, and the system is capable of extremely good accuracy over a very wide frequency range. The greatest advantage gained is time. The ac-dc transfer measurement is done automatically twice each second; any voltage at any frequency can be set, and the ac output voltage immediately follows.

The instrument's accuracy is dependent upon the accuracy of the $+9.9$ and -9.9 dc reference voltages. These voltages are maintained by an aged zener diode held at a temperature of $80^{\circ}\text{C} \pm 0.1^{\circ}\text{C}$. By switching to these precise voltages alternately, a square wave is generated at a 500 Hz rate. To avoid errors due to voltage drops across the switches, all switching takes place within the feedback loops of the power supplies. Amplitude of the square wave is large enough so that thermal offset voltages, noise or other disturbances are insignificant.

Easy Calibration

Provision is made to calibrate the Model 745A using a dc rather than an ac voltmeter. Advantages include higher accuracy at lower cost, ease of use, and none of the uncertainties inherent in ac measurements. A three-position switch on the reference supply, Fig. 4, permits reading the voltage of either the plus or minus supplies, or checking the 500 Hz square-wave output.

The reference square wave thus established is 9.9 volts rms and is accurate to $\pm 0.001\%$. The square wave is applied to the input of a magnetic divider with a ratio of 9:1. The 1.1-volts rms output of the divider is applied to the input of a 6-place magnetic divider. With this 6-place divider, the square wave can be adjusted from 1.1 volts rms to 0.1 volt rms in $1 \mu\text{V}$ steps. The magnetic

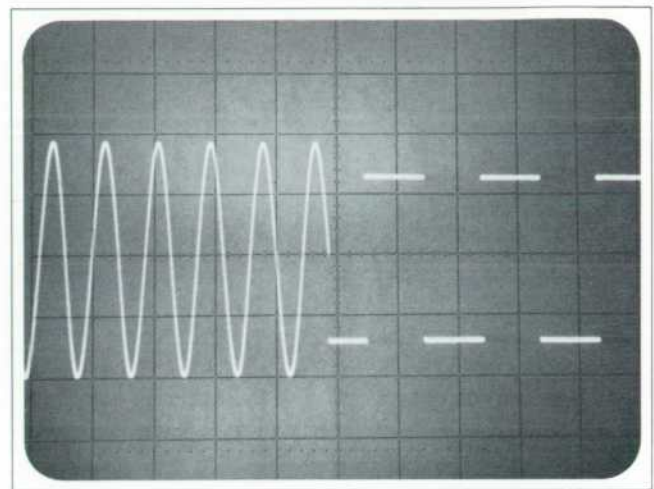

Fig. 5. Input waveform to the thermocouple. The sine wave is the instrument output, and the 500 Hz square wave is the reference. When there is an rms difference between these two, the thermocouple output is a 2 Hz square wave whose peak-to-peak value is proportional to this difference.

divider principle lends itself well to design for a wide frequency range, so the accuracy of the square wave is maintained.

Using the rms value of the square wave as a reference a comparison is made with the rms value of the Model 745A output voltage. On the 1-volt range, the voltage at the sense terminals is applied directly to one input of a time-sharing amplifier, and the reference square wave is connected to the other input.

The input to the time-sharing amplifier is then switched from the sine wave to the square-wave reference at a 2 Hz rate, Fig. 5. The output of the time-

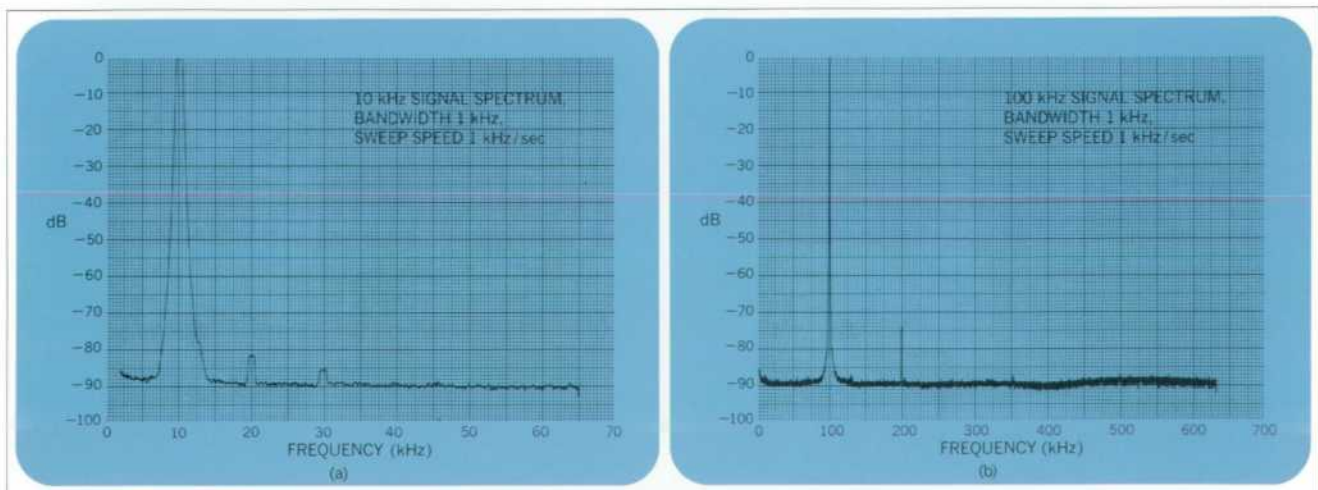

Fig. 6. Harmonic output of the Model 745A is better than 70 dB down, making it useful as a low-distortion oscillator, as well as a high-purity calibration standard.

Effects of Distortion on Calibration

In the field of precision measurements, the use of an ac voltage standard with more than about 0.5% distortion is avoided if possible. High quality oscillators used as signal sources rarely have harmonics beyond the third which contribute appreciably to calibration error. Only the effect of small amounts of second and third harmonics need be considered in determining the effects of distortion.

Effects of Harmonics on Average-Responding Meters

The accuracy with which an average-detecting voltmeter will read the true rms value of a waveform depends both upon the amount of distortion present and upon the phase relationships between the fundamental and its harmonics. The rms reading, E_{rms} , for $E_h \ll E_f$, is given by

$$E_{rms} \cong 1 + \frac{1}{2} \left(\frac{E_h}{E_f} \right)^2 \quad (1)$$

where E_h is the magnitude of the harmonic and E_f is the magnitude of the fundamental.

The reading of an average-responding meter is unaffected by the presence of small amounts of even, in-phase harmonics, since no area is added to the waveform. An rms reading differs from the average reading by

$$\frac{1}{2} \left(\frac{E_h}{E_f} \right)^2.$$

For a 0.1% second harmonic, the maximum error introduced is only 0.00005%. Second harmonics are usually not an important source of error in average-reading voltmeters.

For a quadrature phase relationship, the average value can be approximated by Eq. 1 and essentially no error is introduced.

A waveform containing odd harmonics results in considerably more error in the reading of an average-responding voltmeter. Errors caused by even harmonics always result in a lower reading, but errors caused by odd harmonics can result in higher or lower readings, depending upon the phase relationship between harmonics and fundamental.

The maximum area under the envelope (and the higher reading) occurs when the harmonic contributes the area of an extra one-half cycle to the fundamental. Subtracting a one-half cycle results in a low reading. For small amounts of third harmonic generally encountered in precision measurements, the maximum plus or minus errors that can occur are

$$Error \cong \frac{E_h}{3E_f} \quad (2)$$

The above equation gives total error, since small amounts of third harmonic have little effect upon the rms value. A third harmonic of 0.1% of fundamental could cause a change of 0.033% of the average reading, but only 0.00005% of the rms value.

For odd harmonics higher than the third, the half-cycle contribution becomes less, and the error decreases as the order of harmonic increases. Eq. 2 can be rewritten

$$Error \cong \frac{E_h}{nE_f}$$

where n is the order of the odd harmonic.

Effects of Harmonics on Peak-Responding Meters

For peak-responding voltmeters, the maximum error will occur when the phases of the wave components are such that a peak of the harmonic coincides with a peak of the

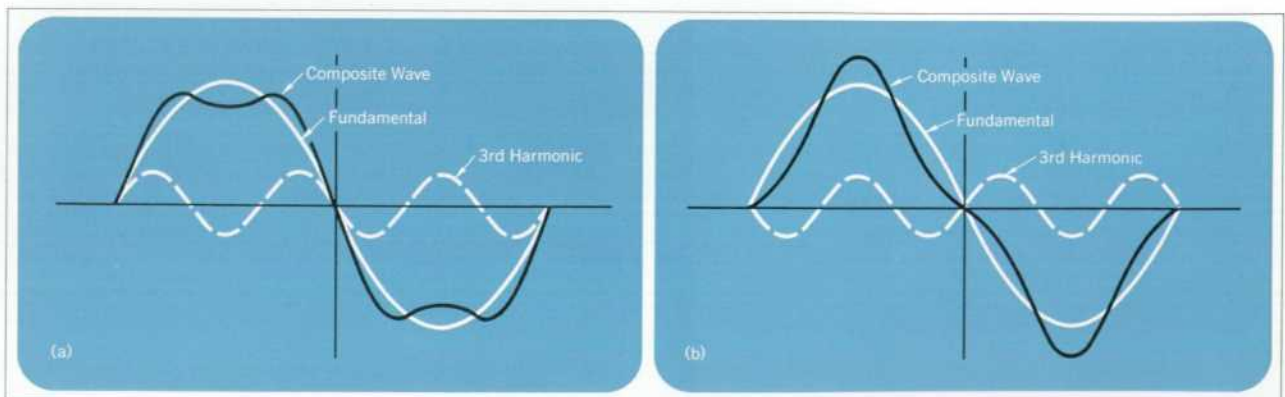

In-phase third harmonics (a) add the area of an extra half-cycle to the envelope and cause a higher than rms reading of an

average-responding meter, while an out of phase harmonic (b) results in a lower than rms reading.

fundamental. The maximum magnitude of the plus error (higher than rms value) will be the same regardless of the order of the harmonic. For small amounts of distortion, the maximum amount of error is plus or minus the amount of distortion directly.

A lower than rms reading occurs when the peak of the harmonic is in phase opposition to the peak of the fundamental. As the order of the harmonic, and/or the amount of distortion increases, peaks are formed adjacent to the peak of the fundamental. The meter will respond to these neighboring peaks. As their amplitude increases, the meter error approaches that of the maximum (higher-than-rms) reading.

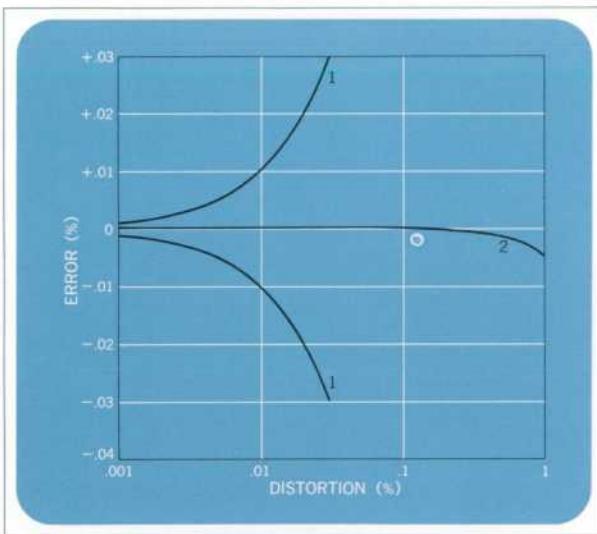

Effect of even harmonics on average-reading voltmeters (Curve 2), and on peak-reading voltmeters (Curve 1).

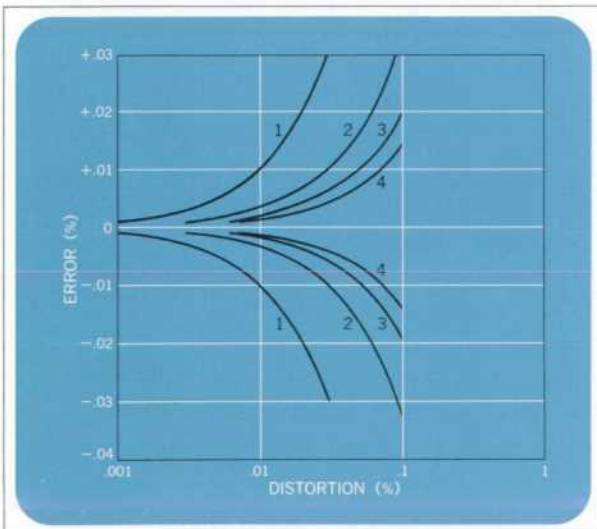

Effect of odd harmonics on average-reading voltmeters (Curves 2, 3, 4), and peak-reading voltmeters (Curve 1).

sharing amplifier is applied to a 50 ms time-constant thermocouple. The thermocouple heater is at such a temperature that the output emf of the thermocouple is about 7 mV. If the rms value of the sine wave is different from that of the square wave, the output emf of the thermocouple will change each time the time-sharing amplifier switches. If the sine wave and square wave differ by 0.01%, the output of the thermocouple will change by 1.4 μ V at a 2 Hz rate. Following the thermocouple is an ac amplifier designed to amplify only this 2 Hz signal, and ignore any dc drift of the thermocouple. Its output is demodulated and the resulting dc used to control the voltage level of the oscillator, and thus the output voltage of the Model 745A.

The gain of this feedback loop is 100 dB, so any changes in amplifier gain or oscillator output are reduced by 10^5 . On the 1-volt range, the rms voltage at the output is maintained essentially equal to the rms voltage of the square wave at the output of the 6-place magnetic divider.

Additional voltage ranges are obtained by using a set of transformers to transform the voltage on the output of the power amplifier to that required for any of the six voltage ranges. The accuracy of the 1-volt range is dependent only upon the accuracy and stability of the dc voltages making up the square wave. Since the magnetic dividers are not subject to the drift or temperature effects as resistive dividers, they have no effect upon the accuracy of the 1-volt range.

Accuracy of the other voltage ranges is affected by output attenuators as well as the dc reference voltage. For this reason, all the ranges from 10 volts down use inductive dividers, so that problems due to temperature changes and long-term drift are eliminated. The 100-volt range divider is not magnetic because of physical size limitations. A precision wirewound resistive divider is used on the 100-volt range (and on a soon-to-be-available 1000-volt range), and is designed so it can be calibrated with dc. Thus, it is possible to set the ratio of this divider to within $\pm 0.001\%$, which would be extremely difficult with ac measurements. After dc calibration of the attenuators and the 9.9-volt reference supplies, it is only necessary to check frequency response on the 1, 10, 100 and (future) 1000-volt ranges for complete calibration.

Oscillator

Essentially a synthesizer type, the oscillator used in the 745A uses a diode ring as a final mixer, resulting in an output voltage with extremely low distortion. Total

SPECIFICATIONS

HP Model 745A AC Calibrator

RANGES

OUTPUT VOLTAGE RANGES: 6 ranges* with 10% over-range as follows:

Range	Setability
1 mv	0.100000 mV to 1.099999 mV in 1 nanovolt steps
10 mv	1.00000 mV to 10.99999 mV in 10 nanovolt steps
100 mv	10.0000 mV to 109.9999 mV in 100 nanovolt steps
1 V	0.100000 V to 1.099999 V in 1 microvolt steps
10 V	1.00000 V to 10.99999 V in 10 microvolt steps
100 V	10.0000 V to 109.9999 V in 100 microvolt steps

OUTPUT FREQUENCY RANGES: continuously adjustable from 10 Hz to 110 kHz in 4 decade ranges with 10% overlap.

ERROR MEASUREMENT: 2 ranges with zero center dial, $\pm 0.3\%$ or $\pm 3\%$.

PERFORMANCE RATING

ACCURACY: accuracy holds for a 90-day period and is met after a 1-hour warmup period at $25^{\circ}\text{C} \pm 5^{\circ}\text{C}$ with $< 95\%$ R.H.

*Companion amplifier providing a 1000 V range to be announced.

VOLTAGE: specifications by the National Bureau of Standards.

Range	Accuracy
50 Hz to 20 kHz	$\pm (0.02\%$ of setting $+ 0.002\%$ of range $+ 10 \mu\text{V})$
20 Hz to 50 Hz	$\pm (0.05\%$ of setting $+ 0.005\%$ of range $+ 50 \mu\text{V})$
10 Hz to 20 Hz	$\pm (0.2\%$ of setting $+ 0.005\%$ of range $+ 50 \mu\text{V})$

Frequency: $\pm 2\%$ of setting, $\pm 0.2\%$ of full scale.
Error Measurement: $\pm (0.5\%$ of setting $+ 0.5\%$ of range)

TEMPERATURE COEFFICIENT:

Voltage: $\pm 0.0003\%$ of setting per $^{\circ}\text{C}$ from 0°C to $+55^{\circ}\text{C}$.
Frequency: $\pm 0.05\%$ of range per $^{\circ}\text{C}$ from 0°C to $+55^{\circ}\text{C}$.

VOLTAGE STABILITY: Stability met after 1-hr warmup period at constant temperature with $< 95\%$ R.H.
Long-Term: $\pm 0.01\%$ of setting for 6 mo.
Short-Term: $\pm 0.002\%$ of setting for 24 hr.

OUTPUT CHARACTERISTICS

TOTAL DISTORTION AND NOISE: $\pm (0.05\%$ of setting $+ 10 \mu\text{V}$ over 100 kHz Bandwidth) on all ranges.

TOTAL DISTORTION, Cycle-to-cycle Instability, and Noise: Will cause $< \pm 0.005\%$ of error when used to calibrate an average-responding or true rms-responding instrument from 1 mV to 110 V.

MAXIMUM CAPACITIVE LOAD: 1000 pF on all ranges.

OUTPUT TERMINALS: high and low output terminals can be floated ± 500 V dc above chassis ground.

COUNTER OUTPUT: rear-panel frequency counter output, $2.2 \text{ V} \pm 20\%$, protected against short circuits.

REMOTE PROGRAMMING

Voltage, Frequency, Error Ranges, and Senses	Requirements
Contact Closure	Less than 400 Ω to ground
NPN Transistor Reed Switch Through Diode NPN Transistor Through Diode	Open circuit voltage $< 5 \text{ V}$. Short circuit current 2 mA. Maximum voltage on programming line at closure 0.8 V.

Frequency Vernier	Minimum to Maximum of Range
Analog Voltage	$+ 1 \text{ V}$ to $+ 10 \text{ V DC}$
Resistance to ground	500 Ω - 10 k Ω

GENERAL

POWER REQUIREMENTS: 115 or 230 V $\pm 10\%$, 50 Hz to 400 Hz, 70 W nominal, 100 W maximum.

WEIGHT: net 65 lbs (29.3 kg);
shipping 75 lbs (33.8 kg).

PRICE: HP 745A, \$4500.

MANUFACTURING DIVISION: LOVELAND DIVISION
P.O. Box 301
815 Fourteenth Street S.W.
Loveland, Colorado 80537

output distortion of the instrument, Fig. 6, shows that the error introduced in an average responding voltmeter is less than 50 ppm. Frequency range switching within the oscillator is electronic rather than mechanical, which gives an essentially transient-free waveform when changing frequency ranges (see cover). When a change in frequency requires a change in output transformers, there is a slight transient, but never enough to harm delicate devices connected to the output.

Electronic frequency range switching enables easy programming of the oscillator. A closure to ground on the appropriate programming pin selects the frequency range. The vernier frequency is also programmable by applying a dc voltage to a programming pin or by a selected resistance to ground at the same pin.



Fred L. Hanson

Fred Hanson received his Bachelor of Science and Masters degrees in Electrical Engineering from Utah State University in 1962 and 1963. He joined Hewlett-Packard in 1963 and worked on the Model 741A AC-DC Differential Voltage/DC Standard. He also worked on development of test equipment for calibration of the ac converter in the Model 741A. This assignment led to development of the Model 745A for which he became design leader.

Production Line Uses

With the ability to make a highly accurate ac calibration in a relatively short time, the Model 745A is especially suited to production line testing. Especially skilled operators are not required. A percent-error readout eliminates time-consuming error calculations, and is valuable where large numbers of instruments are calibrated. Calibration error is displayed directly in percent of setting, with a resolution of 0.001%.

Programmability

Many applications of the Model 745A in automated systems are possible because of its remote programming capability. Voltage, frequency and percent-error may be remotely programmed by transistor or switch closures to ground. Output frequency may be varied with an adjustable analog voltage, or programmed by switching resistances to ground.

Acknowledgments

Many people made significant contributions to the development of the HP Model 745A. Product design was by Bob Moomaw and Billy Miracle. Perry Wells designed the oscillator section, Chuck Platz is responsible for design of the output amplifier, and Ben Lizardi for the reference square-wave generator. Much valuable assistance in the project's definition and direction was given by Bill Smith, group leader during a portion of the project.

Systems-Oriented Digital Power Sources

Designed specifically to be programmed by a computer, this new digital power supply is tailor-made for automatic test systems.

By Brett M. Nordgren

THE TREND IN TESTING TODAY IS TO AUTOMATION. More and more frequently, instruments are being called upon to operate as parts of large systems, usually computer-controlled. Most of these systems require one or more voltage sources which are capable of being programmed by the computer.

Specifically to meet the needs of the systems environment, we undertook development of a digitally programmable power supply which would combine all the elements required to take a digital signal from a computer and produce a 50-watt output to a load. The result is Model 6130A Digital Voltage Source, Fig. 1. The new instrument is basically a high-speed solid-state digital-to-analog converter followed by a bipolar dc power amplifier. It also has signal-conditioning and data-storage circuits, current-limiting circuits, and gate and timing circuits which facilitate communication with the computer. Easy accommodation to a variety of computers was an integral design requirement.

With all of these elements in one instrument designed for systems operation, the systems designer no longer has to combine several different devices which in all probability were not optimized either for systems operation or for operation together.

One of the principal reasons for automatic testing is high-speed operation. Recognizing this, we emphasized speed in the design of the new digital voltage source. Its output voltage can be programmed over its full range in less than 100 microseconds. 10,000 voltage changes per second are possible. The data storage circuits in the voltage source also contribute to overall system speed and efficiency. These circuits hold the input data so the computer doesn't have to

keep transmitting the data while slower circuits are responding to it. Thus the computer uses less time in data transmission and has more time for other operations.

Isolation is another important systems requirement designed into the new voltage source. Frequently it isn't possible to have the output grounded to the same point as the input data signals. Therefore, we have provided circuits which isolate the input from the output.

Model 6130A Digital Voltage Source accepts four-digit BCD or fifteen-bit binary input data, and supplies up to $\pm 50V$ at one ampere. It can sink up to 500 mA.

High-Speed D-A Converter

The functions of the new digital voltage source can be divided into five groups (see Fig. 2). The circuits corresponding to each group are on a single plug-in card.

The heart of the instrument is the digital-to-analog converter, which takes digital input information and con-



Fig. 1. New Model 6130A Digital Voltage Source is specifically designed for computer programming. It has four-digit accuracy and resolution and takes less than 100 μs to change output voltages. It can supply up to ± 50 volts at 0 to 1 ampere. A low-powered version, Model 6933A Digital-to-Analog Converter, takes only 20 μs to change voltages.

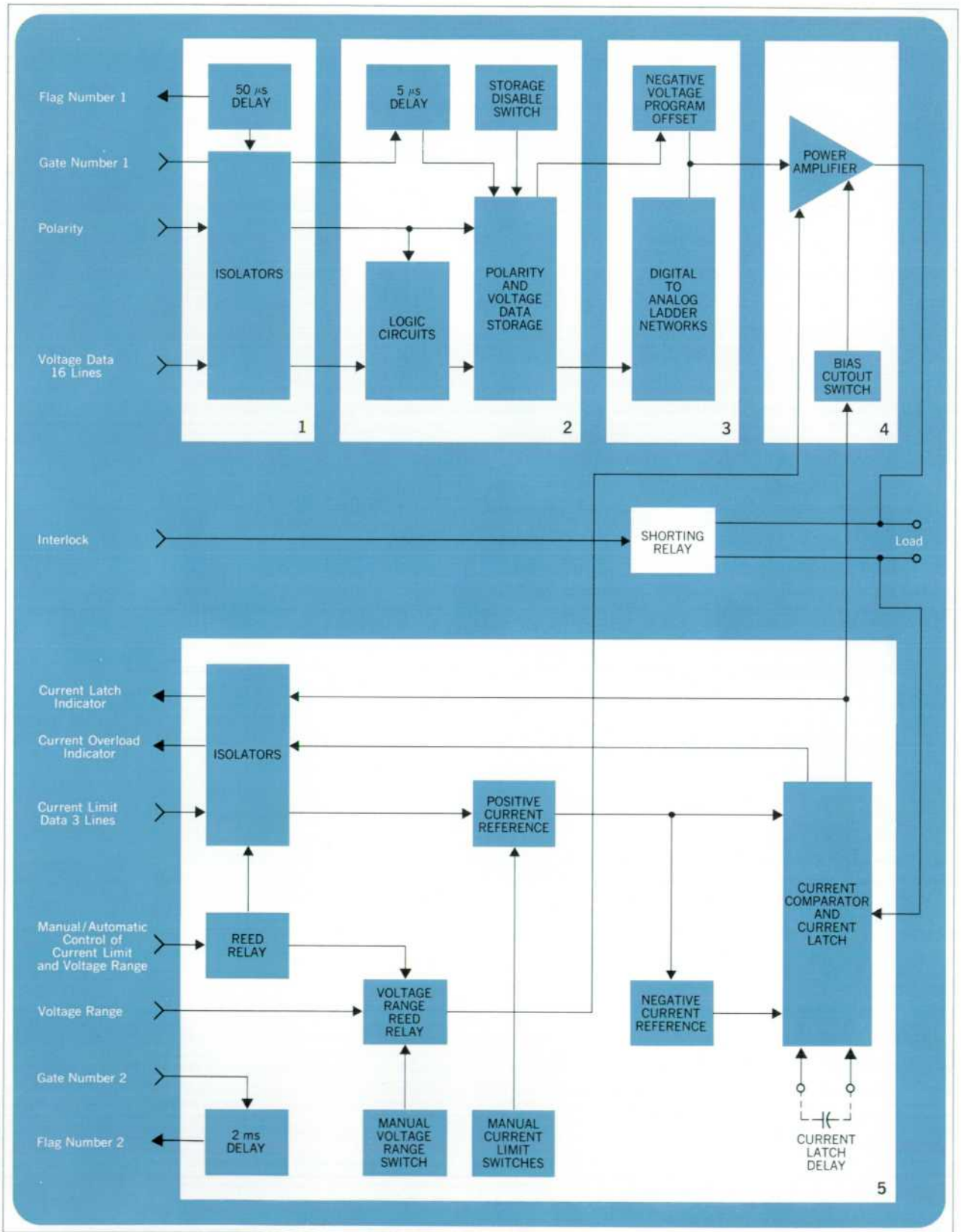

Fig. 2. Five plug-in cards hold most of the circuitry of the Model 6130A Digital Voltage Source. Basically a D-A converter followed by a precision power amplifier, the voltage source also has input-to-output isolation which breaks ground loops, storage circuits which prevent transients and improve noise immunity, and current-limit circuits.

verts it into an analog reference signal, accurate to within five parts in 10^5 of its maximum value. This reference signal drives the precision power amplifier. The D-A converter output is connected to the summing point of the power amplifier, which is a virtual short circuit. Thus the short-circuit output current of the D-A converter is the reference signal that drives the amplifier.

D-A converters contain a series of switches which are activated by the input data bits. The switches act on a resistance network which produces an output proportional to the numerical value of the input information. In the new digital voltage source the resistance networks are 1R-2R ladders, Fig. 3.

The switches in the new instrument are saturated transistors. They give a speed improvement of two orders of magnitude over relay switches, yet maintain overall accuracy within $\pm 0.01\%$. Careful choices of semiconductors and bias conditions were needed to satisfy both of these requirements.

The digital voltage source can be built to accept either binary-coded-decimal (BCD) or binary inputs. When the input is in BCD form, four ladder networks are used, each containing four bits. Their outputs are weighted in powers of ten.

When the input is straight binary, again four ladders are used, three containing four bits and one containing three bits, and the weighting is in powers of sixteen. If a single chain of fifteen bits were used for binary inputs, voltage drops in the ground lead of the ladder network, caused by the base currents of the transistor switches, would result in error-producing interactions between the lower-weighted bits and the higher-weighted bits. Grouping the input data into sets of bits reduces these interaction errors, and makes adjustment easier as well.

Bipolar D-A Converter Output

The D-A converter accepts either a positive or a negative input number and supplies a corresponding positive or negative output. To make the circuit bipolar in this way, an unusual design approach was taken. Because they use linear networks, D-A converters are fundamentally unipolar. This means that the output signal of a D-A converter always becomes larger as the numerical magnitude of the digital input increases. But when the input calls for a negative sign, the converse must occur if the D-A converter is to be bipolar. We found that the least space and expense would be required if we let digital integrated circuits take most of the burden of polarity changing. Here is how it works. Suppose the input consists of four decimal digits and one sign bit. A

negative sign bit causes the digital circuits to convert the input number into its nines complement; that is, $-(N)$ is converted into $(.9999 - N)$. The negative sign bit also turns on an accurate current of $-.9999$ mA. This is added to the D-A converter output. Thus the analog output is $(.9999 - N) - .9999$, which is $-(N)$, as desired.

Polarity changing is easier for the binary input option. Negative binary numbers are commonly represented by the two's complements of the corresponding positive numbers, so no complementing need be done by the digital voltage source. It is only necessary to switch on an appropriate current offset for negative numbers.

To maintain accuracy over a range of environmental conditions, the voltage-reference diode in the D-A converter of each instrument is individually biased for minimum temperature coefficient. All critical resistors are low-temperature-coefficient types, some having TC's of 2 ppm per degree C, some 5 ppm per degree C, and some 1 ppm per degree C.

Input-Output Isolation Needed

Anytime that digital voltages are used to program a power supply, there should be no connection between the LO output terminal of the power supply and the ground point of the digital inputs. Such isolation is necessary for a number of reasons. First of all, the power supply must be able to operate with its LO output con-

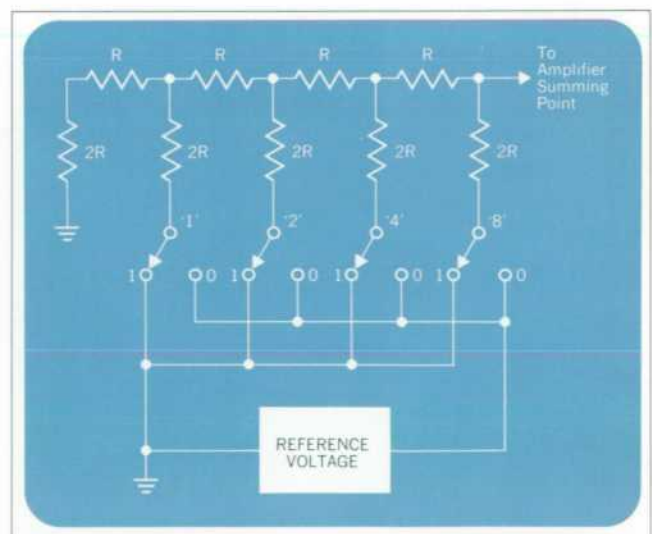

Fig. 3. This is the 1R-2R ladder used for digital-to-analog conversion in the Model 6130A Digital Voltage Source and the Model 6933A Digital-to-Analog Converter. Transistor switches are used, giving a speed improvement of more than 100 over relays. Each instrument has four of these ladders.

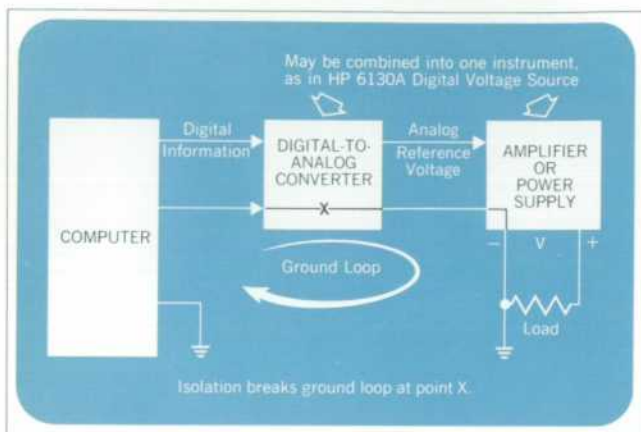

Fig. 4. Whenever a power supply is programmed digitally, there should be no connection between the ground of the digital inputs and the ground of the analog output. Without isolation, small voltage drops in the power supply leads can cause large circulating ground-loop currents. In the new digital voltage sources, isolation is provided by oscillators with transformer-coupled outputs, one for each input data bit.

nected to some point which is not at ground potential. However, the digital input information is usually referred to ground. If the LO output terminal were common with the input ground, and then were connected to a load terminal which is not at ground potential, a short circuit would exist between the data ground and the load terminal. To prevent this, isolation is needed.

Furthermore, even when the input and output are referred to the same point, isolation is needed to break ground loops (see Fig. 4). Suppose that the system is being programmed by a computer. The data voltages in a computer are referred to the computer chassis, which is grounded. Even if the load is also grounded, stray ac magnetic fields can cause large ripple currents to circulate in the ground leads. The dc voltage drop in the power leads can also cause large circulating currents. By breaking the ground loop, isolation eliminates these currents.

Finally, isolation prevents potentially destructive current surges which would otherwise occur if some point in the load circuit should be unintentionally grounded.

In the new digital voltage source, isolation is achieved by using small transformer-coupled 10-MHz oscillators, one per bit. The input signals turn on appropriate oscillators, and the RF transformer outputs are rectified, filtered, and sent on to the following digital circuits. An important advantage of this design is that the digital

inputs respond to dc levels. Dc coupling of the data makes it possible to limit the input bandwidth in particularly noisy environments. This could not be done if, for example, pulse transformers were used to obtain isolation and the data transmitted as pulses.

Storage Improves Efficiency

Instead of requiring data to be present at all times at the input, all input lines are connected to integrated-circuit storage buffers. This allows the computer to transfer data to the voltage source and then go on to other tasks without having to maintain the input signal. The computer simply transmits the data and, over a separate line, a gate pulse which causes the data to be transferred into the storage buffers. This system also allows 'party-line' operation, in which one set of data lines feeds several voltage sources. Each voltage source has its own gate-pulse line, and the computer sends a gate pulse only to the unit for which the data is intended.

Besides their storage function, the storage buffers offer additional advantages. First, the gate pulse which causes new data to be transferred into the storage buffers can be, and is, delayed for 5 μ s from the arrival of the data. This allows all input lines to settle and eliminates errors due to crosstalk. Data can be carried over ordinary twisted-pair cables without difficulty. Second, since the storage buffers immediately precede the D-A converter, they ensure that all data bits reach the D-A converter almost simultaneously, regardless of variable delays in the input circuits and data lines. Since the slewing capability of the power amplifier is 4 volts per microsecond, sub-microsecond variations in the delays encountered by different bits could result in programming transients of over a volt, if there were no storage. For example, when programming from 7 volts to 8 volts, if the '8' bit arrived before the '4', '2', and '1' bits disappeared, the output would momentarily be trying to go to 15 volts. Storage prevents this.

Reactive Loads Not A Problem

The accurate reference signal from the D-A converter goes directly to the power amplifier. To preserve the accuracy of the reference signal, large amounts of negative feedback are used in the amplifier circuits. The input stage of the power amplifier is a high-gain differential-pair transistor circuit. This is followed by six more stages of gain before the output stage. The current gain of the active devices is 10^{10} , and the open-loop gain of the amplifier is greater than 10^4 . Gain crossover is at 50 kHz, so the rolloff must be controlled up to 5 MHz.

Power supplies have to be able to operate with reactive loads. Inductive loads present no problem, but capacitance added to the load adds an additional pole to the feedback-loop characteristic of the power amplifier. When the open-loop gain is high, the additional pole may give the amplifier a tendency to oscillate. We have found that open-loop output impedance is a critical factor — the lower it is, the less the tendency to oscillate. To allow capacitive loads to be tolerated by the new digital source, its open-loop output impedance is designed to be of the order of two ohms. This shifts the troublesome pole to a very high frequency where it does no harm. Capacitances of $1 \mu\text{F}$ can be driven without difficulty; even with this large a capacitance the output voltage will not overshoot its programmed value more than 5%. (With resistive loads overshoot is less than 0.1%.)

Overcurrent Protection Also Programmable

To protect the load device in the event that it draws more current than anticipated, and to protect the voltage source against accidental short-circuiting of its output terminals, the instrument contains two separate current limiting circuits. One circuit limits the current to 1.1 amperes to protect the power-output transistors. The other circuit is a programmable trip circuit which shuts off the bias voltages to the output stages when an overcurrent condition is detected. Current limits of 20 to 1000 mA can be programmed. This circuit acts within $5 \mu\text{s}$ to raise the output impedance to $20 \text{ k}\Omega$, thus limiting the current to a safe level. Should the load be one that must be allowed to draw an initial heavy transient current, the disconnect reaction can be delayed by as much as 2 ms by adding a capacitor to rear-panel terminals.

(continued on back cover)

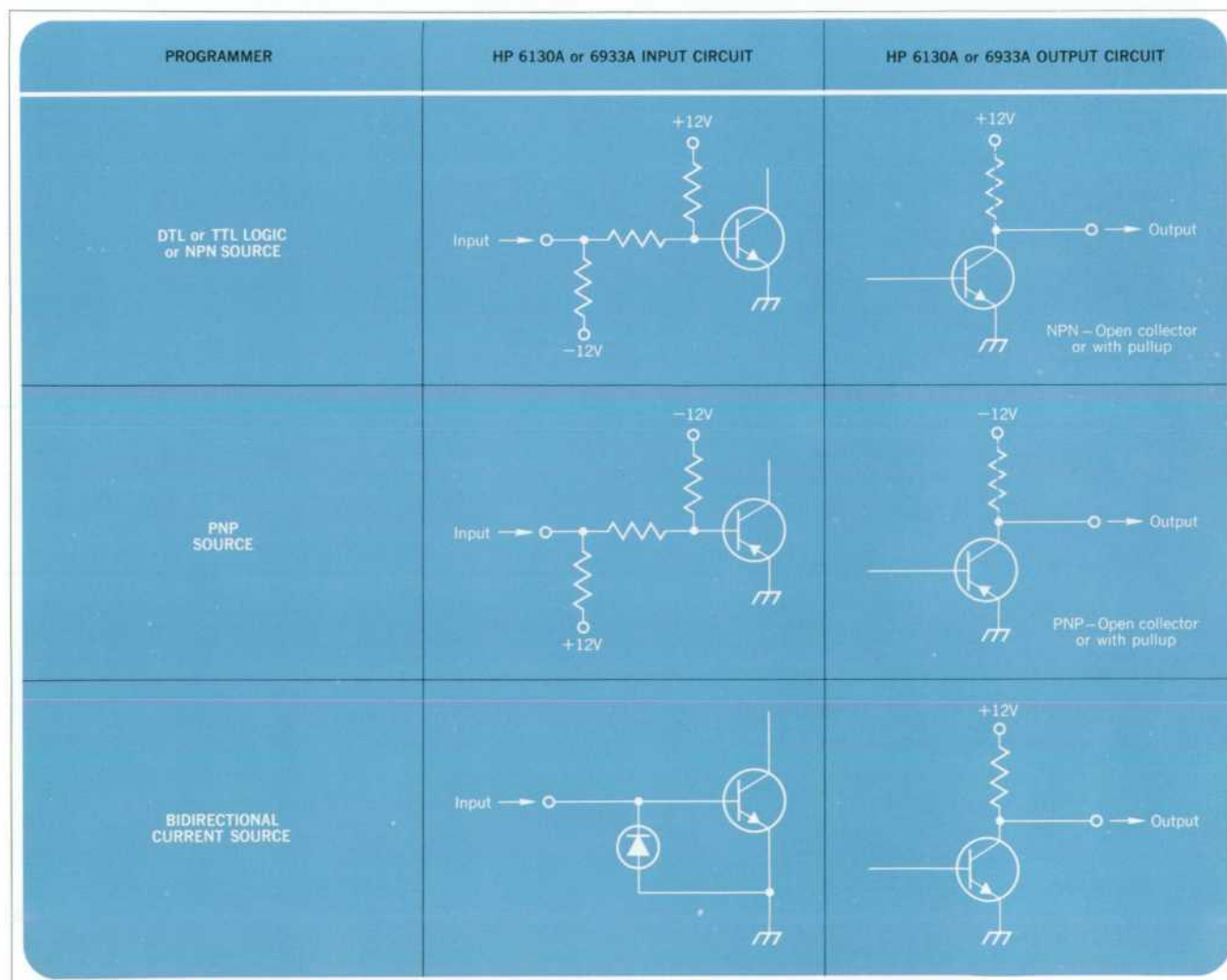

Fig. 5. Input and output circuits of the new digital voltage sources are designed to be easily modified to accommodate a variety of data sources. Here are some of the options.

Digital Voltage Sources at Work

Model 6130A Digital Voltage Source combines into one instrument the functions needed for operation as a computer-controlled power supply in an automatic test system. Here are some systems which illustrate its capabilities and possibilities.

Semiconductor Testing

Testing semiconductor devices with automatic systems is already a way of life in the electronics industry. The new digital voltage source can play several important roles in these systems (see Fig. 1).

Programmable voltage sources are most commonly used to set the bias conditions for the device being tested. Frequently these conditions may have to be changed for each measurement, perhaps as many as 20 or 30 times for one complete test. Here the speed of the new power supply is valuable, because it allows tests to be completed in less time. It also reduces the equipment required, since it can do things that otherwise would require 20 or 30 separate power supplies.

The digital voltage source can also be used to set the supply voltages for integrated circuits undergoing tests. Worst-case combinations can be programmed rapidly. The voltage source's freedom from programming transients is important in testing circuits like this, since they cannot tolerate voltages that exceed their ratings, even briefly.

For some circuits, the digital voltage source can be used to generate input signals. For example, it is possible to determine the switching thresholds of digital circuits quite accurately by programming an input staircase waveform which has steps of one millivolt. For go/no-go tests, pulses

less than 100 μ s wide can be generated with amplitudes accurate within ± 1 mV. The current-sinking capability of the new voltage source permits it to simulate a variety of logic drivers, including the current-sinking types which ground the input terminal of the logic circuit and draw current out of it. Its current-limiting circuits are also important here; they have current-limit settings of 20 to 1000 mA, and can quickly recognize abnormal conditions.

Waveform Generation

Generation of arbitrary waveforms by the digital voltage source is entirely feasible because, with its data rate of 10,000 words per second, it can respond to 10,000 voltage-change commands per second from the computer. Such waveforms could be anything from a simple staircase function to a digitally approximated random noise function. An example of a waveform generated by the voltage source is shown in Fig. 2. This 35-Hz wave was synthesized with 360 steps per cycle. To synchronize the oscilloscope observing the waveform, an initial spike 50V high and 60 μ s long was programmed.

Systems Testing

Checkout of large electronic and electromechanical systems, such as might be found in aircraft or in space hardware, is facilitated in several ways by using digitally programmed power sources. A current approach to system checkout is the concept of 'stimulus-response' testing, in which a controlled stimulus signal is introduced into a system for the purpose of observing its response and evaluating its performance. With its 50-watt output capability, the digital voltage source can drive small motors, simulate supply voltage variations, act as an active load, and generate programmed stimulus waveforms. It can also stimulate closed-loop control systems with realistic input waveforms; for example, torque motors can be attached to the output

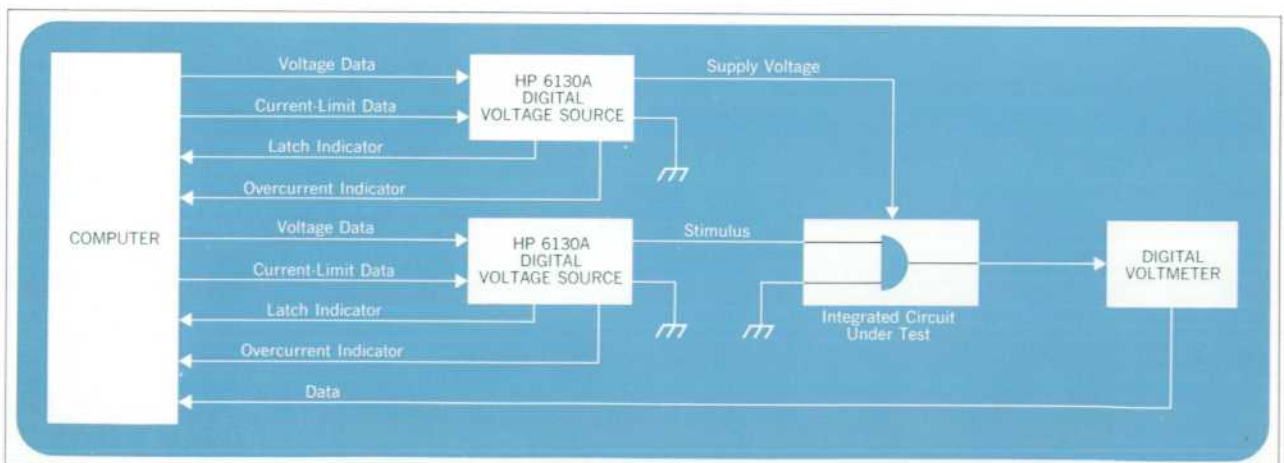

Fig. 1. Semiconductor Testing

of a servo positioning system and be driven with the aid of a digital source to simulate expected loading transients. Many of these transients, such as wind loading of an aircraft's control surfaces, are low-frequency waveforms which are difficult to generate other than digitally.

Optimizing Bias

An interesting application for the digital voltage source came about as a result of a problem which arises in its own manufacturing process. The voltage reference diode in every instrument must be biased at precisely the proper current to obtain minimum temperature coefficient. Finding this current is a process of educated guessing. It requires varying the diode temperature, observing the output voltage variation, adjusting the diode current, and then trying again.

A rough mathematical model of the diode's voltage-temperature-current relationship can be derived. Now a computer can set the temperature and the bias currents, using a Model 6130A Voltage Source as the bias supply (see Fig. 3). The diode's voltage changes are measured by a digital voltmeter and transmitted to the computer, which calculates its best guess of the correct bias current on the basis of the mathematical model. After a few tries, the optimum current is arrived at and recorded. The computer also knows the supply voltage and calculates the value of the bias resistor needed to set the bias current to the proper value. The test takes two minutes; it would take 30 if done manually.

Process Control

Direct digital control of processing plants involves numerous interfaces between the central process controller and peripheral devices. One such interface is encountered when digital signals are used to operate motors or proportioning valves. Here the aim is to cause a response which is proportional to the magnitude of the digital signal applied. The

digital voltage source can deliver up to 50 watts for such applications. Its isolation between input and output allows the data and load circuits to have different ground potentials if necessary.

Calibration

To calibrate digital instruments, it is often best to use digital devices. For instruments needing calibration signals accurate to within 1 mV, the new digital voltage source can be used in a computer-controlled, closed-loop test system (see Fig. 4). The computer programs the voltage source, and the source's analog output is applied to the instrument being tested, which might be a digital voltmeter, a digital panel meter, or an analog-to-digital converter. The computer then monitors the instrument's response and compares it with the number that was programmed. Doing the test digitally avoids the difficulties inherent in working with small differences between analog voltages.

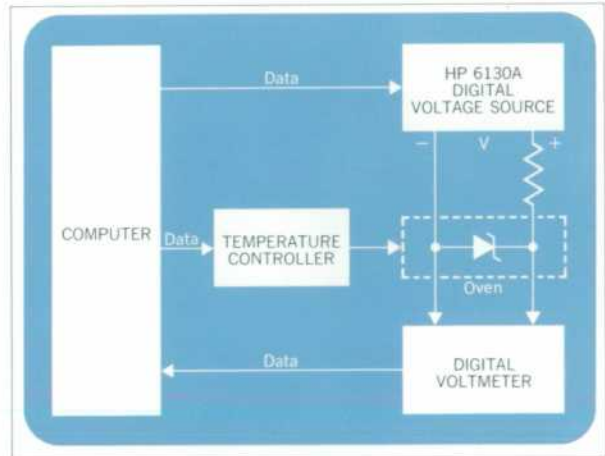

Fig. 3. Optimizing Bias

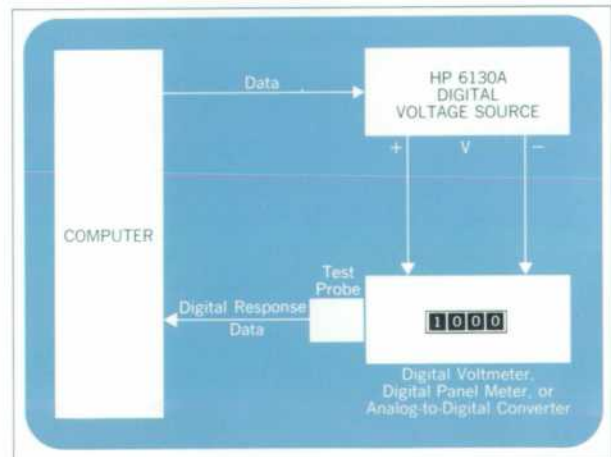

Fig. 4. Calibration

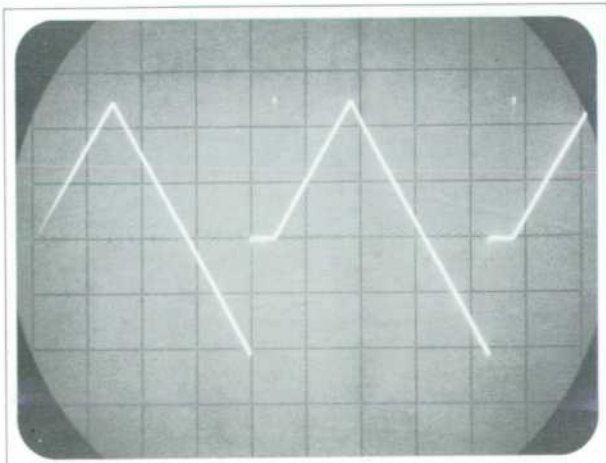

Fig. 2. Waveform Generation

(continued from page 13)

For complete safety, the output is automatically shorted when the unit is disconnected from the computer, and there are no harmful output transients when power is turned on or off.

Input Compatibility

Since the digital voltage source can be expected to have to operate with many different digital data sources, it has been designed to be easily modified to accommodate a variety of input-signal levels and polarities. Most special requirements can be met by modifying one, or at most two, plug-in circuit boards. Examples of input-circuit options are shown in Fig. 5.

To interface the digital voltage source to the Hewlett-Packard 2116A, 2115A, or 2114A computers, there is an accessory kit consisting of cables, connectors, and interface cards which plug into the computer.

Low-Power Version

The same digital circuitry that is used in the Model 6130A Digital Voltage Source is also used in a low-power unit, Model 6933A Digital-to-Analog Converter. In place of the power amplifier, this instrument has an integrated-circuit operational amplifier which provides an output of $\pm 10V$ at currents up to 10 mA. The operational amplifier is self-protected against short circuiting of its output, so the low-power instrument needs no current-limiting circuits. The low-power version can



Brett M. Nordgren

Brett Nordgren graduated from Purdue University in 1961 with a B.S. degree in engineering sciences. He joined the HP Harrison Division (then Harrison Laboratories) the same year. Among his design responsibilities have been the 6920A Meter Calibrator and a series of high-stability power supplies. Currently he is project leader for the 6130A Digital Voltage Source and the 6933A Digital-to-Analog Converter.

Brett has several patents pending on switching circuits and power supply designs. He is a member of Tau Beta Pi, he is active in the New Providence-Berkeley Heights, N.J. Jaycees, and he is working for his M.S. degree in electrical engineering at Stevens Institute of Technology.

make 50,000 voltage changes per second, five times as many as the Model 6130A.

Acknowledgments

I am grateful for the contributions of René Colen, who designed the digital circuits, Mark F. Eisenberg, who was responsible for the amplifier design, and Edward G. Varga, Jr., who did the mechanical design.

SPECIFICATIONS

HP Model 6130A Digital Voltage Source

DUAL RANGE DC OUTPUT:

- 10 to +10 V dc (1 mV increments) at 0 to 1 A.
- 50 to +50 V dc (10 mV increments) at 0 to 1 A.

CURRENT SINKING:

The ability to absorb energy from the load rather than supply it is defined as current sinking. This occurs when current is flowing into the positive terminal and out of the negative terminal. Model 6130A is capable of up to 500 mA current sinking.

CURRENT LIMIT:

20, 50, 70, 100, 200, 500, 700, or 1000 mA with an accuracy of 5%.

Current limit operates in both the source and sink modes.

LOAD REGULATION:

For a load current change equal to the current rating of the supply.

- 10-Volt Range: 0.2 mV.
- 50-Volt Range: 2 mV.

LINE REGULATION:

For a change in line voltage from 103.5 to 126.5 Vac.

- 10-Volt Range: 0.2 mV.
- 50-Volt Range: 2 mV.

RIPPLE AND NOISE:

Less than 1 mV p-p on 10 V range, 5 mV p-p on 50 V range at any line voltage and load condition within rating.

INPUT/OUTPUT DATA REQUIREMENTS:

BCD or binary format. The input/output coding and levels of the data for the Model 6130A are selected by the customer.

TEMPERATURE COEFFICIENT:

Output change per degree C change in ambient temperature following 30 minutes warmup.

- 10-Volt Range: Less than 100 $\mu V/^{\circ}C$.
- 50-Volt Range: Less than 500 $\mu V/^{\circ}C$.

ACCURACY AND RESOLUTION: At 25°C $\pm 10^{\circ}C$

- 50-Volt Range: 10 mV
- 10-Volt Range: 1 mV.

PROGRAMMING SPEED:

Time required to attain 99.9% of programmed value, using a resistive load.

- Voltage: -50 V to +50 V or +50 V to -50 V in less than 100 μs .
- Voltage Data Transfer Rate: Greater than 10,000 words/s.
- Current Limit: Less than 2 ms.
- Voltage Range: Less than 2 ms.

TRANSIENT RECOVERY TIME:

Less than 30 microseconds is required for output voltage recovery to within 0.1% of the range setting following a change in output current equal to the current rating of the supply.

PRICE: JO4-6130A. BCD format. Interfaces with HP computers

- 2114A, 2115A and 2116A. \$1500.
- JO5-6130A. Binary format. Interfaces with HP computers 2114A, 2115A and 2116A. \$1500.

HP Model 6933A Digital-to-Analog Converter

DC ANALOG OUTPUT:

- 10 to +10 V dc (1 mV increments) at 0 to 10 mA.

SHORT CIRCUIT PROOF

LINE REGULATION:

- Less than 200 μV for a change in line voltage from 103.5 to 126.5 Vac.

RIPPLE AND NOISE:

Less than 1 mV p-p at any line voltage and load condition within rating.

TRANSIENT RECOVERY TIME:

Less than 10 μs is required for output voltage recovery to within 10 mV of the programmed voltage following a change in output current of 10 mA.

TEMPERATURE COEFFICIENT: Less than 50 μV output change per degree C change in ambient temperature following 30 minutes warmup.

ACCURACY AND RESOLUTION: ± 1 mV at 25°C $\pm 15^{\circ}C$.

PROGRAMMING SPEED: Time required to attain 99.9% of programmed value.

- Output Voltage: -10 V to +10 V or +10 V to -10 V in less than 20 μs .
- Voltage Data Transfer Rate: Greater than 50,000 words/s.

INPUT/OUTPUT DATA REQUIREMENTS:

BCD or binary format. The input/output coding and levels of the data for Model 6933A are selected by the customer.

PRICE: JO2-6933A. BCD format. Interfaces with HP Computers

- 2114A, 2115A and 2116A. \$1200.
- JO4-6933A. Binary format. Interfaces with HP Computers 2114A, 2115A and 2116A. \$1200.

ACCESSORY AVAILABLE FOR MODELS 6130A AND 6933A:

POCKET PROGRAMMER: Model 14533A, \$97. Pocket-size switch box, suitable for manually programming all input functions of Models 6130A and 6933A.

MANUFACTURING DIVISION:

HP HARRISON DIVISION
100 Locust Avenue
Berkeley Heights, New Jersey 07922

HEWLETT-PACKARD JOURNAL JUNE 1968 Volume 19 • Number 10

TECHNICAL INFORMATION FROM THE LABORATORIES OF THE HEWLETT-PACKARD COMPANY PUBLISHED AT 1501 PAGE MILL ROAD, PALO ALTO, CALIFORNIA 94304

Editorial Staff: F. J. BURKHARDT, R. R. POLKMAN, D. EVEREDALE, R. H. ENYED, Art Director: R. A. ERICSSON