



# The World from a Dog's Point of View: A Review and Synthesis of Dog Cognition Research

Miles K. Bensky<sup>\*,1</sup>, Samuel D. Gosling<sup>\*</sup>, David L. Sinn<sup>\*,†</sup>

<sup>\*</sup>Department of Psychology, University of Texas at Austin, Austin, TX, USA

<sup>†</sup>School of Zoology, University of Tasmania, Hobart, TAS, Australia

<sup>1</sup>Corresponding author: E-mail: miles.bensky@utexas.edu

## Contents

1. Introduction	210
2. Literature Search Procedures	212
3. Major Trends in the Literature	213
4. What Do We Know?	303
4.1. Nonsocial Cognition	303
4.1.1. <i>Discrimination Learning</i>	303
4.1.2. <i>Object Permanence</i>	308
4.1.3. <i>Object Learning</i>	316
4.1.4. <i>Categorization/Inferential Reasoning</i>	318
4.1.5. <i>Object Manipulation</i>	325
4.1.6. <i>Quantitative Understanding</i>	331
4.1.7. <i>Spatial Cognition</i>	334
4.1.8. <i>Memory</i>	343
4.2. Generalizations and Recommendations for Future Studies on NonSocial Cognition	347
4.3. Social Cognition	349
4.3.1. <i>Response to Human Cues</i>	351
4.3.2. <i>Perspective Taking</i>	358
4.3.3. <i>Dog-to-Human Communication</i>	360
4.3.4. <i>Social Learning</i>	363
4.4. Generalizations and Recommendations for Future Studies on Social Cognition	378
5. Individual Differences in Cognition: Measurement, Cognitive Correlations, and Interactions with Personality	380
6. Summary and Conclusions	385
Acknowledgments	387
References	387



## 1. INTRODUCTION

As the first domesticated species, dogs have lived alongside humans for tens of thousands of years. Mitochondrial DNA evidence indicates that around 100,000 years ago dogs began to evolve away from the common ancestor of the modern-day wolf (Vila, 1997). The exact timing and extent of early hominid impact is not clear but it is likely this evolutionary divergence was facilitated by individual canines developing an increased threshold for being in the presence of humans, thus increasing the potential for interspecies' interaction (Coppinger & Coppinger, 2001). True domestication likely began around 14,000 years BP and by the time of the Ancient Egyptians (3000 years BP) numerous separate breeds of dogs had been established and were bred for a number of specific purposes (Galibert, Quignon, Hitte, & André, 2011). Ancient civilizations used dogs for different aspects of hunting, as guards, and for companionship; today dogs are still used for these same roles. In addition, humans now breed and train dogs for a multitude of additional tasks including helping the physically impaired, identifying disease, and helping to maintain public safety by finding drugs and explosives. From living on the outskirts of human settlements and taking advantage of our waste, to sleeping in our beds and eating directly off our tables, dogs occupy a unique ecological niche in the modern world.

The roles given to dogs (including companionship) are cognitively challenging. A dog's success depends on its ability to learn numerous environmental and social contingencies and apply these to a wide variety of contexts. Researchers have hypothesized that beyond changing canine morphology through domestication, human selection has also altered how dogs process information (Frank, 1980, 2011). Thus, an understanding of how dogs perceive elements of their environment and use knowledge of these elements to make decisions is a key to comprehending how they are able to take on the numerous roles humans give to them.

Over the last 20 years, there has been increasing interest in canine cognition. A number of topics drive this interest. First, the dog's interspecies communication abilities have been particularly fascinating to researchers, and investigations into the development of canine interspecies communication have led to theoretical models of how social cognition may have developed in early humans (e.g. Hare, 2007). Second, dogs have also been used as a model for understanding the development of human cognitive deficiencies. For example, researchers have used studies on Canine

Cognitive Dysfunction to further our understanding of Alzheimer's disease in humans (Head, Cotman, & Milgram, 2000). Third, the relative ease of accessing subjects has led to dogs being increasingly seen as viable subjects for researching a number of fundamental areas of animal behavior such as memory (e.g. Fujita, Morisaki, Takaoka, Maeda, & Hori, 2012), foraging behavior (e.g. Fiset, 2007), and social learning (e.g. Mersmann, Tomasello, Call, Kaminski, & Taborsky, 2011). Thus, beyond learning more about dog cognition specifically, researchers are increasingly utilizing dogs as a model species to provide insight into cognition in both human and other non-human species. Fourth, the dog's prevalence in human society presents unique opportunities for applied research related to cognition in such areas as working-dog performance (e.g. Gazit, Goldblatt, & Terkel, 2005a) and animal welfare (e.g. Burman et al., 2011). Finally, a large public interest in understanding "man's best friend" has also contributed toward making the dog an attractive research subject (Morell, 2009).

Research on canine cognition is being done in a wide variety of scientific disciplines, including ethology, evolutionary anthropology, behavioral analytics, developmental psychology, and neuroscience. As a consequence, research efforts in different disciplines have often followed independent paths. Each of these discipline-bound studies is valuable, but each provides only a relatively narrow glimpse of the overall cognitive abilities of dogs. This fragmented approach also draws attention away from how different biological, ecological, and evolutionary aspects of cognition may interact with one another to aid the dog's ability to make decisions and solve problems. To date, there has been little effort to review and summarize what these numerous studies have taught us about canine cognition as a whole (previous reviews have focused on subfacets of canine cognition, predominantly social cognition: e.g. Kubinyi, Pongrácz, & Miklósi, 2009; Topál, Miklósi, et al., 2009; Udell & Wynne, 2008; though see Miklósi, 2008). Thus, the goal of the present paper is to provide the most comprehensive review to date of previous research on dog cognition.

Specifically, we (1) identify major trends in the literature, in terms of the characteristics of the dog populations studied and the areas of cognition researched, (2) identify the major topics of research in the dog cognition, (3) summarize the previous findings within each of these topics, and (4) make suggestions for future cognition research. Finally, we will draw the findings together to offer six broad conclusions about the field and identify questions that remain to be addressed. Thus, this article is meant to serve as a centralized resource for those interested in the growing field of dog

cognition and to help guide future work in canine research and training practices.



## 2. LITERATURE SEARCH PROCEDURES

Our aim was to capture all previous relevant research. Our literature-search procedures consisted of two broad steps: (1) generating pools of potentially relevant research articles and then (2) selecting those that were pertinent. To identify the maximum number of potentially relevant articles, we created a 3 (“dog” or “canine” or “puppy”) × 2 (“cognition” or “learning”) matrix of keyword search terms and used all combinations of these terms as input into the PsychInfo, Biosis, and Web of Science databases. All 18 searches were conducted by December 31, 2012.

This broad search strategy uncovered hundreds of articles in each search, many of which were clearly not within the scope of this review. For example, there were a number of studies investigating human language learning, which incorporated the word “dog” in their protocols. So, an initial selection process was conducted by using titles and abstracts to discard articles that were clearly not relevant to either animal cognition or canine research. This process was conducted for each search.

Next, a second selection cycle was conducted to remove articles that may have been related to the topics of canine research or cognition but still were clearly not within the scope of this review. First, articles were not retained if dogs were not used as subjects. For example, one excluded study aimed to measure how birds (*Nucifraga columbiana*) respond to human cues using an experimental learning paradigm previously used with dogs (Tornick, Gibson, Kispert, & Wilkinson, 2011). There were also a number of excluded articles that involved canine research, but did not involve cognition. For example, an article by Wan, Kubinyi, Miklósi, and Champagne (2009) was initially flagged as potentially relevant but its aim was to measure human cross-cultural differences in dog keeping practices, dog behavior, and temperament so it was not retained in the final set of target articles. Finally, our search criteria initially flagged a number of articles and book chapters (e.g. Wynne, 2004) that addressed different aspects of animal cognition and tangentially mentioned dogs in their discussion. However, dogs were not the central foci of these reports so they were not retained for the review.

It was clear that there remained a sizeable amount of literature investigating dogs’ olfactory-detection abilities as a demonstration of job competence that did not contribute novel information regarding cognition.

Therefore, we specifically excluded articles demonstrating olfactory-based detection competence if their primary focus was on providing empirical verification of the use of dogs for a specific detection job (e.g. Brooks, Oi, & Koehler, 2003; Cablk, Sagebiel, Heaton, & Valentin, 2008; Hawk & Conley, 1984; Lorenzo et al., 2003; McCulloch et al., 2006; Pfister, Koehler, & Pereira, 2008; Willis et al., 2004). We did, however, include olfactory-based detection studies that measured behavioral responses indicative of learning (e.g. Jezierski, Walczak, & Górecka, 2008; Lit & Crawford, 2006), compared olfactory behavior with other sensory modalities (e.g. Gazit & Terkel, 2003), and those that evaluated the impact of ontogeny on job-related behaviors (e.g. Slabbert & Rasa, 1997). For a review of olfactory-based detection competence studies using working-dogs see Helton (2009) and Moser and McCulloch (2010).

Inspection of the references cited in the selected articles sometimes revealed studies that had not been identified in the initial search. Therefore, each time a new article was identified, we searched its references for other potentially relevant articles. Repeated use of this strategy eventually led to redundancies.

These search procedures identified 285 publications, which are shown in Table 5.1. Of course although we took great effort to identify all relevant articles, no search procedure is flawless. Therefore it is possible that our review procedures missed some relevant articles. However, we are optimistic that even if some articles have been missed, our review contains multiple representatives of each of the various subareas of cognition on which there has been empirical research. As a result, we believe the set of articles assembled here represents the most comprehensive review of the subject to date.



---

### **3. MAJOR TRENDS IN THE LITERATURE**

In order to help organize the literature and identify some major trends in our selected articles we first categorized each article based on a number of characteristics (Table 5.1). One way to begin to organize the previous dog cognition research is to separate findings between nonsocial (or physical) and social cognition studies. Here, we classified studies as “nonsocial” if they focused on/manipulated how animals perceive and process information about, or interact with, inanimate elements of their environment. Studies were classified as “social” if the primary focus was on how animals encoded information about social companions (be it a conspecific or interspecific relationship), and utilized this information to

**Table 5.1** Literature search results. Each article is categorized based on the subcategories of canine cognition it primarily investigated or discussed. These subcategories are not mutually exclusive so several articles have been categorized in up to two subcategories. The types of subcategories related to nonsocial cognition are: discrimination learning (DL), object permanence (OP), object learning (OL), categorization/inferential reasoning (C/I), object manipulation (OM), quantitative understanding (QU), spatial cognition (Sp.), memory (M), nonsocial multiple (N-M; more than two nonsocial categories), or nonsocial other (N-O; subject does not fit within one of the major categories reviewed). The subcategories related to social cognition are: response to human cues (S-R), perspective taking (S-P),

Authors	Year	Article title	Article designation			Populations tested		
			Article type	First category	Second category	Pets 182	Laboratory 48	Working dogs 25
Thorndike	1911	Animal intelligence: An experimental study of the associative processes in animals.	E	OM	S-SL			
Shepherd	1915	Tests on adaptive intelligence in dogs and cats, as compared with adaptive intelligence in rhesus monkeys.	E	OM				
Shepherd	1919	On sound discrimination in dogs.	E	DL				
Clarke et al.	1951	Individual differences in dogs: Preliminary report on the effects of early experience.	E	Sp.			•	
Thompson & Heron	1954	The effects of restricting early experience on the problem-solving capacity of dogs.	E	Sp.	M		•	
Wyrwicka	1959	Studies on detour behaviour.	E	Sp.			•	
Scott & Fuller	1965	Genetics and the social behavior of the dog.	E	N-M			•	

dog-to-human communication (S-C), social learning (S-SL), social multiple (S-M; more than two social categories), or social other (N-O; subject does not fit within one of the major categories reviewed). Article types reviewed were as follows: empirical studies (E), commentaries (C), or review articles (R). There are a few cases in which a commentary (C/E) or review article (R/E) also included original empirical research. Counts for each category (i.e. number of studies as labeled as including that dog population, sensory modality, or age group) are shown below the group labels at the top of the table. Studies are first sorted by chronological year; within each year studies are then sorted by first subcategory, then article type, and then the first author's name.

Sensory modalities focused on								Age groups		Age effects
Other	Unspecified	Visual	Olfactory	Auditory	Tactile	Taste	Unclear	<1 year	>1 year	
17	5	187	22	51	31	5	55	34	222	32
	•	•			•				•	
	•	•			•				•	
	•			•					•	
							•	•		
							•	•	•	
							•	•		
		•	•		•			•		

Continued

Table 5.1—Cont'd

Authors	Year	Article title	Article designation			Populations tested		
			Article type	First category	Second category	Pets 182	Laboratory 48	Working dogs 25
Fuller	1966	Transitory effects of experiential deprivation upon reversal learning in dogs.	E	DL			•	
Bacon & Stanley	1968	Avoidance learning in neonatal dogs.	E	DL			•	
Bacon & Stanley	1970	Reversal learning in neonatal dogs.	E	DL			•	
Stanley, Bacon & Fehr	1970	Discriminated instrumental learning in neonatal dogs.	E	DL			•	
Brown & Sołtysik	1971	Four-pair same-different differentiation and transient memory in dogs.	E	DL	M		•	
Pietrzykowska & Sołtysik	1975b	Transfer of the “same-different” differentiation task in dogs.	E	DL	M		•	
Pietrzykowska & Sołtysik	1975a	A failure to train the “same different” differentiation of photic stimuli in dogs.	E	DL	M		•	
Adler & Adler	1977	Ontogeny of observational learning in the dog ( <i>Canis familiaris</i> ).	E	S-SL				
Frank	1980	Evolution of canine information processing under condition of natural and artificial selection.	R	N-M		NA	NA	NA



Sensory modalities focused on								Age groups		Age effects
Other	Unspecified	Visual	Olfactory	Auditory	Tactile	Taste	Unclear	<1 year	>1 year	
17	5	187	22	51	31	5	55	34	222	32
		•						•		
					•			•		
					•			•		
				•				Unk	Unk	
		•		•					•	
		•							•	
•		•			•			•		•
NA	NA	NA	NA	NA	NA	NA	NA	NA	NA	NA

Continued

Table 5.1—Cont'd

Authors	Year	Article title	Article designation			Populations tested		
			Article type	First category	Second category	Pets 182	Laboratory 48	Working dogs 25
Triana & Pasnak	1981	Object permanence in cats and dogs.	E	OP		•		
Frank & Frank	1983	Inhibition training in wolves ( <i>Canis lupus</i> ) and dogs ( <i>Canis familiaris</i> ).	E	N-O			•	
Chapuis et al.	1983	Dissociation of mechanisms involved in dogs' oriented displacements.	E	Sp.				
Frank & Frank	1985	Comparative manipulation-test performance in ten-week-old wolves and Alaskan malamutes: A Piagetian interpretation.	E	OM			•	
Chapuis & Varlet	1987	Short cuts by dogs in natural surroundings.	E	Sp.				
Pasnak et al.	1988	Assessment of stage 6 object permanence.	E	OP		•		
Frank, Frank, Hasselbach, & Littleton	1989	Motivation and insight in wolf ( <i>Canis lupus</i> ) and Alaskan malamute ( <i>Canis familiaris</i> ): Visual discrimination learning.	E	DL			•	
McConnell	1990	Acoustic structure and receiver response in domestic dogs, <i>Canis familiaris</i> .	E	DL			•	

Sensory modalities focused on							Age groups		Age effects	
Other	Unspecified	Visual	Olfactory	Auditory	Tactile	Taste	Unclear	<1 year		>1 year
17	5	187	22	51	31	5	55	34	222	32
•		•							•	
					•			•		
•		•						•		
		•			•			•		
	•	•					•	•		
•		•						Unk	Unk	
		•						•		
				•				•		

Continued

Table 5.1—Cont'd

Authors	Year	Article title	Article designation			Populations tested		
			Article type	First category	Second category	Pets 182	Laboratory 48	Working dogs 25
Steen & Wilsson	1990	How do dogs determine the direction of tracks?	E	DL				•
Gagnon & Doré	1992	Search behavior in various breeds of adult dogs ( <i>Canis familiaris</i> ): Object permanence and olfactory cues.	E	OP				
Fabrigoule & Sagave	1992	Reorganization of cues and path organization in dogs ( <i>Canis familiaris</i> ).	E	Sp.	M			
Gagnon & Doré	1993	Search behavior of dogs ( <i>Canis familiaris</i> ) in invisible displacement problems.	E	OP		•		
Milgram et al.	1994	Cognitive functions and aging in the dog: Acquisition of nonspatial visual tasks.	E	DL			•	
Gagnon & Doré	1994	Cross-sectional study of object permanence in domestic pups ( <i>Canis familiaris</i> ).	E	OP		•		
Millot	1994	Olfactory and visual cues in the interaction systems between dogs and children.	E	S-R		•		

Sensory modalities focused on								Age groups		Age effects
Other	Unspecified	Visual	Olfactory	Auditory	Tactile	Taste	Unclear	<1 year	>1 year	
17	5	187	22	51	31	5	55	34	222	32
			•						•	
•		•	•						•	
	•						•	•		
		•							•	
		•							•	•
		•						•		•
		•	•						•	

Continued

Table 5.1—Cont'd

Authors	Year	Article title	Article designation			Populations tested		
			Article type	First category	Second category	Pets 182	Laboratory 48	Working dogs 25
Head et al.	1995	Spatial learning and memory as a function of age in the dog.	E	DL	M		•	
Doré et al.	1996	Search behavior in cats and dogs: Interspecific differences in working memory and spatial cognition.	E	OP	M	•		
Kowalska	1997	The method of training dogs in auditory recognition memory tasks with trial-unique stimuli.	E	DL	M		•	
Schoon	1997	Scent identification by dogs ( <i>Canis familiaris</i> ): A new experimental design.	E	DL				•
Topál et al.	1997	Dog-human relationship affects problem-solving behavior in the dog.	E	OM	S-C	•		
Slabbert & Rasa	1997	Observational learning of an acquired maternal behaviour pattern by working dog pups: An alternative training method?	E	S-SL				•
Dumas	1998	Figurative and spatial information and search behaviour in dogs ( <i>Canis familiaris</i> ).	E	DL		•		

Sensory modalities focused on								Age groups		Age effects
Other	Unspecified	Visual	Olfactory	Auditory	Tactile	Taste	Unclear	<1 year	>1 year	
17	5	187	22	51	31	5	55	34	222	32
		•							•	•
•		•							•	
				•					•	
			•						•	
					•		•		•	
							•	•		
		•							•	

Continued

Table 5.1—Cont'd

Authors	Year	Article title	Article designation			Populations tested		
			Article type	First category	Second category	Pets	Laboratory	Working dogs
						182	48	25
Head et al.	1998	Visual-discrimination learning and $\beta$ -amyloid accumulation in the dog.	E	DL	M		•	
Kuśmierek & Kowalska	1998	Effect of experimental setting on learning and performance of auditory delayed matching-to-sample task in dogs.	E	DL			•	
Hare et al.	1998	Communication of food location between human and dog ( <i>Canis familiaris</i> ).	E	S-M		•		
Miklósi et al.	1998	Use of experimenter-given cues in dogs.	E	S-R		•		•
Séguinot et al.	1998	Path integration in dogs.	E	Sp.		•		
Milgram et al.	1999	Landmark discrimination learning in the dogs.	E	DL	M		•	
Hare & Tomasello	1999	Domestic dogs ( <i>Canis familiaris</i> ) use human and conspecific social cues to locate hidden food.	E	S-R		•		
Milgram et al.	2000	Oral administration of adrafinil improves discrimination learning in aged beagle dogs.	E	DL			•	



Sensory modalities focused on							Age groups			Age effects
Other	Unspecified	Visual	Olfactory	Auditory	Tactile	Taste	Unclear	<1 year	>1 year	
17	5	187	22	51	31	5	55	34	222	32
		•							•	
				•					•	
		•							•	
		•					•		•	
		•							•	•
		•							•	
		•							•	

Continued

Table 5.1—Cont'd

Authors	Year	Article title	Article designation			Populations tested		
			Article type	First category	Second category	Pets 182	Laboratory 48	Working dogs 25
Adams, Chan, Callahan, Siwak, et al.	2000	Use of a delayed nonmatching to position task to model age-dependent cognitive decline in the dog.	E	M	DL		•	
Callahan, Ikeda-Douglas, Head, Cotman, & Milgram	2000	Development of a protocol for studying object recognition memory in the dog.	E	M	DL		•	
Adams et al.	2000a	The canine as a model of human cognitive aging: Recent developments.	R	M	DL	NA	NA	NA
Miklósi et al.	2000	Intentional behavior in dog-human communication: An experimental analysis of “showing” behaviour in the dog.	E	S-C		•		
Agnetta et al.	2000	Cues to food location that domestic dogs ( <i>Canis familiaris</i> ) of different ages do and do not use.	E	S-R		•		
McKinley & Sambrook	2000	Use of human-given cues by domestic dogs ( <i>Canis familiaris</i> ) and horses ( <i>Equus caballus</i> ).	E	S-R		•		•

Sensory modalities focused on								Age groups		Age effects
Other	Unspecified	Visual	Olfactory	Auditory	Tactile	Taste	Unclear	<1 year	>1 year	
17	5	187	22	51	31	5	55	34	222	32
		•							•	•
		•							•	•
NA	NA	NA	NA	NA	NA	NA	NA	NA	NA	NA
							•		•	
		•						•	•	•
		•							•	

Continued

Table 5.1—*Cont'd*

Authors	Year	Article title	Article designation			Populations tested		
			Article type	First category	Second category	Pets	Laboratory	Working dogs
						182	48	25
Fiset <i>et al.</i>	2000	Spatial encoding of hidden objects in dogs ( <i>Canis familiaris</i> ).	E	Sp.		•		
Watson <i>et al.</i>	2001	Distinguishing logic versus association in the solution of an invisible displacement task by children and dogs: Using negation of disjunction.	E	OP		•		
Soproni <i>et al.</i>	2001	Comprehension of human communicative signs in pet dogs.	E	S-R		•		
Pongrácz <i>et al.</i>	2001	Social learning in dogs: The effect of a human demonstrator on the performance of dogs ( <i>Canis familiaris</i> ) in a detour task.	E	S-SL	Sp.	•		
Chan <i>et al.</i>	2002	Visuospatial impairments in aged canines ( <i>Canine familiaris</i> ): The role of cognitive-behavioural flexibility.	E	DL	M		•	
Kuśmierek & Kowalska	2002	Effect of sound source position on learning and performance of auditory delayed matching-to-sample task in dogs.	E	DL	M		•	

Sensory modalities focused on								Age groups		Age effects
Other	Unspecified	Visual	Olfactory	Auditory	Tactile	Taste	Unclear	<1 year	>1 year	
17	5	187	22	51	31	5	55	34	222	32
		•							•	
		•							•	
		•							•	
		•					•		•	
		•							•	
				•					•	

Continued

Table 5.1—Cont'd

Authors	Year	Article title	Article designation			Populations tested		
			Article type	First category	Second category	Pets 182	Laboratory 48	Working dogs 25
Milgram <i>et al.</i>	2002	Landmark discrimination learning in the dog: Effects of age, an antioxidant fortified food, and cognitive strategy.	E	DL	Sp.		•	
Williams & Johnston	2002	Training and maintaining the performance of dogs ( <i>Canis familiaris</i> ) on an increasing number of odor discriminations in a controlled setting.	E	DL			•	
West & Young	2002	Do domestic dogs show any evidence of being able to count?	E	QU		•		
Hare <i>et al.</i>	2002	The domestication of social cognition in dogs.	E	S-R	M	•		
Soproni <i>et al.</i>	2002	Dogs' ( <i>Canis familiaris</i> ) responsiveness to human pointing gestures.	E	S-R		•		
Gazit & Terkel	2003	Domination of olfaction over vision in explosives detection by dogs.	E	DL				•
Milgram	2003	Cognitive experience and its effect on age-dependent cognitive decline in beagle dogs.	E	DL			•	

Sensory modalities focused on							Age groups			
Other	Unspecified	Visual	Olfactory	Auditory	Tactile	Taste	Unclear	<1 year	>1 year	Age effects
17	5	187	22	51	31	5	55	34	222	32
		•							•	•
			•						•	
		•							•	
•		•						•	•	•
		•							•	
		•	•						•	
		•							•	•

*Continued*

Table 5.1—Cont'd

Authors	Year	Article title	Article designation			Populations tested		
			Article type	First category	Second category	Pets 182	Laboratory 48	Working dogs 25
Nippak et al.	2003	Response latency in <i>Canis familiaris</i> : Mental ability or mental strategy?	E	DL	M		•	
Tapp, Siwak, Estrada, Head, et al.	2003	Size and reversal learning in the beagle dog as a measure of executive function and inhibitory control in aging.	E	DL			•	
Wells & Hepper	2003	Directional tracking in the domestic dog, <i>Canis familiaris</i> .	E	DL				•
Fiset et al.	2003	Duration of dogs' ( <i>Canis familiaris</i> ) working memory in search for disappearing objects.	E	M	OP	•		
Tapp, Siwak, Estrada, Holowachuk, et al.	2003	Effects of age on measures of complex working memory span in the beagle dog ( <i>Canis familiaris</i> ) using two versions of a spatial list learning paradigm.	E	M	DL		•	
Osthaus et al.	2003	Can dogs defy gravity? A comparison with the human infant and a nonhuman primate.	E	OL		•		



Sensory modalities focused on								Age groups		Age effects
Other	Unspecified	Visual	Olfactory	Auditory	Tactile	Taste	Unclear	<1 year	>1 year	
17	5	187	22	51	31	5	55	34	222	32
		•							•	•
		•							•	•
		•	•						•	•
		•							•	
		•							•	•
		•							•	

Continued

Table 5.1—Cont'd

Authors	Year	Article title	Article designation			Populations tested		
			Article type	First category	Second category	Pets 182	Laboratory 48	Working dogs 25
Miklósi <i>et al.</i>	2003	A simple reason for a big difference: Wolves do not look back at humans but dogs do.	E	S-C		•		
Call <i>et al.</i>	2003	Domestic dogs ( <i>Canis familiaris</i> ) are sensitive to the attentional state of humans.	E	S-P		•		
Cooper <i>et al.</i>	2003	Clever hounds: Social cognition in the domestic dog ( <i>Canis familiaris</i> ).	R	S-P	QU	NA	NA	NA
Pongrácz, Miklósi, Dóka, & Csáni	2003	Successful application of video-projected human images for signaling to dogs.	E	S-R		•		
Szetei <i>et al.</i>	2003	When dogs seem to lose their nose: An investigation on the use of visual and olfactory cues in communicative context between dog and owner.	E	S-R		•		
Kubinyi, Miklósi, <i>et al.</i>	2003	Social mimetic behaviour and social anticipation in dogs: Preliminary results.	E	S-SL		•		

Sensory modalities focused on								Age groups		Age effects
Other	Unspecified	Visual	Olfactory	Auditory	Tactile	Taste	Unclear	<1 year	>1 year	
17	5	187	22	51	31	5	55	34	222	32
							•	•		
		•							•	
NA	NA	NA	NA	NA	NA	NA	NA	NA	NA	NA
		•							•	
		•	•						•	
							•		•	

Continued

Table 5.1—Cont'd

Authors	Year	Article title	Article designation			Populations tested		
			Article type	First category	Second category	Pets 182	Laboratory 48	Working dogs
								25
Kubinyi, Topál, et al.	2003	Dogs ( <i>Canis familiaris</i> ) learn from their owner via observation in a manipulation task.	E	S-SL		•		
McKinley & Young	2003	The efficacy of the model-rival method when compared with operant conditioning for training domestic dogs to perform a retrieval-selection task.	E	S-SL	C/I	•		
Pongrácz, Miklósi, Timár- Geng, et al.	2003	Preference for copying unambiguous demonstrations in dogs.	E	S-SL	Sp.	•		
Pongrácz, Miklósi, Kubinyi, et al.	2003	Interaction between individual experience and social learning in dogs.	E	Sp.	S-SL	•		
Bloom	2004	Can a dog learn a word?	C	C/I		NA	NA	NA
Fischer et al.	2004	A pluralistic account of word learning.	C	C/I		NA	NA	NA
Markman & Abelev	2004	Word learning in dogs?	C	C/I		NA	NA	NA
Kaminski et al.	2004	Word learning in a domestic dog: Evidence for “fast mapping.”	E	C/I		•		

Sensory modalities focused on							Age groups			Age effects
Other	Unspecified	Visual	Olfactory	Auditory	Tactile	Taste	Unclear	<1 year	>1 year	
17	5	187	22	51	31	5	55	34	222	32
		•			•				•	
		•		•					•	
		•					•		•	
		•					•		•	
NA	NA	NA	NA	NA	NA	NA	NA	NA	NA	NA
NA	NA	NA	NA	NA	NA	NA	NA	NA	NA	NA
NA	NA	NA	NA	NA	NA	NA	NA	NA	NA	NA
		•		•					•	

Continued

Table 5.1—Cont'd

Authors	Year	Article title	Article designation			Populations tested		
			Article type	First category	Second category	Pets 182	Laboratory 48	Working dogs 25
Araujo et al.	2004	Dose-specific effects of scopolamine on canine cognition: Impairment of visuospatial memory, but not visuospatial discrimination.	E	DL	M		•	
Tapp et al.	2004	Concept abstraction in the aging dog: Development of a protocol using successive discrimination and size concept tasks.	E	DL			•	
Collier-Baker et al.	2004	Do dogs ( <i>Canis familiaris</i> ) understand invisible displacement?	E	OP		•		
Miklósi, Topál, & Csányi	2004	Comparative social cognition: What can dogs teach us?	R	S-M		NA	NA	NA
Bräuer et al.	2004	Visual perspective taking in dogs ( <i>Canis familiaris</i> ) in the presence of barriers.	E	S-P		•		
Gácsi et al.	2004	Are readers of our face readers of our minds? dogs ( <i>Canis familiaris</i> ) show situation-dependent recognition of human's attention.	E	S-P		•		

Sensory modalities focused on								Age groups		Age effects
Other	Unspecified	Visual	Olfactory	Auditory	Tactile	Taste	Unclear	<1 year	>1 year	
17	5	187	22	51	31	5	55	34	222	32
		•							•	
		•							•	•
		•							•	
NA	NA	NA	NA	NA	NA	NA	NA	NA	NA	NA
		•							•	
		•							•	

Continued

Table 5.1—Cont'd

Authors	Year	Article title	Article designation			Populations tested		
			Article type	First category	Second category	Pets	Laboratory	Working dogs
						182	48	25
Virányi <i>et al.</i>	2004	Dogs respond appropriately to cues of humans' attentional focus.	E	S-P		•		
Pongrácz <i>et al.</i>	2004	Verbal attention getting as a key factors in social learning between dog ( <i>Canis familiaris</i> ) and human.	E	S-SL		•		
Cattet & Etienne	2004	Blindfolded dogs relocate a target through path integration.	E	Sp.		•		
Christie <i>et al.</i>	2005	A comparison of egocentric and allocentric age-dependent spatial learning in the beagle dog.	E	DL	Sp.		•	
Fukuzawa, Mills, & Cooper	2005a	The effect of human command phonetic characteristics on auditory cognition in dogs ( <i>Canis familiaris</i> ).	E	DL		•		
Fukuzawa, Mills & Cooper <i>et al.</i>	2005b	More than just a word: Nonsemantic command variables affect obedience in the domestic dog ( <i>Canis familiaris</i> ).	E	DL	S-P	•		



Sensory modalities focused on							Age groups			Age effects
Other	Unspecified	Visual	Olfactory	Auditory	Tactile	Taste	Unclear	<1 year	>1 year	
17	5	187	22	51	31	5	55	34	222	32
		•							•	
		•	•	•					•	
		•			•				•	
		•							•	•
				•					•	
		•		•					•	

Continued

Table 5.1—Cont'd

Authors	Year	Article title	Article designation			Populations tested		
			Article type	First category	Second category	Pets 182	Laboratory 48	Working dogs 25
Hepper & wells	2005	How many footsteps do dogs need to determine the direction of an odour trails?	E	DL				•
Nippak & Milgram	2005	An investigation of the relationship between response latency across several cognitive tasks in the beagle dog.	E	DL			•	
Gazit et al.	2005b	The role of context specificity in learning: The effects of training context on explosives detection in dogs.	E	M				•
Gazit et al.	2005a	Formation of an olfactory search image for explosive odors in sniffer dogs.	E	OL	M			•
Osthaus et al.	2005	Dogs ( <i>Canis lupus familiaris</i> ) fail to show understanding of means-end connections in a string-pulling task.	E	OM		•		
Gácsi et al.	2005	Species-specific differences and similarities in the behavior of hand-raised dog and wolf pups in social situations with humans.	E	S-C			•	

Sensory modalities focused on								Age groups		Age effects
Other	Unspecified	Visual	Olfactory	Auditory	Tactile	Taste	Unclear	<1 year	>1 year	
17	5	187	22	51	31	5	55	34	222	32
		•	•						•	
		•							•	
		•	•						•	
			•						•	
		•			•				•	
							•	•		•

Continued

Table 5.1—Cont'd

Authors	Year	Article title	Article designation			Populations tested		
			Article type	First category	Second category	Pets 182	Laboratory 48	Working dogs 25
Miklósi, Pongrácz, Lakatos, Topál, & Csány	2005	A comparative study of the use of visual communicative signals in interactions between dogs ( <i>Canis familiaris</i> ) and humans and cats ( <i>Felis catus</i> ) and humans.	E	S-R	S-C	•		
Vas, Topál, Gácsi, Miklósi, & Csányi	2005	A friend or an enemy? dogs' reaction to an unfamiliar person showing behavioural cues of threat and friendliness at different times.	E	S-R		•		
Hare & Tomasello	2005	Human-like social skills in dogs.	R	S-R		NA	NA	NA
Pongrácz, Miklósi, Vida, & Csányi	2005	The pet dogs' ability for learning from a human demonstrator in a detour task is independent from the breed and age.	E	S-SL		•		
Hepper & Wells	2006	Perinatal olfactory learning in the domestic dog.	E	DL		•		
Lit & Crawford	2006	Effects of training paradigms on search dog performance.	E	DL				•

Sensory modalities focused on								Age groups		Age effects
Other	Unspecified	Visual	Olfactory	Auditory	Tactile	Taste	Unclear	<1 year	>1 year	
17	5	187	22	51	31	5	55	34	222	32
		•					•		•	
		•		•					•	
NA	NA	NA	NA	NA	NA	NA	NA	NA	NA	NA
		•					•	•	•	•
			•					•		
			•						•	

Continued

Table 5.1—Cont'd

Authors	Year	Article title	Article designation			Populations tested		
			Article type	First category	Second category	Pets 182	Laboratory 48	Working dogs 25
Nippak, Ikeda-Douglas, & Milgram	2006	Extensive spatial training does not negate age differences in response latency.	E	DL	M		•	
Wells & Hepper	2006	Prenatal olfactory learning in the domestic dog.	E	DL		•		
Rooney & Bradshaw	2006	Social cognition in the domestic dog: Behaviour of spectators toward participants in interspecific games.	E	S-O			•	
Schwab & Huber	2006	Obey or not obey? dogs ( <i>Canis familiaris</i> ) behave differently in response to attentional states of their owners.	E	S-P		•		
Topál, Erdőhegyi, et al.	2006	Mindreading in a dog: An adaptation of a primate “mental attribution” study.	E	S-P	S-C			•
Virányi et al.	2006	A nonverbal test of knowledge attribution: A comparative study on dogs and children.	E	S-P	S-C	•		
Bräuer et al.	2006	Making inferences about the location of hidden food. Social dog, causal ape.	E	S-R	OL	•		

Sensory modalities focused on								Age groups		Age effects
Other	Unspecified	Visual	Olfactory	Auditory	Tactile	Taste	Unclear	<1 year	>1 year	
17	5	187	22	51	31	5	55	34	222	32
		•							•	•
			•					•		
							•		•	
		•							•	
							•		•	
							•		•	
		•	•	•					•	

Continued

Table 5.1—Cont'd

Authors	Year	Article title	Article designation			Populations tested		
			Article type	First category	Second category	Pets 182	Laboratory 48	Working dogs 25
Riedel, Buttelmann, Call, & Tomasello	2006	Domestic dogs ( <i>Canis familiaris</i> ) use a physical marker to locate hidden food.	E	S-R	DL	•		
Miklósi & Soproni	2006	A comparative analysis of animals' understanding of the human pointing gesture.	R	S-R		NA	NA	NA
Topál, Byrne, et al.	2006	Reproducing human actions and action sequences: "Do as I do!" in a dog.	E	S-SL				•
Dumas & Pagé	2006	Strategy planning in dogs ( <i>Canis familiaris</i> ) in a progressive elimination task.	E	Sp.	M	•		
Fiset et al.	2006	Egocentric search for disappearing objects in domestic dogs: Evidence for a geometric hypothesis of direction.	E	Sp.		•		
Erdőhegyi et al.	2007	Dog-logic: Inferential reasoning in a two-way choice task and its restricted use.	E	N-O	S-R	•		



Sensory modalities focused on							Age groups			Age effects
Other	Unspecified	Visual	Olfactory	Auditory	Tactile	Taste	Unclear	<1 year	>1 year	
17	5	187	22	51	31	5	55	34	222	32
		•							•	
NA	NA	NA	NA	NA	NA	NA	NA	NA	NA	NA
		•			•				•	
		•							•	
		•							•	
		•							•	

*Continued*

Table 5.1—Cont'd

Authors	Year	Article title	Article designation			Populations tested		
			Article type	First category	Second category	Pets 182	Laboratory 48	Working dogs 25
Adachi et al.	2007	Dogs recall their owner's face upon hearing the owner's voice.	E	OL		•		
Fiset & LeBlanc	2007	Invisible displacement understanding in domestic dogs ( <i>Canis familiaris</i> ): The role of visual cues in search behavior.	E	OP		•		
Ward & Smuts	2007	Quantity-based judgments in the domestic dog ( <i>Canis lupus familiaris</i> ).	E	QU		•		
Kubinyi et al.	2007	Comparative social cognition: From wolf and dog to humans.	R	S-M		NA	NA	NA
Lakatos, Dóka, & Miklósi	2007	The role of visual cues in the comprehension of the human pointing signals in dogs.	E	S-R		•		
Hare	2007	From nonhuman to human mind: What changed and why?	R	S-R		NA	NA	NA
Miklósi, Topál, & Csányi	2007	Big thoughts in small brains? dogs as a model for understanding human social cognition.	R	S-R	S-C	NA	NA	NA

Sensory modalities focused on							Age groups			Age effects
Other	Unspecified	Visual	Olfactory	Auditory	Tactile	Taste	Unclear	<1 year	>1 year	
17	5	187	22	51	31	5	55	34	222	32
		•		•					•	
		•							•	
		•							•	
NA	NA	NA	NA	NA	NA	NA	NA	NA	NA	NA
		•							•	
NA	NA	NA	NA	NA	NA	NA	NA	NA	NA	NA
NA	NA	NA	NA	NA	NA	NA	NA	NA	NA	NA

Continued

Table 5.1—Cont'd

Authors	Year	Article title	Article designation			Populations tested		
			Article type	First category	Second category	Pets 182	Laboratory 48	Working dogs 25
Range et al.	2007	Selective imitation in domestic dogs.	E	S-SL		•		
Fiset	2007	Landmark-based search memory in the domestic dog ( <i>Canis familiaris</i> ).	E	Sp.		•		
Fiset et al.	2007	Spatial memory of domestic dogs ( <i>Canis familiaris</i> ) for hidden objects in a detour task.	E	Sp.		•		
Aust et al.	2008	Inferential reasoning by exclusion in pigeons, dogs, and humans.	E	C/I		•		
Kaulfuss & Mills	2008	Neophilia in domestic dogs ( <i>Canis familiaris</i> ) and its implication for studies of dog cognition.	E	C/I		•		
Range et al.	2008	Visual categorization of natural stimuli by domestic dogs.	E	C/I		•		
Rossi & Ades	2008	A dog at the keyboard: Using arbitrary signs to communicate requests.	E	C/I	S-C	•		
Jeziarski et al.	2008	Information-seeking behaviour of sniffer dogs during match-to-sample training in the scent lineup.	E	DL				•

Sensory modalities focused on							Age groups		Age effects	
Other	Unspecified	Visual	Olfactory	Auditory	Tactile	Taste	Unclear	<1 year		>1 year
17	5	187	22	51	31	5	55	34	222	32
		•			•				•	
		•							•	
		•			•				•	
		•							•	
							•		•	
		•							•	
							•	Unk	Unk	
			•						•	

Continued

Table 5.1—Cont'd

Authors	Year	Article title	Article designation			Populations tested		
			Article type	First category	Second category	Pets 182	Laboratory 48	Working dogs 25
Kaminski et al.	2008	Prospective object search in dogs: Mixed evidence for knowledge of <i>what</i> and <i>where</i> .	E	M	Sp.	•		
Miklósi	2008	Dog behaviour, evolution and cognition.	R	N-M	S-M	NA	NA	NA
Marshall-Pescini et al.	2008	Does training make you smarter? the effects of training on dogs' performance ( <i>Canis familiaris</i> ) in a problem-solving task.	E	OM	S-SL	•		
Bentosela et al.	2008	Effect of reinforcement, reinforcer omission and extinction on a communicative response in domestic dogs ( <i>Canis familiaris</i> ).	E	S-C		•		
Gaunet	2008	How do guide dogs of blind owners and pet dogs of sighted owners ( <i>Canis familiaris</i> ) ask their owners for food?	E	S-C		•		•

Sensory modalities focused on							Age groups			Age effects
Other	Unspecified	Visual	Olfactory	Auditory	Tactile	Taste	Unclear	<1 year	>1 year	
17	5	187	22	51	31	5	55	34	222	32
				•			•		•	
NA	NA	NA	NA	NA	NA	NA	NA	NA	NA	NA
		•			•				•	
							•		•	
							•		•	

*Continued*

Table 5.1—Cont'd

Authors	Year	Article title	Article designation			Populations tested		
			Article type	First category	Second category	Pets 182	Laboratory 48	Working dogs 25
Udell & Wynne	2008	A review of domestic dogs' ( <i>Canis familiaris</i> ) human-like behaviors: Or why behavior analysts should stop worrying and love their dogs.	R	S-M	OP	NA	NA	NA
Joly-Mascheroni, Senju, & Shepherd	2008	Dogs catch human yawns.	E	S-O		•		
Wynne et al.	2008	Ontogeny's impacts on human-dog communication.	C	S-R		NA	NA	NA
Prato-Previde et al.	2008	Is your choice my choice? the owners' effect on pet dogs' ( <i>Canis lupus familiaris</i> ) performance in a food choice task.	E	S-R	QU	•		
Riedel et al.	2008	The early ontogeny of human-dog communication.	E	S-R	DL	•		
Udell, Giglio, et al.	2008	Domestic dogs ( <i>Canis familiaris</i> ) use human gestures but not nonhuman tokens to find hidden food.	E	S-R	DL	•		
Udell, Dorey, et al.	2008	Wolves outperform dogs in following human social cues.	E	S-R		•		



Sensory modalities focused on								Age groups		Age effects
Other	Unspecified	Visual	Olfactory	Auditory	Tactile	Taste	Unclear	<1 year	>1 year	
17	5	187	22	51	31	5	55	34	222	32
NA	NA	NA	NA	NA	NA	NA	NA	NA	NA	NA
		•		•					•	
NA	NA	NA	NA	NA	NA	NA	NA	NA	NA	NA
		•							•	
		•						•	•	•
		•							•	
•		•							•	

Continued

Table 5.1—Cont'd

Authors	Year	Article title	Article designation			Populations tested		
			Article type	First category	Second category	Pets 182	Laboratory 48	Working dogs 25
Virányi et al.	2008	Comprehension of human pointing gestures in young human-reared wolves ( <i>Canis lupus</i> ) and dogs ( <i>Canis familiaris</i> ).	E	S-R			•	
Cracknell et al.	2008	Can stimulus enhancement explain the apparent success of the model-rival technique in the domestic dog ( <i>Canis familiaris</i> )?	E	S-SL	C/I	•		
Pongrácz et al.	2008	How does dominance rank status affect individual and social learning performance in the dog ( <i>Canis familiaris</i> )?	E	S-SL	Sp.	•		
Kaminski, Tempelmann, Call & Tomasello, et al.	2009	Domestic dogs comprehend human communication with iconic signs.	E	C/I		•		
Wobber & Hare	2009	Testing the social dog hypothesis: Are dogs also more skilled than chimpanzees in non-communicative social tasks?	E	DL	S-O	•		

Sensory modalities focused on							Age groups		Age effects	
Other	Unspecified	Visual	Olfactory	Auditory	Tactile	Taste	Unclear	<1 year		>1 year
17	5	187	22	51	31	5	55	34	222	32
		•						•		
		•		•					•	
		•					•		•	
		•		•					•	
		•							•	

Continued

Table 5.1—Cont'd

Authors	Year	Article title	Article designation			Populations tested		
			Article type	First category	Second category	Pets 182	Laboratory 48	Working dogs 25
Bentosela, Jakovcevic, Elgier, Mustaca, & Papini, et al.	2009	Incentive contrast in domestic dogs ( <i>Canis familiaris</i> ).	E	N-O	S-C	•		
Miller, Gipson, et al.	2009	Object permanence in dogs: Invisible displacement in a rotation task.	E	OP		•		
Miller et al.	2009b	What do dogs know about hidden objects?	E	OP	M	•		
Rooijackers et al.	2009	Comparing dogs and great apes in their ability to visually track object transpositions.	E	OP		•		
Marshall-Pescini et al.	2009	Agility and search and rescue training differently affects pet dogs' behaviour in socio-cognitive tasks.	E	S-C	OM	•		•
Topál, Miklósi, et al.	2009	The dog as a model for understanding human social behavior.	E	S-M		NA	NA	NA
Harr, Gilbert, & Phillips	2009	Do dogs ( <i>Canis familiaris</i> ) show contagious yawning?	E	S-O		•		

Sensory modalities focused on							Age groups			Age effects
Other	Unspecified	Visual	Olfactory	Auditory	Tactile	Taste	Unclear	<1 year	>1 year	
17	5	187	22	51	31	5	55	34	222	32
						•			•	
		•							•	
		•							•	
		•							•	
							•		•	
NA	NA	NA	NA	NA	NA	NA	NA	NA	NA	NA
		•		•					•	

*Continued*

Table 5.1—Cont'd

Authors	Year	Article title	Article designation			Populations tested		
			Article type	First category	Second category	Pets 182	Laboratory 48	Working dogs 25
Range, Horn, Virányi, & Huber	2009	The absence of reward induces inequity aversion in dogs.	E	S-O		•		
Horowitz	2009a	Attention to attention in domestic dog ( <i>Canis familiaris</i> ) dyadic play.	E	S-P		•		
Kaminski, Bräuer, et al.	2009	Domestic dogs are sensitive to a human's perspective.	E	S-P		•		
Elgier, Jakovcevic, Mustaca, et al.	2009	Learning and owner-stranger effects on interspecific communication in domestic dogs ( <i>Canis familiaris</i> ).	E	S-R		•		
Gácsi, Kara, et al.	2009	The effect of development and individual differences in pointing comprehension of dogs.	E	S-R		•		
Gácsi, McGreevy, et al.	2009	Effects of selection for cooperation and attention in dogs.	E	S-R		•		
Gácsi, Györi, et al.	2009	Explaining dog wolf differences in utilizing human pointing gestures: Selection for synergistic shifts in the development of some social skills.	E	S-R		•	•	

Sensory modalities focused on							Age groups			Age effects
Other	Unspecified	Visual	Olfactory	Auditory	Tactile	Taste	Unclear	<1 year	>1 year	
17	5	187	22	51	31	5	55	34	222	32
		•				•	•		•	
		•							•	
		•							•	
		•							•	
		•						•	•	•
		•							•	
		•						•	•	•

Continued

Table 5.1—*Cont'd*

Authors	Year	Article title	Article designation			Populations tested		
			Article type	First category	Second category	Pets 182	Laboratory 48	Working dogs 25
Ittyerah & Gaunet	2009	The response of guide dogs and pet dogs ( <i>Canis familiaris</i> ) to cues of human referential communication (pointing and gaze).	E	S-R		•		•
Lakatos, Soproni, Dóka, & Miklósi, et al.	2009	A comparative approach to dogs' ( <i>Canis familiaris</i> ) and human infants' comprehension of various forms of pointing gestures.	E	S-R		•		
Petter et al.	2009	Can dogs ( <i>Canis familiaris</i> ) detect human deception?	E	S-R		•		
Topál, Gergely, et al.	2009	Differential sensitivity to human communication in dogs, wolves, and human infants.	E	S-R	OP	•		
Wobber et al.	2009	Breed differences in domestic dogs' ( <i>Canis familiaris</i> ) comprehension of human communicative signals.	E	S-R		•		



Sensory modalities focused on								Age groups		Age effects
Other	Unspecified	Visual	Olfactory	Auditory	Tactile	Taste	Unclear	<1 year	>1 year	
17	5	187	22	51	31	5	55	34	222	32
		•							•	
		•							•	
		•		•					•	
		•		•					•	
		•							•	

*Continued*

Table 5.1—Cont'd

Authors	Year	Article title	Article designation			Populations tested		
			Article type	First category	Second category	Pets 182	Laboratory 48	Working dogs 25
Dorey et al.	2009	Breed differences in dogs sensitivity to human points: A meta-analysis.	R	S-R		NA	NA	NA
Reid	2009	Adapting to the human world: Dogs' responsiveness to our social cues.	R	S-R		NA	NA	NA
Elgier, Jakovcevic, Barrera, et al.	2009	Communication between domestic dogs ( <i>Canis familiaris</i> ) and humans: Dogs are good learners.	R/E	S-R	S-C	•		
Heberlein & Turner	2009	Dogs, <i>Canis familiaris</i> , find hidden food by observing and interacting with a conspecific.	E	S-SL		•		
Miller et al.	2009a	Imitation, emulation, by dogs using a bidirectional control procedure.	E	S-SL		•		
Range, Heucke, et al.	2009	The effect of ostensive cues on dogs' performance in a manipulative social learning task.	E	S-SL		•		
Range, Horn, Bugnyar, Gajdon, & Huber.	2009	Social attention in keas, dogs, and human children.	E	S-SL		•		

Sensory modalities focused on								Age groups		Age effects
Other	Unspecified	Visual	Olfactory	Auditory	Tactile	Taste	Unclear	<1 year	>1 year	
17	5	187	22	51	31	5	55	34	222	32
NA	NA	NA	NA	NA	NA	NA	NA	NA	NA	NA
NA	NA	NA	NA	NA	NA	NA	NA	NA	NA	NA
		•							•	
		•					•		•	
		•			•				•	
		•		•	•				•	
		•							•	

Continued

Table 5.1—Cont'd

Authors	Year	Article title	Article designation			Populations tested		
			Article type	First category	Second category	Pets 182	Laboratory 48	Working dogs 25
Tennie et al.	2009	Dogs, <i>Canis familiaris</i> , fail to copy intransitive actions in third-party contextual imitation tasks.	E	S-SL		•		
Kubinyi et al.	2009	Dog as a model for studying conspecific and heterospecific social learning.	R	S-SL		NA	NA	NA
Huber et al.	2009	The evolution of imitation: What do the capacities of nonhuman animals tell us about the mechanisms of imitation?	R/E	S-SL		•		
Fiset	2009	Evidence for averaging of distance from landmarks in the domestic dog.	E	Sp.		•		
Macpherson & Roberts	2010	Spatial memory in dogs ( <i>Canis familiaris</i> ) on a radial maze.	E	M	Sp.	•		
Miller, Pattison, DeWall, Rayburn-Reeves, & Zentall	2010	Self-control without a “self?” common self-control processes in humans and dogs.	E	N-O		•		
Faragó et al.	2010	Dogs' expectation about signalers' body size by virtue of their growls.	E	OL		•		

Sensory modalities focused on							Age groups			Age effects
Other	Unspecified	Visual	Olfactory	Auditory	Tactile	Taste	Unclear	<1 year	>1 year	
17	5	187	22	51	31	5	55	34	222	32
		•		•					•	
NA	NA	NA	NA	NA	NA	NA	NA	NA	NA	NA
		•			•				•	
		•							•	
							•		•	
							•		•	
		•		•					•	

Continued

Table 5.1—Cont'd

Authors	Year	Article title	Article designation			Populations tested		
			Article type	First category	Second category	Pets 182	Laboratory 48	Working dogs 25
Kundey, De Los Reyes, Taglang, Allen, et al.	2010	Domesticated dogs' ( <i>Canis familiaris</i> ) use of the solidity principle.	E	OL		•		
Pattison et al.	2010	The case of the disappearing bone: Dogs' understanding of the physical properties of objects.	E	OL		•		
Gaunet	2010	How do guide dogs and pet dogs ( <i>Canis familiaris</i> ) ask their owners for their toy and for playing?	E	S-C		•		•
Jakovcevic, Elgier, Mustaca, & Bentosela	2010	Breed differences in dogs' ( <i>Canis familiaris</i> ) gaze to the human face.	E	S-C		•		
Udell et al.	2010b	What did domestication do to dogs? A new account of dogs' sensitivity to human actions.	R	S-M		NA	NA	NA
Faragó, Pongrácz, Range, et al.	2010b	"The bone is mine": Affective and referential aspects of dog growls.	E	S-O		•		
Kundey, De Los Reyes, Taglang, et al.	2010	Domesticated dogs ( <i>Canis familiaris</i> ) react to what others can and cannot hear.	E	S-P		•		

Sensory modalities focused on							Age groups			Age effects
Other	Unspecified	Visual	Olfactory	Auditory	Tactile	Taste	Unclear	<1 year	>1 year	
17	5	187	22	51	31	5	55	34	222	32
		•							•	
		•							•	
							•		•	
							•		•	
NA	NA	NA	NA	NA	NA	NA	NA	NA	NA	NA
				•					•	
		•		•					•	

*Continued*

Table 5.1—Cont'd

Authors	Year	Article title	Article designation			Populations tested		
			Article type	First category	Second category	Pets 182	Laboratory 48	Working dogs 25
Fiset	2010	Comment on “differential sensitivity to human communication in dogs, wolves, and human infants.”	C	S-R	OP	NA	NA	NA
Topál, Miklósi, Sümegei, & Kis, et al.	2010	Response to comments on “differential sensitivity to human communication in dogs, wolves, and human infants.”	C	S-R	OP	NA	NA	NA
Udell & Wynne	2010	Ontogeny and phylogeny: Both are essential to human-sensitive behaviour in the genus <i>Canis</i> .	C	S-R		NA	NA	NA
van Rooijen	2010	Do dogs and bees possess a “theory of mind”?	C	S-R		NA	NA	NA
Hare et al.	2010	The domestication hypothesis for dogs’ skills with human communication: A response to Udell et al. (2008) and Wynne et al. (2008).	C/E	S-R				
Marshall-Pescini et al.	2010	Comment on “differential sensitivity to human communication in dogs, wolves, and human infants.”	C/E	S-R	OP	•		



Sensory modalities focused on								Age groups		Age effects
Other	Unspecified	Visual	Olfactory	Auditory	Tactile	Taste	Unclear	<1 year	>1 year	
17	5	187	22	51	31	5	55	34	222	32
NA	NA	NA	NA	NA	NA	NA	NA	NA	NA	NA
NA	NA	NA	NA	NA	NA	NA	NA	NA	NA	NA
NA	NA	NA	NA	NA	NA	NA	NA	NA	NA	NA
NA	NA	NA	NA	NA	NA	NA	NA	NA	NA	NA
•		•		•					•	
		•		•				Unk	Unk	

Continued

Table 5.1—*Cont'd*

Authors	Year	Article title	Article designation			Populations tested		
			Article type	First category	Second category	Pets 182	Laboratory 48	Working dogs 25
Dorey et al.	2010	When do domestic dogs, <i>Canis familiaris</i> , start to understand human pointing? the role of ontogeny in the development of interspecies communication.	E	S-R		•		
Győri, Gácsi, & Miklósi	2010	Friend or foe: Context dependent sensitivity to human behaviour in dogs.	E	S-R		•		
Helton & Helton	2010	Physical size matters in the domestic dog's ( <i>Canis lupus familiaris</i> ) ability to use human pointing cues.	E	S-R		•		
McMahon, Macpherson, & Roberts	2010	Dogs choose a human informant: Meta-cognition in canines.	E	S-R	DL	•		
Udell et al.	2010a	The performance of stray dogs ( <i>Canis familiaris</i> ) living in a shelter on human-guided object-choice tasks.	E	S-R				
Osthaus et al.	2010	Minding the gap: Spatial perseveration error in dogs.	E	Sp.		•		

Sensory modalities focused on								Age groups		Age effects
Other	Unspecified	Visual	Olfactory	Auditory	Tactile	Taste	Unclear	<1 year	>1 year	
17	5	187	22	51	31	5	55	34	222	32
		•						•		•
		•		•					•	
		•							•	
		•						Unk	Unk	
•		•							•	
		•					•		•	

Continued

Table 5.1—Cont'd

Authors	Year	Article title	Article designation			Populations tested		
			Article type	First category	Second category	Pets 182	Laboratory 48	Working dogs 25
Pilley & Reid	2011	Border Collie comprehends object names as verbal referents.	E	C/I		•		
Ashton & de Lillo	2011	Association, inhibition, and object permanence in dogs' ( <i>Canis familiaris</i> ) spatial search.	E	DL	Sp.	•		
Fischer-Tenhagen et al.	2011	Training dogs on a scent platform for oestrus detection in cows.	E	DL		•		
Nagasawa et al.	2011	Dogs can discriminate human smiling faces from blank expressions.	E	DL		•		
Demant et al.	2011	The effect of frequency and duration of training sessions on acquisition and long-term memory in dogs.	E	M			•	
Salvin, McGreevy, Sachdev, & Valenzuela	2011	The canine sand maze: An appetitive spatial memory paradigm sensitive to age-related change in dogs.	E	M	Sp.	•		
Burman et al.	2011	Using judgment bias to measure positive affective state in dogs.	E	N-O			•	

Sensory modalities focused on							Age groups		Age effects	
Other	Unspecified	Visual	Olfactory	Auditory	Tactile	Taste	Unclear	<1 year		>1 year
17	5	187	22	51	31	5	55	34	222	32
				•	•		•		•	
		•							•	
			•						•	
		•							•	
							•		•	
		•							•	•
		•							•	

Continued

Table 5.1—Cont'd

Authors	Year	Article title	Article designation			Populations tested		
			Article type	First category	Second category	Pets 182	Laboratory 48	Working dogs 25
Howell & Bennett	2011a	Can dogs ( <i>Canis familiaris</i> ) use a mirror to solve a problem?	E	N-O		•		
Frank	2011	Wolves, dogs, rearing and reinforcement: Complex interactions underlying species differences in training and problem-solving performance.	R/E	N-O	OP		•	
Bräuer & call	2011	The magic cup: Great apes and domestic dogs ( <i>Canis familiaris</i> ) individuate objects according to their properties.	E	OL		•		
Müller et al.	2011	Female but not male dogs respond to a size constancy violation.	E	OL		•		
Hiestand	2011	A comparison of problem-solving and spatial orientation in the wolf ( <i>Canis lupus</i> ) and dog ( <i>Canis familiaris</i> ).	E	OM			•	•
Range, Hentrup, et al.	2011	Dogs are able to solve a means-end task.	E	OM		•		
Bonanni et al.	2011	Free-ranging dogs assess the quantity of opponents in intergroup conflicts.	E	QU				

Sensory modalities focused on							Age groups			Age effects
Other	Unspecified	Visual	Olfactory	Auditory	Tactile	Taste	Unclear	<1 year	>1 year	
17	5	187	22	51	31	5	55	34	222	32
		•							•	
		•			•			•		
		•					•		•	
		•							•	
		•			•				•	
		•			•				•	
•							•		•	

Continued

Table 5.1—Cont'd

Authors	Year	Article title	Article designation			Populations tested		
			Article type	First category	Second category	Pets 182	Laboratory 48	Working dogs 25
Barrera et al.	2011	Communication between domestic dogs and humans: Effects of shelter housing upon the gaze to the human.	E	S-C		•		
Gaunet & Deputte	2011	Functionally referential and intentional communication in the domestic dog: Effects of spatial and social contexts.	E	S-C		•		
Kaminski, Neumann, et al.	2011	Dogs, <i>Canis familiaris</i> , communicate with humans to request but not to inform.	E	S-C		•		
Passalacqua et al.	2011	Human-directed gazing behaviour in puppies and adult dog, <i>Canis lupus familiaris</i> .	E	S-C		•		
Howell & Bennett	2011b	Puppy power! Using social cognition research tasks to improve socialization practices for domestic dogs ( <i>Canis familiaris</i> ).	R	S-M		NA	NA	NA
Kundey et al.	2011	Reputation-like inference in domestic dogs ( <i>Canis familiaris</i> ).	E	S-O		•		



Sensory modalities focused on								Age groups		Age effects
Other	Unspecified	Visual	Olfactory	Auditory	Tactile	Taste	Unclear	<1 year	>1 year	
17	5	187	22	51	31	5	55	34	222	32
•							•		•	
							•		•	
							•		•	
•							•	•	•	•
NA	NA	NA	NA	NA	NA	NA	NA	NA	NA	NA
		•							•	

Continued

Table 5.1—Cont'd

Authors	Year	Article title	Article designation			Populations tested		
			Article type	First category	Second category	Pets 182	Laboratory 48	Working dogs 25
O'Hara & Reeve	2011	A test of the yawning contagion and emotional connectedness hypothesis in dogs, <i>Canis familiaris</i> .	E	S-O		•		
Horowitz	2011	Theory of mind in dogs? examining method and concept.	C	S-P		NA	NA	NA
Miklósi & Topál	2011	On the hunt for the gene of perspective taking: Pitfalls in methodology.	C	S-P		NA	NA	NA
Roberts & Macpherson	2011	Theory of mind in dogs: Is the perspective-taking task a good test?	C	S-P		NA	NA	NA
Udell & Wynne	2011	Reevaluating canine perspective-taking behavior.	C	S-P		NA	NA	NA
Virányi & range	2011	Evaluating the logic of perspective-taking experiments.	C	S-P		NA	NA	NA
Udell et al.	2011	Can your dog read your mind? Understanding the causes of canine perspective taking.	E	S-P		•		

Sensory modalities focused on								Age groups		Age effects
Other	Unspecified	Visual	Olfactory	Auditory	Tactile	Taste	Unclear	<1 year	>1 year	
17	5	187	22	51	31	5	55	34	222	32
•		•		•					•	
NA	NA	NA	NA	NA	NA	NA	NA	NA	NA	NA
NA	NA	NA	NA	NA	NA	NA	NA	NA	NA	NA
NA	NA	NA	NA	NA	NA	NA	NA	NA	NA	NA
NA	NA	NA	NA	NA	NA	NA	NA	NA	NA	NA
NA	NA	NA	NA	NA	NA	NA	NA	NA	NA	NA
•		•							•	

Continued

Table 5.1—Cont'd

Authors	Year	Article title	Article designation			Populations tested		
			Article type	First category	Second category	Pets 182	Laboratory 48	Working dogs 25
Yamamoto, Ohtani, & Ohta	2011	The response of dogs to attentional focus of human beings: A comparison between guide dog candidates and other dogs.	E	S-P		•		•
Kupan et al.	2011	Why do dogs ( <i>Canis familiaris</i> ) select the empty container in an observational learning task?	E	S-R		•		
Lit et al.	2011	Handler beliefs affect scent detection dog outcomes.	E	S-R		•		
Marshall-Pescini, Prato-Previde, et al.	2011	Are dogs ( <i>Canis familiaris</i> ) misled more by their owners than by strangers in a food choice task?	E	S-R	QU	•		
Pettersson et al.	2011	Understanding of human communicative motives in domestic dogs.	E	S-R	S-P	•		
Scheider, Grassmann, Kaminski, & Tomasello	2011	Domestic dogs use contextual information and tone of voice when following a human pointing gesture.	E	S-R		•		

Sensory modalities focused on								Age groups		Age effects
Other	Unspecified	Visual	Olfactory	Auditory	Tactile	Taste	Unclear	<1 year	>1 year	
17	5	187	22	51	31	5	55	34	222	32
		•							•	
		•		•					•	
			•						•	
		•				•			•	
		•		•					•	
		•		•					•	

*Continued*

Table 5.1—Cont'd

Authors	Year	Article title	Article designation			Populations tested		
			Article type	First category	Second category	Pets 182	Laboratory 48	Working dogs 25
Kaminski, Nitzschner, et al.	2011	Do dogs distinguish rational from irrational acts?	E	S-SL	S-R	•		
Marshall-Pescini, Passalacqua, Ferrario, Valsecchi, & Prato-Previde	2011	Social eavesdropping in the domestic dog.	E	S-SL		•		
Mersmann et al.	2011	Simple mechanisms can explain social learning in domestic dogs ( <i>Canis familiaris</i> ).	E	S-SL		•	•	
Range, Huber, et al.	2011	Automatic imitation in dogs.	E	S-SL		•		
Griebel & Oller	2012	Vocabulary learning in a Yorkshire terrier: Slow mapping of spoken words.	E	C/I		•		
Ramos & Ades	2012	Two-item sentence comprehension by a dog ( <i>Canis familiaris</i> ).	E	C/I		•		
Somppi et al.	2012	Dogs do look at images: Eye tracking in canine cognition research.	E	C/I		•		
van der Zee et al.	2012	Word generalization by a dog ( <i>Canis familiaris</i> ): Is shape important?	E	C/I		•		

Sensory modalities focused on							Age groups		Age effects	
Other	Unspecified	Visual	Olfactory	Auditory	Tactile	Taste	Unclear	<1 year		>1 year
17	5	187	22	51	31	5	55	34	222	32
		•			•				•	
		•		•					•	
		•			•		•		•	
		•			•				•	
				•			•		•	
				•	•		•	Unk	Unk	
		•							•	
		•		•	•				•	

Continued

Table 5.1—*Cont'd*

Authors	Year	Article title	Article designation			Populations tested		
			Article type	First category	Second category	Pets	Laboratory	Working dogs
						182	48	25
Berns et al.	2012	Functional MRI in awake unrestrained dogs.	E	DL		•		
Howell et al.	2012	Auditory stimulus discrimination recorded in dogs, as indicated by mismatch negativity (MMN).	E	DL		•		
Jeziński, Sobczyńska, Walczak, Gorecka-Bruzda, & Ensminger	2012	Do trained dogs discriminate individual body odors of women better than those of men?	E	DL				•
Salvin, McGrath, McGreevy, & Valenzuela	2012	Development of a novel paradigm for the measurement of olfactory discrimination in dogs ( <i>Canis familiaris</i> ): A pilot study.	E	DL				•
Snigdha et al.	2012	Age and distraction are determinants of performance on a novel visual search task in aged beagle dogs.	E	DL			•	
Craig et al.	2012	Domestic dogs ( <i>Canis familiaris</i> ) and the radial arm maze: Spatial memory and serial position effects.	E	M	Sp.		•	



Sensory modalities focused on								Age groups		Age effects
Other	Unspecified	Visual	Olfactory	Auditory	Tactile	Taste	Unclear	<1 year	>1 year	
17	5	187	22	51	31	5	55	34	222	32
		•							•	
				•					•	
			•						•	
			•						•	•
		•							•	•
							•		•	

*Continued*

Table 5.1—*Cont'd*

Authors	Year	Article title	Article designation			Populations tested		
			Article type	First category	Second category	Pets 182	Laboratory 48	Working dogs 25
Fujita <i>et al.</i>	2012	Incidental memory in dogs ( <i>Canis familiaris</i> ): Adaptive behavioral solution at an unexpected memory test.	E	M	Sp.	•		
Miller & Bender	2012	The breakfast effect: Dogs ( <i>Canis familiaris</i> ) search more accurately when they are less hungry.	E	M	Sp.	•		
Nagasawa <i>et al.</i>	2012	A new behavioral test for detecting decline of age-related cognitive ability in dogs.	E	M		•		
Leonardi <i>et al.</i>	2012	Waiting for more: The performance of domestic dogs ( <i>Canis familiaris</i> ) on exchange tasks.	E	N-O	QU	•		
Müller <i>et al.</i>	2012	Brief owner absence does not induce negative judgment bias in pet dogs.	E	N-O		•		
Wright <i>et al.</i>	2012	Behavioural and physiological correlates of impulsivity in the domestic dog ( <i>Canis familiaris</i> ).	E	N-O		•		

Sensory modalities focused on								Age groups		Age effects
Other	Unspecified	Visual	Olfactory	Auditory	Tactile	Taste	Unclear	<1 year	>1 year	
17	5	187	22	51	31	5	55	34	222	32
		•							•	
		•							•	
		•							•	•
		•				•	•		•	
		•							•	
							•		•	

Continued

Table 5.1—*Cont'd*

Authors	Year	Article title	Article designation			Populations tested		
			Article type	First category	Second category	Pets 182	Laboratory 48	Working dogs 25
Range, Möslinger, et al.	2012	Domestication has not affected the understanding of means-end connections in dogs.	E	OM				•
Fiset & Plourde	2012	Object permanence in domestic dogs ( <i>Canis lupus familiaris</i> ) and gray wolves ( <i>Canis lupus</i> ).	E	OP		•		
Horn et al.	2012	Domestic dogs ( <i>Canis familiaris</i> ) flexibly adjust their human-directed behavior to the actions of their human partners in a problem situation.	E	S-C		•		
Jakovcevic et al.	2012	Do more sociable dogs gaze longer to the human face than less sociable ones?	E	S-C		•		
Miklósi & Szabó	2012	Modelling behavioural evolution and cognition in canines: Some problematic issues.	R	S-M		NA	NA	NA
Bräuer et al.	2012	Domestic dogs ( <i>Canis familiaris</i> ) coordinate their actions in a problem-solving task.	E	S-O		•		

Sensory modalities focused on							Age groups			Age effects
Other	Unspecified	Visual	Olfactory	Auditory	Tactile	Taste	Unclear	<1 year	>1 year	
17	5	187	22	51	31	5	55	34	222	32
		•			•				•	
		•							•	
							•		•	
							•		•	
NA	NA	NA	NA	NA	NA	NA	NA	NA	NA	NA
							•		•	

Continued

Table 5.1—*Cont'd*

Authors	Year	Article title	Article designation			Populations tested		
			Article type	First category	Second category	Pets 182	Laboratory 48	Working dogs 25
Custance & Mayer	2012	Empathic-like responding by domestic dogs ( <i>Canis familiaris</i> ) to distress in humans: An exploratory study.	E	S-O		•		
Nitzschner, Melis, Kaminski, & Tomasello	2012	Dogs ( <i>Canis familiaris</i> ) evaluate humans on the basis of direct experiences only.	E	S-O		•		
Range, Leitner, & Virányi	2012	The influence of the relationship and motivation on inequity aversion in dogs.	E	S-O		•		
Silva, Bessa, & de Sousa	2012	Auditory contagious yawning in domestic dogs ( <i>Canis familiaris</i> ): First evidence for social modulation.	E	S-O		•		
Bräuer et al.	2012	Domestic dogs conceal auditory but not visual information from others.	E	S-P		•		
Kaminski, Pitsch, et al.	2012	Dogs steal in the dark.	E	S-P		•		
Buttelmann & Tomasello	2012	Can domestic dogs ( <i>Canis familiaris</i> ) use referential emotional expressions to locate hidden food?	E	S-R		•		•

Sensory modalities focused on								Age groups		Age effects
Other	Unspecified	Visual	Olfactory	Auditory	Tactile	Taste	Unclear	<1 year	>1 year	
17	5	187	22	51	31	5	55	34	222	32
	•						•		•	
							•		•	
		•				•	•		•	
				•					•	
		•		•					•	
		•							•	
		•							•	

Continued

Table 5.1—Cont'd

Authors	Year	Article title	Article designation			Populations tested		
			Article type	First category	Second category	Pets 182	Laboratory 48	Working dogs 25
Elgier, Jakovcevic, Mustaca, & Bentosela	2012	Pointing following in dogs: Are simple or complex cognitive mechanisms involved?	E	S-R		•		
Grassmann et al.	2012	How two word-trained dogs integrate pointing and naming.	E	S-R	C/I	•		
Kaminski, Schulz, et al.	2012	How dogs know when communication is intended for them.	E	S-R	S-P	•		
Kis et al.	2012	Does the A-not-B error in adult pet dogs indicate sensitivity to human communication?	E	S-R	OP	•		
Kundey et al.	2012	Domestic dogs' ( <i>Canis familiaris</i> ) choices in reference to agreement among human informants on location of food.	E	S-R		•		
Lakatos et al.	2012	Comprehension and utilization of pointing gestures and gazing in dog-human communication in relatively complex situations.	E	S-R	S-C	•		



Sensory modalities focused on							Age groups			Age effects
Other	Unspecified	Visual	Olfactory	Auditory	Tactile	Taste	Unclear	<1 year	>1 year	
17	5	187	22	51	31	5	55	34	222	32
		•							•	
		•		•					•	
		•		•				•	•	•
		•		•					•	
		•							•	
		•					•		•	

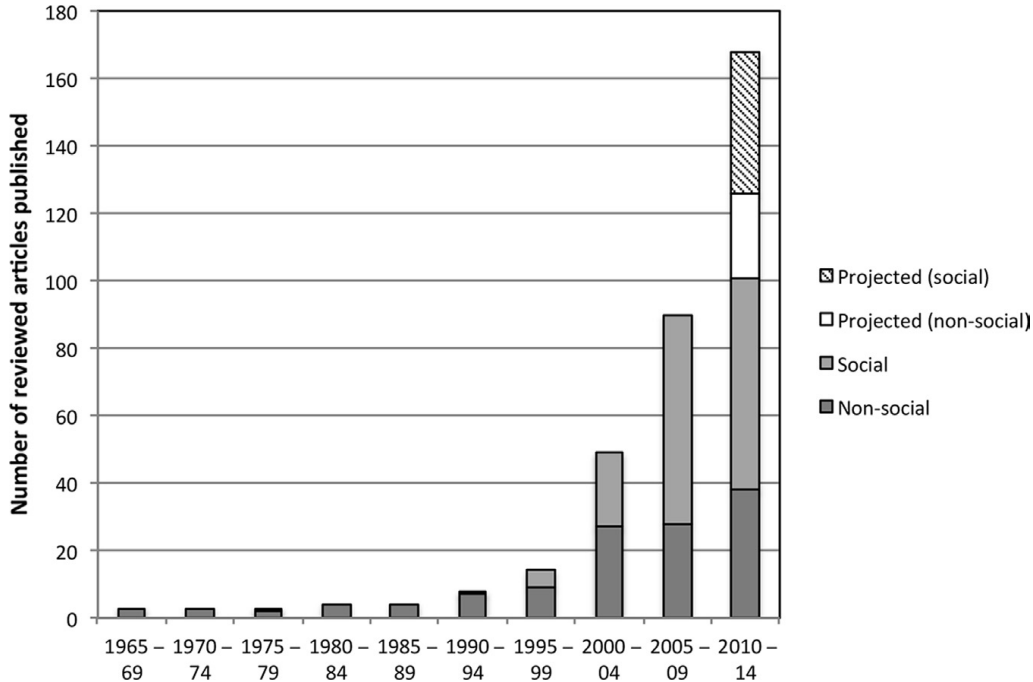
Continued

Table 5.1—Cont'd

Authors	Year	Article title	Article designation			Populations tested		
			Article type	First category	Second category	Pets 182	Laboratory 48	Working dogs 25
Marshall-Pescini et al.	2012	Do dogs ( <i>Canis lupus familiaris</i> ) make counterproductive choices because they are sensitive to human ostensive cues?	E	S-R	QU	•		
Scheider, Kaminski, Call, & Tomasello	2012	Do domestic dogs interpret pointing as a command?	E	S-R		•		
Téglás et al.	2012	Dogs' gaze following is tuned to human communicative signals.	E	S-R		•		
Huber et al.	2012	Dogs imitate selectively, not necessarily rationally: Reply to Kaminski et al. (2011).	C	S-SL		NA	NA	NA
Merola, Prato-Previde, & Marshall-Pescini	2012a	Dog's social referencing toward owners and strangers.	E	S-SL		•		
Merola, Prato-Previde, & Marshall-Pescini.	2012b	Social referencing in dog-owner dyads?	E	S-SL		•		
Pongrácz et al.	2012	When rank counts—dominant dogs learn better from a human demonstrator in a two-action test.	E	S-SL		•		

Sensory modalities focused on								Age groups		Age effects
Other	Unspecified	Visual	Olfactory	Auditory	Tactile	Taste	Unclear	<1 year	>1 year	
17	5	187	22	51	31	5	55	34	222	32
		•		•					•	
		•		•					•	
		•		•					•	
NA	NA	NA	NA	NA	NA	NA	NA	NA	NA	NA
		•		•					•	
		•		•					•	
		•			•				•	

inform behavioral decisions related to social interactions. Of course, these broad classifications are not mutually exclusive, but the split is a useful convention widely adopted in the field (e.g. Miklósi, 2008). Overall, 54.7% of the reviewed studies (156 of the 285 in our pool) were classified as being primarily focused on topics in the realm of social cognition, while the remaining studies had their primary focus on a facet of nonsocial cognition. To illustrate the broad trends for research in social versus nonsocial cognition, we started by plotting the number of canine cognition articles published since 1965 (the date at which the 285 articles in our review began to appear consistently; only six were published before this date). As shown in Fig. 5.1, there has been a surge of published research on dog cognition over the last 15 years, largely driven by the recent interest in research related to canine social cognition. Only eight of the reviewed articles were published between 1990 and 1994, and we categorized only one (12.5%) of them as being related to social cognition. From 1995 to 1999, a total of 14 articles were published with five (35.7%) being related to social cognition. Since then, the number of dog cognition papers published, particularly those related to social cognition, has grown significantly with 49 articles



**Figure 5.1** Articles on dog cognition published every five years since 1965. Publications are divided into nonsocial and social publications based on classifications given in Table 5.1. Projections through 2014 are based on the average number of articles published each year between January 2010 and December 2012.

(44.9% social) published between 2000 and 2004, 90 articles (68.9% social) between 2005 and 2009, and a projection of around 170 articles (~62% social) to be published between 2010 and the end of 2014.

Across both nonsocial and social studies, we were also interested in describing our sample of articles in terms of the sensory modality studied, the source population of dogs, and the age of subject dogs. To classify articles according to the sensory modality under study (e.g. vision versus olfaction, etc.), we focused on the experimental manipulations executed and did our best to identify which sensory modalities were being influenced. Such categories were not mutually exclusive because many articles included multiple substudies with multiple sensory modality manipulations. Additionally, there were a number of articles where the sensory modality under investigation was partially or completely unclear (these articles were categorized as “unclear”). Of the 285 articles reviewed, 253 included original empirical research. Of these 253 empirical articles, 187 (73.9%) used visual stimulus protocols. Far fewer of the reviewed studies directly focused on how other sensory modalities impacted cognition. For example, 51 (20.2%) were categorized as having manipulations clearly related to auditory cues, and 22 (8.7%) focused on olfactory manipulations. Studies that involved either direct tactile cues or object manipulation were categorized as “tactile”; 31 (12.3%) of the selected articles met this criteria. We categorized five studies (2.0%) as “taste”, since these studies all manipulated the use of preferred versus nonpreferred food. There were 55 (21.7%) articles that were classified as “unclear”.

In stark contrast to the canine personality literature (Jones & Gosling, 2005), relatively few of the dog cognitive studies reviewed have used working-dogs. Instead, 182 (71.9%) of these articles used subjects that were pets volunteered by their owners, and 48 (19.0%) of the articles used subjects that were bred and/or raised specifically for laboratory research. Working-dogs were used in 25 (9.9%) of studies and 22 (8.7%) studies either sampled dogs from other dog populations (e.g. shelters, feral dogs, professional dog breeders) or the source of the dogs was unspecified.

To further categorize the articles based on the populations of dogs sampled, we also labeled each article based on the average age of the different groups of dogs tested. We then categorized studies based on whether they used dogs where the average age was either less than one year (a puppy) or greater than one year (a sexually mature adult). Where studies used multiple age groups, we classified articles into both. Additionally, we identified cross-sectional and longitudinal studies that examined potential age effects versus those that offered a single “snapshot” of cognition. In total, 222 (87.7%)

of the reviewed articles used samples where the mean age of the dogs was above one year, while 34 (13.4%) included samples of dogs that could be considered “puppies.” In terms of cognitive developmental research, only 32 (12.6%) studies used cross-sectional or longitudinal research techniques to compare the performance of different age groups.

One other qualitative trend emerged in our review. The majority of the articles analyzed data at the level of the population; far fewer studies focused on analyses between groups of dogs in a population or individual dogs within a population. While this is to be expected with the research of any species, the dog presents some interesting opportunities for intraspecies’ comparisons with regard to different breeds, rearing environments, and training levels. Thus far, research that has examined how distinct groups of dogs differ from one another on cognitive performance is not extensive though it is growing. There have only been a few studies that directly examined breed or breed-group differences in cognition with most of them published recently (e.g. Gácsi, McGreevy, Kara, & Miklósi, 2009; Passalacqua *et al.*, 2011; Wobber, Hare, Koler-Matznick, Wrangham, & Tomasello, 2009; but see: Gagnon & Doré, 1992; Scott & Fuller, 1965). We also observed that recent studies have begun to compare the performance of dogs that have experienced different amounts or types of training earlier in life (e.g. Gaunet, 2008, 2010; Marshall-Pescini, Passalacqua, Barnard, Valsecchi, & Prato-Previde, 2009; Marshall-Pescini, Valsecchi, Petak, Accorsi, & Prato-Previde, 2008; McKinley & Sambrook, 2000). Additionally, the potential for sex differences in canine cognition has just begun to be explored (Müller, Mayer, Dörrenberg, Huber, & Range, 2011).

In addition, while individual differences in performance are at times acknowledged, few researchers analyze data at the level of the individual. Typically, individual performances have been treated as statistical noise. Though there are a number of examples of researchers reporting individual performances and even tracking the performance of individuals through trial-by-trial analysis (e.g. Aust, Range, Steurer, & Huber, 2008; Miller, Rayburn-Reeves, & Zentall, 2009b; Udell, Giglio, & Wynne, 2008), analysis of these differences have mostly been limited to posthoc discussion. It is highly unlikely that all dogs perceive and approach environmental challenges the same way. However, research pertaining to the consistency of individual differences and how performances correlate across different domains of cognition are currently rare (though see Gácsi, Kara, Belényi, Topál, & Miklósi, 2009; Head, Callahan, Muggenburg, Cotman, & Milgram, 1998), and the potential for research focused on individual differences is great (see Section 5).

Of course, like any review our summary statistics and qualitative inferences regarding previous research is biased by our selection procedure (e.g. we excluded olfactory-based detection job competence demonstrations; Section 4.1.1). Thus, within the material reviewed, the majority of research has utilized mostly visual-oriented cognitive tasks using adult pet dogs; levels of inference across dog cognition studies vary, but tend to focus on general dog populations, rather than specific groups or individuals.



---

## 4. WHAT DO WE KNOW?

The studies reviewed below are critical to developing an understanding of a dog's *Umwelt*, or how dogs perceive and organize the world around them (Horowitz, 2009b; von Uexkull, 1934/1957). Understanding another animal's point of view is critical to understanding their behaviors and their decision-making ability. We start here by describing the research findings related to nonsocial cognition. An understanding of nonsocial processes will help provide a foundation of knowledge for how dogs use stimuli outside of a social context, giving us a baseline of behavior with which to evaluate the subsequent effects of additional social stimuli.

### 4.1. Nonsocial Cognition

Nonsocial cognition studies focus on how dogs perceive physical stimuli that make up their environment, how they develop mental representations of these stimuli, and/or how dogs utilize abiotic elements to solve a variety of tasks. Based on the content of the articles reviewed and the categorizations used in the broader animal cognition literature (e.g. Hauser, 2000; Shettleworth, 2010; Wasserman & Zentall, 2006; Wynne, 2001), we divided the domain of nonsocial cognition into the following eight subcategories: discrimination learning, object permanence, object learning, categorization/inferential reasoning, object manipulation problem-solving, quantitative understanding, spatial cognition, and memory (Table 5.1).

#### 4.1.1. Discrimination Learning

Discrimination learning involves the ability to learn to discriminate between similar stimuli through differential reward contingencies (Kehoe, 2008). Stimulus discrimination is vital to solving problems effectively and efficiently obtaining rewards beyond chance levels. The ability to learn to respond to arbitrary stimuli is particularly pertinent to dog training because the stimuli that many dogs are often trained on have no initial

intrinsic biological relevance to the dog (e.g. verbal cues, explosives odors). Physical stimuli can differ in a large number of respects, so it is important to determine the elements that are most salient to dogs when learning to discriminate.

Much of the research investigating learning mechanisms related to stimulus discrimination in dogs has relied on visual discriminatory stimuli. One common visual paradigm is the two-choice discrimination task, which makes use of objects that differ on figurative characteristics (e.g. shape, color, size, etc.). For example, [Milgram, Head, Weiner, and Thomas \(1994\)](#) found that dogs were capable of discriminating between two very discrete inanimate objects (a blue lego and an orange coffee jar lid) in order to effectively select the location of a hidden food reward. Overall, younger dogs (age 1.5–2.0 years) were able to learn to discriminate between the lego and the lid in fewer trials than older dogs (however, within the age groups individual performance varied widely such that it took dogs anywhere from 20 to 180 trials to reach the learning criterion established by the authors). Senior dogs (those older than 11 years) performed significantly worse than younger dogs on two-choice discrimination tasks; as dogs age they experience both increased cognitive processing durations and a reduced ability to ignore distraction stimuli ([Snigdha et al., 2012](#)). Studies have used more subtle figurative cue differences as well. For example, dogs have been shown to discriminate between black/white stimuli (e.g. [Araujo, Chan, Winka, Seymour, & Milgram, 2004](#); [Burman et al., 2011](#); [Frank, 2011](#)) and between two objects that differ only in size ([Milgram, 2003](#); [Tapp, Siwak, Estrada, Head, et al., 2003](#)). A direct comparison between learning based on black/white and size cues indicated marginally slower learning in the size-discrimination task ([Milgram et al., 2000](#)).

Other studies have examined the dog's use of spatially-based visual discrimination cues, such as when a reward location is signaled by the placement of an external landmark ([Milgram et al., 1999, 2002](#)) or is in a particular relationship to the dog's body position (e.g. select the location furthest to the left: [Ashton & De Lillo, 2011](#); [Chan et al., 2002](#); [Christie et al., 2005](#)). Dogs are clearly capable of using both sources of information, but there is some evidence that learning efficiency is improved using cues based on body position versus external landmarks ([Milgram et al., 1999](#)). Age has been shown to influence learning about associations between landmarks and rewards; older dogs tend to have more difficulty learning to associate rewards with landmarks relative to younger dogs, while no age effects were found in the acquisition of learning relative to body position



(Christie et al., 2005). Discrimination learning has also been shown to be more effective through the use of spatial cues compared to those based on figurative information (Dumas, 1998; Head et al., 1995).

The everyday occurrence of dogs being trained to respond to verbal commands/acoustic signals and the widespread use of dogs for odor detection clearly demonstrates that dogs can also learn to differentially respond to non-visual discriminatory stimuli. To explore learning of auditory discriminations, researchers have utilized “go-no-go” paradigms (e.g. Brown & Sołtysik, 1971; Kuśmierk & Kowalska, 1998; Shepherd, 1919) in which the dogs must learn to make a behavioral response only when presented with one stimulus (S+) and not another (S-). Shepherd (1919) found evidence of dogs learning to discriminate based on musical tones using such a procedure.

Others have used electronically controlled tonal frequencies, and demonstrated that dogs can discriminate between matched or mismatched pairs of tones (Brown & Sołtysik, 1971; Kuśmierk & Kowalska, 1998; Pierrzykowska & Sołtysik, 1975b). Auditory discrimination learning has also been measured through the use of a match-to-sample paradigm whereby dogs learn to press a pedal in the direction of a sound sample that matches a trial-unique sound stimulus presented at the beginning of each trial (Kowalska, 1997; Kuśmierk & Kowalska, 1998, 2002).

The audible cues presented in the above studies were completely arbitrary from the standpoint of the animal subjects. However, it should not be assumed that all sounds are equally effective in eliciting any behavioral response. Interestingly, the acoustic structure of the human vocal signal has been shown to affect a dog's behavioral response during training. For example, when training a puppy to come, human vocal signals consisting of repeated short vocal tones (versus a single long tone) more effectively elicit approach behavior and general motor activity (McConnell, 1990). Thus, the features of the acoustic stimuli and the required behavior can impact the rate of learning.

Various discrimination-learning paradigms, including the ones already discussed here, have been developed to incorporate olfactory stimuli (e.g. Schoon, 1997; for a review see Lit, 2009). Yet, much of the literature utilizing such paradigms is aimed at providing empirical support for the efficacy of using dogs for a particular job and thus exclusively focus on post-training results (however, see Fischer-Tenhagen, Wetterholm, Tenhagne, & Heuwieser, 2011; Jeziński et al., 2008 as examples where learning during training was analyzed). To date, far less research has focused on the acquisition of olfactory-based discriminations or analyzed the factors that affect such learning. Williams and Johnston (2002) conducted one example

of such a study by evaluating the effects of training a dog on multiple scents on that dog's ability to correctly identify numerous single targets. Interestingly, increasing the number of trained odors (up to 10) did not decrease the detection of previously learned odors, and in fact decreased the amount of time spent on refresher training for previously learned odors and the time needed to be trained on new ones.

However, our literature search identified no olfaction-based research similar to the visual discrimination paradigms discussed above (where the rate of discrimination learning based solely on olfactory cues can be measured over discrete standardized trials). Yet, paradigms have been developed in other species to analyze the acquisition of novel olfactory discriminations (e.g. mice: Mihalick, Langlois, Krienke, & Dube, 2000; primates: Hübener & Laska, 2001), and similar research in dogs is currently underway. Hall, Smith, and Wynne (*in press*) have recently conducted research utilizing a two-choice olfactory-based paradigm that measures the rate at which experimentally naïve dogs learn a novel odor discrimination task. Importantly, by measuring the rate of learning by counting the number of discrete trials needed to reach a predetermined criterion, this paradigm provides a clear quantitative outcome variable that allows researchers to compare the performance of individuals and different experimental groups, thus demonstrating the ability of this paradigm to assess different factors.

Hall *et al.* (*in press*) also directly compared discrimination acquisition between two sensory modalities (i.e. vision and olfaction) over discrete learning trials, and found that dogs learned the discrimination task faster based on olfactory cues versus visual ones. Previous research has compared how dogs utilize different sensory cues during detection and tracking work (e.g. Gazit & Terkel, 2003; Hepper & Wells, 2005), but direct comparisons between learning rates have been rare (though see Brown & Sołtysik, 1971; Piertrzykowska & Sołtysik, 1975a, 1975b). Continuing multisensory discrimination-learning research should provide critical insights into a dog's *Umwelt*, allowing greater understanding of the saliency of different sensory modality cues, as well as allowing for the analysis of individual differences and context-specific discrimination learning.

Finally, as a measure of behavioral flexibility, a common extension of the discrimination paradigm is to evaluate the impact of contingency reversal on learning (e.g. Bacon & Stanley, 1970; Fuller, 1966). In this paradigm, once the subject has met the criteria of learning the initial discrimination, the experimenters switch the contingencies so that the

previously rewarded cue now lacks an associated reward, and the reward instead is associated with the previously unrewarded cue. Studies have consistently found that dogs have a difficult time inhibiting the initially learned response, and thus reversal learning typically is found to be much slower than the initial discrimination acquisition (Ashton & De Lillo, 2011; Frank, 2011; Milgram, 2003; Tapp, Siwak, Estrada, Head, et al., 2003). Ashton and De Lillo (2011) even demonstrated that dogs ignored direct visual cues—signaling changes in reward baiting (e.g. the experimenters conspicuously hid the reward in the new location), indicating strong carryover effects of previous associative learning on the current behavioral responses. Again, age effects have been found with older dogs showing slower reversal learning relative to younger dogs (Milgram et al., 1994; Tapp, Siwak, Estrada, Head, et al., 2003).

*Discrimination-learning synthesis and future directions:* Dogs can clearly learn to discriminate between various arbitrary stimuli based on differential reward contingencies. However, research indicates that some stimuli are more salient than others. For example, dogs generally learn to discriminate based on spatial cues that are related to their own body position faster than they learn to discriminate based on the location of external landmarks. Dogs also appear to have an easier time learning to discriminate based on black/white shading over differences in size. The majority of the research in this area has used visual discriminations, but clearly dogs can learn discriminations based on both auditory and olfactory stimuli as well. Future research could focus on how nonvisual senses relate to discrimination learning, measuring which sensory cues are most salient to dogs in general, and examining the influence of interactions among different sensory modalities on discrimination learning. Further research should also explore how differences in context might affect stimulus saliency as well as factors that may lead to individual differences in the ability of dogs to learn based on different cues.

Also, recent research describes the development of minimally invasive techniques aimed at measuring the neurophysiology of the dog's ability to discriminate stimuli (Berns, Brooks, & Spivak, 2012; Howell, Conduit, Toukhsati, & Bennett, 2012). It will be interesting to see how this research develops further and whether it can be used in other domains of dog cognition research. Continued neurobiological research may provide novel insights for the biological basis of canine learning and decision making, as well as allowing comparative analyses between observed cognitive outcomes in dogs and other animals, including humans.

#### 4.1.2. *Object Permanence*

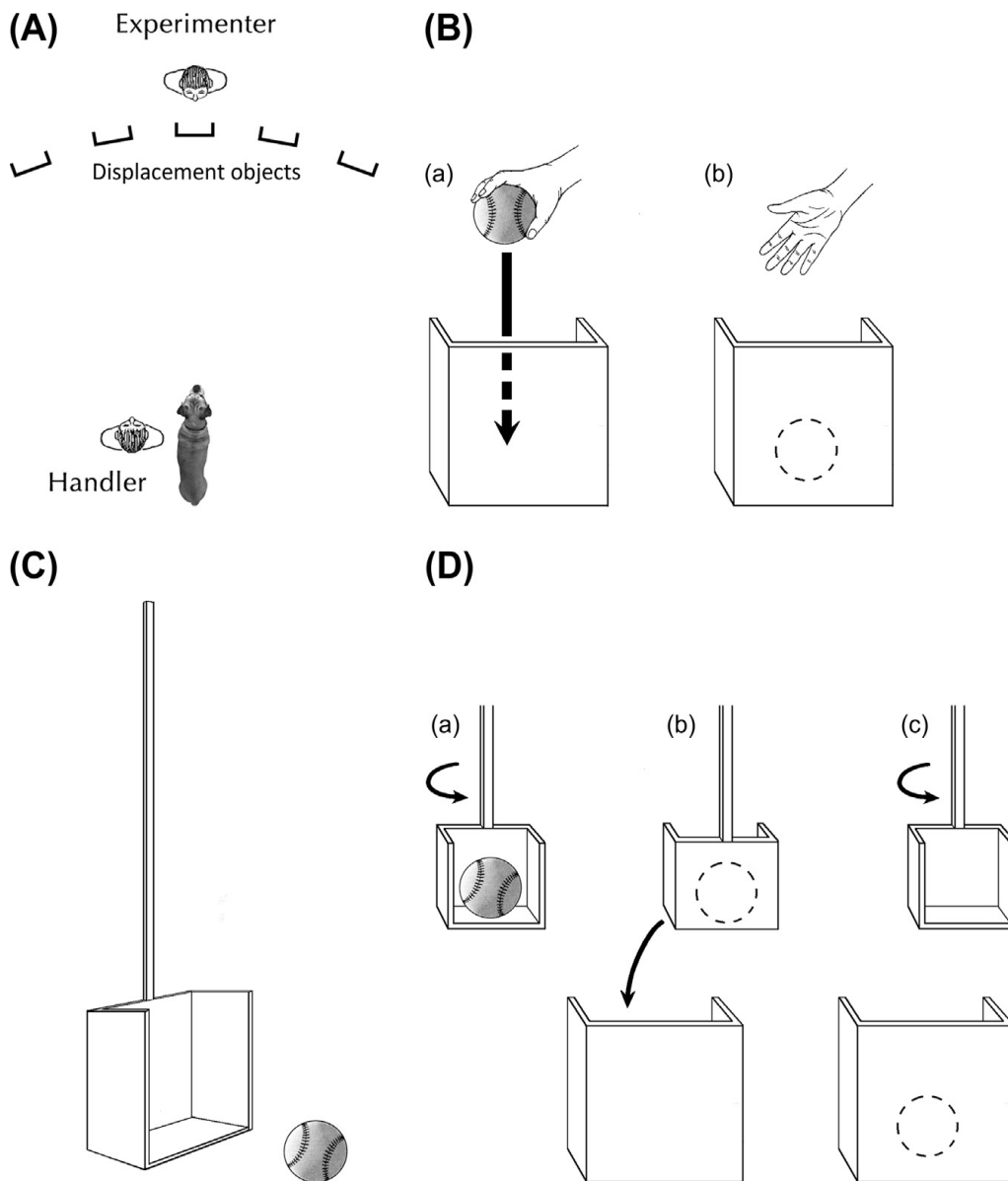
The concept of object permanence pertains to the ability of an animal to understand that objects continue to exist outside of their field of perception. Developmental psychologist Jean Piaget described the development of object permanence in human infants as having six stages (Piaget, 1936), and this stepwise approach has been found to have useful applications in the research of parallel cognitive abilities in nonhuman animals (Doré & Dumas, 1987). Piaget's Stage 4 represents the most elementary understanding of object permanence. At Stage 4, subjects are capable of spontaneously retrieving a target object that has been fully hidden from their view when they have directly witnessed the object being hidden. At Stage 5a, subjects are capable of performing well on multiple trials of visible displacement in which the hiding location is different between trials. This task is called "sequential visible displacement" and human infants who are still at Stage 4 will fail at this task due to persistent searching of the location where the target object was hidden on previous trials despite seeing the object being hidden in a new location ("A-not-B" errors). Subjects are considered to have a Stage 5b understanding of object permanence if they are successful at "successive visible displacement." In contrast to the more basic visible displacement tasks where the target object is only displaced behind one screen per trial, in a single "successive visible displacement" trial the experimenter will move the object behind multiple screens before leaving it behind the last visited location.

The ability to reach Stage 5 object permanence understanding in dogs has consistently been found in the literature. Triana and Pasnak (1981) found that dogs were able to successfully solve the successive visible displacement task, even when controlling for potential olfactory cues, and their findings have been replicated (Fiset & Plourde, 2012; Gagnon & Doré, 1992, 1994; Watson *et al.*, 2001). However, the majority of subsequent studies have not directly examined successive visible placement, but instead have used a procedure in which the target object only visits and is hidden at one randomized location per trial. Dogs have consistently performed well on these trial-unique object permanence tasks, indicating their understanding of visible displacement relies heavily on immediate perceptive cues rather than on actions associated with previously successful trials (Fiset, Beaulieu, & Landry, 2003; Fiset & LeBlanc, 2007; Gagnon & Doré, 1993; Miller, Gipson, Vaughan, Rayburn-Reeves, & Zentall, 2009; Miller *et al.*, 2009b). Cross-sectional research suggests that Stage 5 object permanence is fully developed at 8 weeks old, and that dogs do not show evidence of

making A-not-B errors during this development (Gagnon & Doré, 1994). Yet under some conditions, such as when large numbers of previous trials are used to establish the initial reward location (Ashton & De Lillo, 2011) or through the use of ostensive cues from the human hiding the target object (Kis et al., 2012; Topál, Gergely, Erdőhegyi, Csibra, & Miklósi, 2009), A-not-B errors can be induced in dogs, but the conclusion that domestic dogs reach at least Stage 5 of object permanence development is no longer debated.

What is more controversial is whether dogs reach Stage 6 of Piaget's object permanence development model. To establish Stage-6 development subjects must successfully solve invisible displacement tasks in which the hiding of a target object is not directly witnessed, but instead requires inferential reasoning based on indirect evidence (e.g. seeing the displacement tool is empty after passing behind a screen; Fig. 5.2). Earlier studies claimed that dogs could successfully solve successive invisible displacement tasks (Pasnak, Kurkjian, & Triana, 1988; Triana & Pasnak, 1981), though they also found that dogs performed significantly worse on invisible displacement when compared to their performance on visible displacement tasks (Gagnon & Doré, 1992, 1993). Gagnon and Doré (1992) specifically controlled for olfactory cues and looked for evidence of associative learning strategies, such as "always search the screen that comes into contact with the displacement tool" or "always search the screen that the displacement tool is shown to be empty after visiting it." Using associative cues would result in successful searches without the dogs having to mentally represent the unperceived displacement of the target object behind the screen, but presumably it would take a few trials for the dogs to learn this strategy. Gagnon and Doré (1992) found no evidence of olfactory cues facilitating search performance, and also found no increase in the overall performance of the dogs over test trials sessions, indicating that associative learning strategies did not appear to fully explain how dogs were able to successfully solve invisible displacement tasks. Puppies appear to have little success on invisible displacement trials, but performance does improve across the first year of life, leading Gagnon and Doré (1994) to suggest that Stage 6 object permanence in dogs begins to form at around one year of age.

However, positive results with invisible displacement tasks have not always been replicated (Doré, Fiset, Goulet, Dumas, & Gagnon, 1996). More recent findings suggest that dogs are unable to infer unperceived movement of target objects and instead resort to simpler associative learning strategies to guide search behavior. By analyzing search latencies and error patterns, researchers have concluded that associative learning strategies based



**Figure 5.2** (A) Generalized experimental set up for tests of object permanence used in dog studies. (B) Illustration of a visible displacement, where the dog first sees the target object directly placed behind the displacement object, and then sees the human remove their hand without the target object. (C) An example of a displacement tool, which is used to transport the target object for an invisible displacement task. (D) Illustration of an invisible displacement, where the dog sees the target object placed into the displacement tool before the device is turned around to hide the object. While the target object is still hidden the displacement tool deposits the target object behind the displacement object, and then the displacement tool is removed and shown to be empty.

on inadvertent cues have likely resulted in the better than chance-level performances in invisible displacement tasks previously witnessed in dogs (Collier-Baker, Davis, & Suddendorf, 2004; Fiset & LeBlanc, 2007; Rooijackers, Kaminski, & Call, 2009; Watson et al., 2001). Collier-Baker et al. (2004) gathered some of the most compelling evidence indicating that dogs have not demonstrated Stage-6 object permanence. Gagnon and Doré (1992) stated that a general effort was made to avoid giving inadvertent cues but there were no explicit control conditions to measure the influence of such cues. Given that dogs are skilled at detecting subtle changes in human body language (See Section 4.3.1), and that invisible displacement tasks require some face-to-face interactions between the experimenter and subject, it is important that the presence of inadvertent cues be actively controlled for (Box 5.1). Using similar procedures as Gagnon and Doré (1992), but with more explicit controls, Collier-Baker et al. (2004) blocked the dog's view of the experimenter during the trials using a sheet. Additionally, while Gagnon

### Box 5.1 Controlling for confounding variables

In any empirical field, it is important that researchers clearly demonstrate that the variables being manipulated are in fact responsible for the measured experimental effects. Here, we outline three confounding variables commonly discussed in the canine cognition literature and describe some of the strategies used by researchers to address them.

*Human social cues:* The story of Clever Hans (Pfungst, 1907) serves as a constant reminder that researchers need to be cautious about the conclusions that are drawn from animal-cognition research, particularly in studies that require a human experimenter to be present. Clever Hans was a horse that was thought to be able to do arithmetic and provide the answers to questions by tapping his foot. However, it was eventually shown that Clever Hans was not using math, but was actually responding to inadvertent cues (e.g. subtle changes in facial expressions) from his trainer and observers. Dogs are adept at noticing subtle changes in human behavior (Agnetta et al., 2000; Nagasawa, Murai, Mogi, & Kikusui, 2011) so the potential confounding role of inadvertent human cues has received deserved attention in canine cognition research.

To eliminate the potential of dogs responding to the experimenter's subtle inadvertent behaviors, in cases where the experiment requires the dog to view some manipulation within the environment, barriers and systems using strings have been used to prevent the dogs from witnessing the human manipulators' actions (e.g. Fiset & LeBlanc, 2007; Nagasawa, Yetsuzuka, Mogi, & Kikusui, 2012; Pattison et al., 2010). Even when researchers are interested in measuring how dogs respond to human social cues, experimenters often use control trials in

*Continued*

**Box 5.1 Controlling for confounding variables—cont'd**

which all human cues (except the one of experimental interest) are matched; these procedures ensure that it is the specific social cues the experimenters are manipulating that is influencing the dog's behavior (e.g. Hare & Tomasello, 1999; Miklósi *et al.*, 1998; Udell, Giglio, *et al.*, 2008). Often canine cognition studies require a human (either the dog's owner or an experimenter) to restrain the dog while a manipulation is executed and before a dog is allowed to make a behavioral response. To help control for inadvertent tactile cues from being conveyed to the dog subject, some experimenters have made sure the handler was naïve to manipulation outcomes by either blindfolding them, having them look away, or having them close their eyes (Burman *et al.*, 2011; Collier-Baker *et al.*, 2004; Miller *et al.*, 2009, 2009b). In some cases, experimenters also kept the handlers/owners naïve to the purpose of the experiment (Watson *et al.*, 2001), or conducted trials without the owner present (e.g. Mersmann *et al.*, 2011) to prevent additional cuing. In cases where the owner's interaction with that owner's pet is a crucial aspect of the experiment, the owner is often given clear instructions in terms of how they should and should not interact with their dog during the experiment (e.g. Marshall-Pescini *et al.*, 2008; Topál *et al.*, 1997), and some experimental protocols have included exclusion criteria in case owners failed to follow these instructions (e.g. Pongrácz *et al.*, 2001, 2008; Range *et al.*, 2008; Szetei *et al.*, 2003).

*Nonsocial odor cues:* Dog's keen sense of smell has resulted in many experimenters attempting to control for inadvertent nonsocial odor cues during training and trials. In experiments where a dog searches for a hidden object from multiple possible locations, investigators have used a variety of strategies to control for odor cues; examples include smearing remnants of the food on all possible food sites (e.g. Milgram *et al.*, 1994; Tapp, Siwak, Estrada, Holowachuk, *et al.*, 2003), making sure all containers have come in contact with the food reward (e.g. Riedel *et al.*, 2008), and creating inaccessible compartments so that food could be loaded into all search locations, but only accessible at the target location (Ashton & De Lillo, 2011; Gagnon & Doré, 1992; Macpherson & Roberts, 2010). Other experimenters have removed reward scent cues altogether by developing protocols so that the food is only delivered to the dog after it has selected a container (e.g. Udell, Dorey, *et al.*, 2008a). In spatial memory tasks, where the dog is asked to search previously visited food sites, some researchers have replaced the previously baited containers with identical containers with no food in them so that odor cues could not facilitate the second search (e.g. Fujita *et al.*, 2012) or they have wiped down indoor paths in between trials to limit the use of odor cues from the initial search (Craig *et al.*, 2012).

*Motivation:* Just because an individual animal is capable of solving a task does not mean the animal will do so. Thus, dog cognition researchers often look

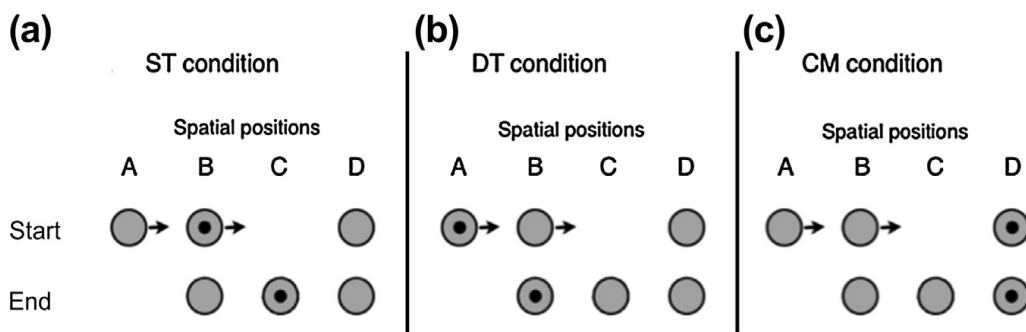


to measure whether subjects are motivated to participate in an experiment. One strategy researchers have used to check whether subjects are willing to interact with a toy or food reward, and therefore appropriate for study, has been to conduct “warm-up” trials in which the dog is given repeated occasions in which it is allowed to freely approach a food reward or fetch a toy (Kis et al., 2012; Kubinyi, Miklósi, Topál & Csányi, 2003; Kubinyi, Topál, et al., 2003; Mersmann et al., 2011; Pongrácz et al., 2012; Udell et al., 2010a). Only dogs that eat or fetch the reward repeatedly on these trials are included in these studies. Also, in a number of studies, owners were asked to fast their dogs (typically for a minimum of 4 h) before testing, so that all the dogs, in theory at least, have similar levels of food motivation (e.g. Marshall-Pescini et al., 2012; Marshall-Pescini, Praoto-Previde, et al., 2011b; Miller et al., 2010; Miller et al., 2009a). Exclusion criteria are also often written into experimental protocols, so that dogs that lose interest over the course of the experiment can either be given a break or be dropped from the study (e.g. Udell et al., 2008b). Researchers have also checked their data in a posthoc fashion to understand motivation over multiple trials in their experiments, by analyzing indicators of decreased motivation such as increased latencies of dogs to initiate a choice, and/or to begin to interact with the test apparatus (e.g. Range, Möslinger, et al., 2012).

and Doré (1992) analyzed their data for learning effects, dogs may have been spontaneously utilizing environmental cues that could have resulted in better than chance performance. For example, dogs could have immediately begun searching the screen that the displacement tool first visited, or visited the screen the displacement tool was adjacent to since it was often placed next to the correct location while the dog was allowed to make its choice. If dogs showed this preference on the first test trials, the above chance performance could be achieved without the need for mental representation of the invisible displacement, and there would be no evidence of learning. Therefore, instead of analyzing performance over a number of sessions, Collier-Baker et al. (2004) instead created control conditions in which they varied which location the displacement tool visited first and last while the target object was being “hidden” and also randomized which location the displacement tool was placed adjacent to after the target object was hidden and before the dog was allowed to make a choice. The results of these control trials did not reveal any influence of inadvertent cues from the experimenter. However, Collier-Baker et al. (2004) found that dogs used a simple associative rule of “go to the location next to the displacement tool” and that this explained the variation in performance across all other control

trials. To further test their idea more trials were run, but this time the displacement tool was placed behind the experimenter, away from the hiding locations. On these trials [Collier-Baker et al. \(2004\)](#) found that many times dogs did not make any location choice at all, but either approached the experimenter or went around to the displacement tool. This strong associative effect of the displacement tool's location has since been replicated ([Fiset & LeBlanc, 2007](#)).

Researchers have also used a spatial transposition task to investigate whether dogs are capable of Stage 6 comprehension of object permanence, which involves placing a target object inside one of multiple displacement objects (e.g. screen or box). There are more potential spatial locations for the displacement objects than there are actual displacement objects (e.g. 4 potential locations for 3 displacement objects), and while the target object remains with a single displacement object, the experimenter manipulates the position of the displacement objects ([Fig. 5.3](#)). This task is thought to be easier than the traditional Piagetian invisible displacement task, because the subject has watched the target object being hidden, and the target object remains with its original displacement object ([Doré et al., 1996](#)). Researchers have found that success on spatial transposition tasks is dependent on the transposition conditions used. Dogs will locate the target object significantly above chance levels during trials, but only when the target displacement object has been moved and no other object has been moved



**Figure 5.3** Illustration of example trials used in spatial transposition tasks. The positions of the potential displacement objects (gray circles) and the target object (small black circle) are shown before and after manipulation. Arrows depict the movement during the displacement manipulation. (a) In the substitution (ST) condition the initial position of the target object is replaced by another potential displacement object. (b) In the double transposition (DT) condition the initial position of the target object is empty after the manipulation. (c) In the control of movement (CM) condition the target object does not move. (From [Fiset and Plourde \(2012\)](#); reprinted with permission of the American Psychological Association.)

into its place. If as part of the transposition manipulation another displacement object replaces the target displacement object at its original location (Fig. 5.3a), dogs will tend to search the replacement displacement object (Doré et al., 1996; Fiset, Gagnon, & Beaulieu, 2000; Fiset & Plourde, 2012; Rooijackers et al., 2009; see similar results using a spatial rotation task: Miller et al., 2009). Thus, unless there is no longer a displacement object at the original hiding location, dogs will ignore spatial transpositions and search the exact location at which they saw the target object hidden. Overall, this is further evidence against dogs using mental representations to infer the invisible displacement of hidden objects, and instead supports the idea that dogs have a strong tendency to use associative learning and spatial cues to locate hidden objects (See Section 4.1.7.1).

*Object permanence synthesis and future directions:* Object permanence research has definitively demonstrated that dogs can follow visible displacement tasks and therefore understand that objects in their environment still exist even once they have left the dog's immediate perceptual field. However, earlier claims that dogs can infer unperceived movements and therefore understand invisible displacement now seem premature, and instead appear to best be explained by alternative search strategies based on associative learning and environmental cues. It is currently unclear whether the inability to perform well on invisible displacement tasks when associative cues are controlled for is due to cognitive constraints or simply a preference for using a combination of associative and spatial strategies that result in partial reinforcement schedules on more difficult tasks (for an example from the primate literature, see de Blois, Novak, & Bond, 1999). Attempting to disentangle strategy choice versus cognitive constraint is an outstanding issue relevant to animal cognition in general, and could be an especially fruitful area of future research on object permanence in dogs.

Related to this topic, a further potentially fruitful area of future work on dogs' object permanence abilities would be to determine whether some dogs are more prone than others to using particular cognitive strategies (see also Section 5). In addition to the idea that natural variation in understanding object permanence exists, it is possible that differences in performance between individuals are due to individual strategy preferences (e.g. some dogs choose to use associative learning combined with spatial cues while others use inferential reasoning). Theory and models of individual specializations are currently being developed in other fields, (e.g. ecology and evolution, see Dall, Bell, Bolnick, & Ratnieks, 2012), and similar theoretical frameworks may be useful for dog cognition researchers.

### 4.1.3. *Object Learning*

Research on object permanence indicates that dogs are capable of creating mental representations of objects in their environment. In an extension of this work, research on object learning in dogs has begun to ask how dogs build mental representations of objects, including social actors, and use associative learning to integrate different characteristics of the same object (Domjan, 2005). Recently, canine researchers have modified methods originally developed for research on preverbal human infants to investigate object learning in dogs.

Adachi, Kuwahata, and Fujita (2007) used a violation expectancy procedure adapted from habituation procedures developed for infant children to measure how both visual and auditory cues may contribute to a dog's mental representation of an object. Previous research had found that human infants would orient longer toward an unexpected stimulus when compared to an expected one (Baillargeon, 1987). Adachi *et al.* (2007) used this same paradigm to measure how dogs use auditory information to formulate expectations regarding the visual aspects of a social stimulus (their owners and strangers). Using audio playback the experimenters presented audio recordings of either the dog's owner or a stranger repeatedly calling the dog's name. After the final call, a photo of either the owner's face or a stranger's face was immediately presented using an LCD video monitor. Dogs looked significantly longer when the image contradicted the auditory stimulus, suggesting that dogs may create expectations of visual events based on auditory information alone.

Evidence of dogs combining both visual and auditory information in their mental representations of social stimuli has also been found by using other dogs as the target. Dogs have been shown to distinguish between barks and growls based on context (Farágó, Pongrácz, Range, Virányi, & Miklósi, 2010; Maros *et al.*, 2008) as well as the individual producing the barks (Molnár, Pongrácz, Farágó, Dóka, & Miklósi, 2009). Farágó, Pongrácz, Miklósi, *et al.* (2010) were interested in investigating whether, after hearing a growl, dogs might create a mental representation of what the growl-producing dog should look like. After doing an audio playback of a growl, dogs were shown two pictures of the same dog. One picture was the actual size while the other was edited to either be 30% smaller or larger than the life-sized dog. Farágó, Pongrácz, Miklósi, *et al.* (2010) found that subjects showed a matching preference (i.e. looked at first and looked at longer) for the actual size of the target dog based on the sound of the growl. Both this study and the one conducted by Adachi *et al.* (2007) illustrate the importance of taking a multisensory modality approach toward object learning in dogs.

Object learning research has also demonstrated that dogs have a concept of the physical properties of objects, which are incorporated in the dog's mental representations of these objects (e.g. object solidity, size constancy; Kunder, Los Reyes, Taglang, Baruch, & German, 2010; Pattison, Miller, Rayburn-Reeves, & Zentall, 2010). Recently, this type of research has also garnered evidence of potential sex differences in cognition. Müller et al. (2011) found stark differences between how male and female dogs responded to a violation of size constancy. Females looked significantly longer when the size of a rolling ball seemed to “magically” change after rolling temporarily behind a barrier while males did not. This study appears to be the first demonstration of sex differences in canine cognition; further studies on the subject are needed to test the generalizability of the effect.

There is some evidence that dogs may incorporate gravity in their use of mental representations to track moving objects, or at least have an expectation that dropped hidden objects may reappear on the ground below the place where they were dropped. Osthaus, Slater, and Lea (2003) observed the search behavior of dogs for dropped objects and dogs' understanding of the physical mechanisms of opaque connecting tubes. Dogs, like infants and some primates, appeared to show a strong bias initially searching for the reward directly under where they saw it being dropped. Dogs did not show an intuitive understanding (i.e. on their initial searches) that the tubes could divert the reward's trajectory, but were able to learn that certain drop locations resulted in finding locations that “defied gravity” over a number of trials. This sort of flexibility is not seen in young human toddlers (Hood, 1995).

A number of authors have pointed out the need for studies on how olfactory stimuli are integrated into mental representations (Adachi, 2009; Pattison et al., 2010; Rooijackers et al., 2009). Gazit et al. (2005a) found some evidence that dogs use olfactory cues to develop expectations about hidden objects. In their experiment, Gazit et al. (2005a) tested purpose-bred working-dogs on their ability to find multiple hidden targets consisting of three unique explosive odor signatures (C4, TNT, and PETN). On average, dogs were highly successful at finding hidden locations of all three of the odor types (baseline detection rates >80%) but the dog's lowest baseline performance was with TNT. Gazit et al. (2005a) then gave repeated search trials using only TNT. After these trials the other two scent targets were reintroduced, and searches were again performed with multiple target scents, but the proportions of TNT targets placed were manipulated. After TNT-priming trials, search efficiency for TNT improved significantly, but only on trials where the probability of finding TNT remained high,

suggesting that dogs created expectations based on previous TNT encounters (see also Bond & Kamil, 1999).

*Object learning synthesis and future directions:* The research reviewed in this section suggests that dogs create mental representations of objects (including social “objects” such as individual humans or conspecifics) using multiple sensory modalities. Future research on the saliency of different sensory modalities used to form mental representations of objects, given a particular set of environmental circumstances, should yield useful insights. Examination of potential sex-specific cognitive processing and differences between the sexes in object learning needs further investigation. Almost any canine research that incorporates nonvisual cues (particularly olfactory cues) and how dogs integrate these cues into mental representations of objects would be welcome.

#### **4.1.4. Categorization/Inferential Reasoning**

Researchers have recently begun to explore how dogs are able to categorize both natural and arbitrary stimuli, including human language, using inferential reasoning. These studies help develop an understanding of how dogs perceive and organize the world around them as well as provide evidence of complex cognitive mechanisms (e.g. abstract classifications) affecting canine behavior. As an example of using “natural” categories, early work (Heffner, 1975) demonstrated that dogs have the ability to categorize auditory stimuli based on their source (i.e. dog versus nondog). More recently, researchers have used touch-screen technology and forced two-choice procedures to investigate categorization of natural visual stimuli. Range, Aust, Steurer, and Huber (2008) presented four subject dogs with pictures of dogs and landscapes simultaneously. Selecting the dog images (the subjects pressed either the left- or right side of a touchscreen with their muzzle) was rewarded while selecting the landscape images resulted in a 3-s delay “penalty” and no reward. The dogs successfully distinguished between the two classes of images, and showed successful transfer to novel images in those classes. Thus, Range *et al.* (2008) demonstrated that the dogs were using a category-specific strategy, meaning that the dogs were responding to the inclusion or exclusion of multiple features common in the “dog” class, and were not simply building stimuli-specific associations (i.e. learning that particular dog images resulted in a reward). Interestingly, while the subject dogs appeared to make distinctions that matched the classes defined by Range *et al.* (2008), it is possible that the dogs may have simply used discriminating stimuli that correlated with the presence of a dog and not with a landscape (e.g. “eyes” versus “no eyes”, or “fur” versus “no

fur”, “mammal” versus “not mammal”, “quadruped” versus “not quadruped”, etc.) or vice-versa. There is a considerable amount of research investigating the categorization of natural groups in other nonhuman animals, particularly pigeons, which provide evidence of these animals utilizing alternative categorization strategies (e.g. Aust & Huber, 2001; Cook, Wright, & Drachman, 2012; Loidolt, Aust, Meran, & Huber, 2003). Research on salient cues that dogs use (i.e. size versus shape) to generalize a label to multiple objects should begin to provide insight into how dogs might categorize their world and use inferential reasoning (van der Zee, Zulch, & Mills, 2012).

Aust et al. (2008) used arbitrarily defined classes in a comparative study of human, pigeon, and dog subjects, to test the abilities of all three species to use inferential reasoning by way of exclusion. During the training phase of this experiment, positive stimuli (S+) and negative stimuli (S-) objects were established by presenting a pair of images of arbitrary items on a screen (e.g. such as a red briefcase [S+] versus a green clock [S-]) and the subject was either rewarded or timed out depending on which object was selected. Once the subject met the training criterion, a novel arbitrary stimulus was presented along with a previously learned S- one; in this case, the subject should select the novel item if using inferential reasoning. Controls were used to test whether selection of the novel object was actually due to inferential reasoning, or other possible explanations such as neophilia (see Kaulfuss & Mills, 2008) or S- avoidance.

Of the six dogs tested, three showed a preference for the novel object, and the control trials indicated that these three dogs were utilizing inferential reasoning. Interestingly, the three dogs that showed a preference for the novel object were actually the slowest to reach criterion during the training phase, which only required the learning of basic stimulus-response associations. Several themes emerge from the Aust et al. (2008) study: (1) small sample sizes resulted in interesting but potentially difficult to interpret results (half the dogs demonstrated inferential reasoning, half did not), and (2) results seem to indicate correlated cognitive characteristics. We refer to these themes throughout our article, but needless to say research on possible tradeoffs in dogs' cognitive abilities and/or strategy preferences using categorization/inferential reasoning paradigms should prove fruitful (see Section 5).

#### 4.1.4.1. Understanding Language

Evidence of inferential reasoning has also been critical to spurring categorization research focusing on basic language-learning abilities in dogs. Most

notably, Kaminski, Call, and Fischer (2004) researched the word-learning abilities of a border collie named Rico, and documented his knowledge of over 200 proper nouns. Kaminski *et al.* (2004) were particularly interested in Rico's ability to increase his vocabulary via "fast-mapping", which is a cognitive mechanism used by children whereby a subject quickly learns the label for a novel object through reasoning by way of exclusion (Dollaghan, 1985). The experimenters placed a novel item among a group of items already known to Rico and found that Rico would successfully retrieve the novel item when the novel name was used during retrieve commands. The assumption made was that Rico, knowing the names of all the other items, was able to exclude these as options for matching the previously unheard name and thus reasoned that the owner was referring to the novel object. During retention tests, Rico correctly performed retrieval of the novel item 4 weeks later.

Kaminski *et al.* (2004) hypothesized that three separate required cognitive steps were necessary for Rico's behavior: (1) through training Rico had learned that items have labels; (2) using exclusion principles Rico is able to attach novel labels to novel items; and (3) Rico has the ability to then store knowledge of new labels into memory. Kaminski *et al.* (2004) concluded that Rico's demonstration of these steps is evidence that at least some of the crucial components that make up humans' complex language abilities are possessed by dogs.

However, other authors have questioned Kaminski *et al.* (2004) conclusions (see Bloom, 2004; Markman & Abelev, 2004). In response, Fischer, Call, and Kaminski (2004) clarified their methodological procedures. For example, Markman and Abelev (2004) highlighted the possibility that Rico's performance on the novel-item tasks could be explained by neophilia (preference for novel stimuli), which has been shown to affect canine behavior (Kaulfuss & Mills, 2008). Fischer *et al.* (2004) noted that during the trial sets where Rico was asked to retrieve novel items, the owners had previously asked Rico to retrieve known items first. Thus, if indeed neophilia was influencing Rico's choices, he at least demonstrated an ability to inhibit any novelty preferences to accomplish the requested tasks.

Bloom (2004) also cautioned against attributing human-like linguistic skills to dogs solely based on Rico's performance, pointing to some key differences that may exist between the skills Rico demonstrated to achieve such results and the linguistic elements demonstrated by human children. Specifically, Bloom (2004) argued that it had not been conclusively demonstrated that Rico had an understanding of the referential properties of words.



To illustrate his point Bloom (2004) used the phrase “bring-the-sock” as an example. If Rico did understand the referential nature of the word “sock” then he would approach the phrase similarly to a human toddler, assessing the command word “bring” and the object name “sock” separately. It is possible that Rico simply processed the phrase “bring-the-sock” as a single item/action request. Bloom (2004) also pointed out that another basic linguistic skill seen in children is the understanding of categorical labels, or common nouns, and that this ability was not demonstrated by Rico.

Pilley and Reid (2011) looked to expand upon the findings from Kaminski et al. (2004) and in addition specifically address the points brought up by Bloom (2004) by conducting research on their own border collie, Chaser. To test whether Chaser understood that words referenced objects, Pilley and Reid (2011) conducted the following experiment. Chaser was taught three separate action commands: (1) “Take,” (2) “Paw,” and (3) “Nose.” The researchers then utilized three of the objects taught to Chaser previously: (1) plastic toy lips (“lips”), (2) an ABC building block (“ABC”), and (3) a toy lamb (“lamb”). An important note is that the three commands had never before been paired with these three objects; there was no previous opportunity for Chaser to learn the combination of a command and an object as a simple one-word proposition (e.g. “paw-the-lamb”). The three actions were randomly matched with each of the three objects in 14 trials; Chaser followed the correct action command associated with the correct item in 100% of the trials, providing strong evidence that Chaser understood the referential property of words.

Using both previously learned and novel items, Pilley and Reid (2011) then used discrimination training procedures to train Chaser on novel secondary categorical names to known objects (e.g. a doll and tug toy were both categorized as a “toy,” different discs were categorized as “Frisbee”). Through three separate tests, each requiring eight successive trials involving nonreplacement retrievals (each test started with 16 items), Chaser showed evidence of a common noun understanding as she successfully retrieved 100% of the items that fell within the requested category. Chaser also showed an ability to generalize common nouns as she retrieved objects that belonged to the requested category, but had not been used during the training phase of this experiment. In sum, these results provide strong evidence of at least one dog demonstrating an understanding of the referential properties of nouns, similar to the abilities detected in young children (Baldwin, 1993; Carey & Bartlett, 1978). Pilley and Reid (2011) also demonstrated that Rico’s object vocabulary of over 200 proper nouns did not represent

the cognitive load limit for dogs; Chaser was shown to learn over 1000 words.

In 2012 three more studies replicated and extended work on dog word learning. Using a 12-year old Yorkshire terrier named Bailey, [Griebel and Oller \(2012\)](#) demonstrated that the ability to learn large proper noun vocabularies is not limited to border collies. Bailey could also generalize labels voiced by novel people. [Ramos and Ades \(2012\)](#) showed that a trained mongrel dog named Sofia was able to respond correctly to different combinations of object and action words, and continued to perform well even when the order of the words was reversed. Finally, [van der Zee et al. \(2012\)](#) provided more evidence of dogs being able to learn referential labels for categories of objects and apply these labels to novel objects, though the border collie tested in their study (Gable) appeared to initially generalize objects based on size as opposed to based on shape, the pattern more typically seen in humans ([Landau, Smith, & Jones, 1988](#)).

One additional note should be made. [Griebel and Oller \(2012\)](#) reported that Bailey was not successful on the reasoning by exclusion trials similar to those used with Rico, and thus did not show evidence of “fast-mapping.” [Griebel and Oller \(2012\)](#) did note that potential breed and age differences may have explained some of the differences in results (Bailey was 12 years old; Rico was 8 years old, and Chaser was around 4 years old), and also argued that stronger evidence of “fast-mapping” could be provided by discrimination trials in which two or more newly learned items are placed next to each other and requested individually. Future studies on learning by exclusion in dogs should provide more clarity in language learning studies.

#### 4.1.4.2. Creating Language

In the only known study in canines on the subject to date, [Rossi and Ades \(2008\)](#) studied how word-learning might be incorporated into novel communication production in dogs. Dogs show a unique sensitivity to receive communicative signals from humans, but also provide communication to others through vocalizations and body language ([Elgier, Jakovcevic, Barrera, Mustaca, & Bentosela, 2009](#); [Kubinyi, Virányi, & Miklósi, 2007](#)). [Rossi and Ades \(2008\)](#) tested whether the first author’s pet mongrel dog Sofia could learn to use a novel computer keyboard system (with the keys being distinguished by arbitrarily assigned lexigrams) to produce communicative information soliciting different types of rewards or actions from humans.

Starting when Sofia was a puppy, and after working on basic training commands, [Rossi and Ades \(2008\)](#) began incorporating the arbitrarily

assigned lexigrams into behavioral sequences involving rewarding acts. For example, throughout her life, before being given access to food, Sofia was asked to “paw” at the lexigram button associated with food. The individual lexigrams were initially placed near the target objects, but over time the distance was increased until all the lexigrams were placed on a single electronic playback keyboard. Now when Sofia pressed a key, the corresponding auditory word for the request was also emitted. Thus, pressing on the corresponding keys became integrated into the behavioral sequences necessary for Sofia to acquire rewarding objects/acts.

During test trials Sofia would either initiate requests on her own, or sometimes the experimenter would bring out desirable objects and see how she would respond. Sofia's behavior immediately before and after she interacted with the keyboard was coded as a way of determining the communicative intentionality of her behavior. The behaviors coded included direction-based behaviors, such as looking at potential targets, as well as nondirected behaviors such as locomotion, tail wagging, and vocalizations. Analyses found high correspondence between Sofia's physical movements, her vocalizations, and the lexigrams activated. In other words, Sofia's actions were directed toward the objects associated with the selected lexigram. This suggests that Sofia was able to discriminate between the potential keys and correctly activate the keys corresponding to the outcomes that corresponded with her natural soliciting behaviors. Rossi and Ades (2008) also made note of evidence of Sofia generalizing the key requests to categories of objects. For example, Sofia used the “Toy” key to request a wide range of toys and the “Crate” key to gain access to additional resting areas. This acts as further evidence of dogs showing an understanding that objects can be categorized into larger common groups.

It is possible that Sofia's performance may simply be due to associative learning, which would require no intention of communication to the experimenter. However, Rossi and Ades (2008) argued that qualitative analysis of Sofia's behavior indicates communicative purpose. First, when left with the keyboard alone Sofia never interacted with it, though it is possible that through training the experimenter's presence became a discriminatory stimulus. Second, Sofia's alternating glances back and forth between the experimenter and the goal objects were similar to behaviors that have been previously interpreted as communicative intention in dogs (Miklósi, Polgárdi, Topál, & Csányi, 2000). Finally, Rossi and Ades (2008) noted that Sofia's response when the experimenter's response was delayed or did not respond correctly was to repeat the “request” by reactivating the same key.

While further studies are needed, it appears that Rossi and Ades (2008) successfully taught Sofia to produce communicative information to solicit different rewards, and that Sofia had learned to use the keyboard as a substitute or to facilitate natural soliciting behaviors.

*Categorization/inferential reasoning synthesis and future directions:* The studies reviewed here demonstrate the ability of dogs to categorize objects in the environment and, in some cases, use inferential reasoning to categorize novel objects. Unfortunately, the features which dogs utilize to define categories are largely unknown; paradigms used in other taxa (e.g. Aust & Huber, 2001; Cook *et al.*, 2012; Loidolt *et al.*, 2003) should provide useful starting points for future categorization work. Notably, a recent study using new technology to track visual attention in dogs may provide new methods for understanding how dogs categorize visual data (Somppi, Törnqvist, Hänninen, Krause, & Vainio, 2012). When shown images of dogs, humans, toys, and the alphabet, Somppi *et al.* (2012) found that dogs fixated their gaze most often on the dog pictures, and fixated more on human images than those of inanimate objects (see Téglás, Gergely, Kupán, Miklósi, & Topál, (2012) for an example of experimenters using visual tracking in a social cognition study). Additionally, further research is needed to investigate how dogs categorize nonvisual stimuli such as sound and scent, as well as how factors such as dog age, sex, and breed impact categorization ability.

The results obtained by Aust *et al.* (2008) also highlights the idea of cognitive tradeoffs; dogs that showed evidence of inferential reasoning were also the slowest in training trials requiring associative learning. Cognitive tradeoffs may be widespread taxonomically. For example, bees (*Bombus terrestris*) appear to face foraging speed/accuracy tradeoffs; some workers visit a greater number of flowers than others, but sample flowers that do not yield high pollen loads. Worker bees that visit fewer flowers often carry higher pollen loads (Burns, 2005; Chittka, Dyer, Bock, & Dornhaus, 2003). We return to cognitive tradeoffs, constraints, and individual strategy preferences in greater detail later (Section 5).

Language-learning studies seem to indicate that at least some dogs possess cognitive elements critical to the development of complex language. Such results are important in their own right but also contribute to our knowledge of the evolution complex social skill sets. However, due to their labor-intensive design and the experimenters' typical aims (determine the potential upper-limits of cognitive language processes in a small sample of exceptional dogs), sample sizes in studies on language-learning and language-creation have been small. Understanding how dogs categorize

human words relevant for work or companionship seems central to utilization of dogs in human society, and future studies will need larger sample sizes to allow for inference to dog populations in general. Future research could focus on developing test paradigms that are logistically feasible and relevant to dogs' utility in human society. Finally, putative "fast mapping" cognitive processes in dogs require further investigation.

#### **4.1.5. Object Manipulation**


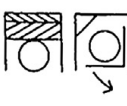
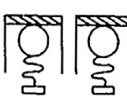
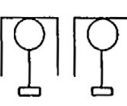
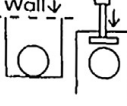





Measuring how dogs learn to problem-solve through object manipulations has been a part of animal intelligence research since its inception. Along with his work on cats, Thorndike (1911) also used dogs in his famous puzzle boxes (Feuerbacher & Wynne, 2011), and since then studies that use object manipulation paradigms in dogs have become central to three areas of comparative cognition. First, in the context of measuring independent problem-solving skills, manipulation tasks have been used as the basis for inter- and intraspecific comparisons of canine intelligence (e.g. Frank & Frank, 1985; Hiestand, 2011). Second, object manipulation has been analyzed to examine whether dogs are able to understand means-end relationships, as opposed to simply learning to manipulate objects through trial-and-error learning. An understanding of means-end relationships is a prerequisite for problem-solving employing insight, and is likely a precursor to tool use, another popular topic in comparative cognition (Shettleworth, 2010). Third, object manipulation paradigms have been utilized to investigate the types of social learning mechanisms dogs use, as well as the elements and contexts that facilitate social learning (e.g. Kubinyi, Topál, Miklósi, & Csányi, 2003; Miller, Rayburn-Reeves, & Zentall, 2009a; see Section 4.3.4).

##### **4.1.5.1. Independent Problem-Solving**

Frank (1980) hypothesized that natural selection had favored cognitive processing in wolves that improved their general independent problem-solving abilities, while artificial selection through domestication had favored cognitive traits in domestic dogs that were conducive toward working cooperatively with humans. Frank (1980) also argued that in domestic dogs, selection pressures were relaxed relative to ongoing selection pressures in wolves, resulting in an overall decrease in independent problem-solving abilities in dogs and subsequent increases in independent problem-solving performance variability (Frank, 2011; Frank & Frank, 1985). Finally, Frank (1980) hypothesized that dogs would perform better than wolves on training tasks involving cues that are arbitrarily assigned (e.g. verbal cues) and where

the required behavior does not provide direct access to the goal reward (e.g. inhibiting locomotion to receive a food reward from an external source, such as a handler).

In one of their first experiments to test wolves versus dogs in their ability to problem-solve independently using a manipulation task, Frank and Frank (1985) used a number of increasingly difficult tasks to measure performance of canine subjects on manipulating a box to gain access to a food dish (Fig. 5.4; see Scott & Fuller (1965) for a similar design). The increasing difficulty of the various box setups corresponded with solution strategies that would be indicative of different stages of Piaget's model of sensorimotor

Day	1	2		3		4		5		
Trial	Preliminary (P)	T <sub>1</sub>	T <sub>2</sub>	T <sub>3</sub>	T <sub>1</sub>	T <sub>2</sub>	T <sub>3</sub>	T <sub>1</sub>	T <sub>2</sub>	T <sub>3</sub>
Task	 Box 1	 Box 1 Box 2		 Box 1 Box 1		 Box 1 Box 1		 Box 3 Box 4		
No. Of Solutions										
Wolves; (n=4)	4	4	3	3	4	4	3	4	3	1
Malamutes; (n=4)	2	3	2	1	4	1	0	4	0	0
Key:  Box  3/2" Block  1 3/4" Block  String & dowel  Food dish										

**Figure 5.4** Illustration of different manipulation tasks used in Frank and Frank (1985) and the number of subject wolves and malamutes that solved each task. The illustrations in the task row are top-down views of the different tasks used for each trial on each day of this study. On day 1 the subjects were given a preliminary (P) task in which the food dish was simply placed just inside the box. Two thick blocks prevented the bowl from being pushed further inside the box (a P task was given on the first trial of all subsequent test days). On day 2, trial 2, one of the blocks was thinner so that the food dish could be pushed further into the box, and on trial 3 the subjects had to rotate a revolving door in order to access the food dish. On day 3, trials 2 and 3 required the subjects pulling on a string to gain access to the food dish. A thin block was placed in the back of the box to prevent the food dish from going all the way back. On day 4, trials 2 and 3 were similar to those on day 3 except there was no block and so the dish was further back. On day 5, trial 2 subjects needed to push the box away from the wall, and on trial 3 the food dish was obtained by pushing on a plunger at the rear of the box. (*Reprinted with permission of the American Psychological Association.*)

development (Parker & Gibson, 1977). For example, the easiest task, which was used during pretrials, was arranged so that the food dish could not be completely inserted into the box, and therefore was partially exposed. All subjects were capable of “solving” this task simply by grabbing at the edge of the bowl with their paw or mouth, requiring only prehension (Piaget’s 3rd stage of sensorimotor development). However, other box variations, such as one that required rotating a gate that covered the box opening to access the food dish was argued to require “complex object manipulation,” though the researchers admitted it was subject to various interpretations (such motor skills would be indicative of Stage 5 development in Piaget’s model). Due to the required behaviors being functionally linked to the end goal, Frank’s (1980) theory predicted that the wolf puppies would perform better than their malamute counterparts.

Wolf puppies in Frank and Frank’s (1985) experiment were successful at solving all variations of the puzzle boxes, suggesting a minimum Stage 5 level of sensorimotor development. Malamute puppies, on the other hand, primarily solved the puzzle boxes that required only simple object manipulations, thus only demonstrating Stage 3 development. Frank and Frank (1985) also noted a number of additional qualitative differences in the cognitive approaches taken by wolf and dog puppies. Wolves were more persistent and independent; they would spend a longer time focused on gaining direct access to the food, while malamutes would tend to give up direct manipulation behaviors sooner and instead showed solicitation behaviors toward the experimenter. It was unclear from Frank and Frank (1985)’s study whether dogs were choosing to use alternative strategy preferences relative to wolves (i.e. solicitation from humans), or whether dogs clearly did not possess the ability to achieve Stage 5 sensorimotor development.

Frank and Frank (1982) examined the potential of motivation differences between dogs and wolves to independently solve tasks by measuring the performance of wolves on a barrier-detour task using both social and food rewards, and comparing their results from those obtained with dogs by Scott and Fuller (1965). Frank and Frank (1982) found that social rewards actually had more incentive value than food to wolves (up to 18 h of food deprivation), while dogs had previously shown a slight preference for the food rewards. Thus, there was no reason to conclude that the wolves were more food motivated than the dogs in Frank and Frank’s (1985) study. Frank and Frank (1985) also noted additional qualitative differences between their wolf and dog pups that suggested that their paradigm measured true differences in the two taxa in their sensorimotor development, and not that dogs

“chose” to use a soliciting strategy instead. For example, once successful the wolves were always successful on later attempts on that same puzzle or similar iterations, while the malamutes would often fail on subsequent trials (even if successful in a previous one). The malamutes would also at times become startled by the appearance of the bowl, suggesting that the rewards were fortuitous. Frank and Frank (1985) putatively concluded that dogs lack an understanding of means–end relationships (Piaget’s Stage 4).

One major caveat, also acknowledged by Frank and Frank (1985), was that their canine subjects were all 10-week old wolf cubs and puppies. It is possible that dogs do display cognitive complexity required to reach later stages of Piaget’s sensorimotor development, but not until later in life. While Frank and Frank’s (1985) puzzle box results are in need of further replication, a single follow-up study conducted by Hiestand (2011) supports the idea of dogs lacking the cognitive complexity to independently problem-solve beyond Stage 3 in Piaget’s sensorimotor framework. Hiestand (2011) compared the performance of adult and juvenile wolves with adult German shepherds on a rope-pulling task. The two adult wolves tested successfully completed all tasks, again demonstrating Stage 5 development, while of the 40 dogs tested only five were successful. Differences in training and testing procedures between species represent potential confounds but overall these findings support the idea that independent problem-solving is more variable in dogs than in wolves (Frank, 1980; Frank & Frank, 1985).

The use of independent problem-solving tasks has also been used to study the effects of training experience and human–canine bonding on an individual dog’s behavior. Topál, Miklósi, and Csányi (1997) tested whether dogs with stronger human bonds would act in a more socially dependent way (i.e. show poorer independent problem-solving skills). Their canine subjects were labeled either as having “companion–relationships” or “working–relationships” with their owners. “Companion” dogs lived inside the home and were considered close family members while “working–dogs” were kept outside, for example as guard dogs, and were not necessarily considered a member of the family. Subjects were also categorized as “trained” or “untrained” based on whether they had earned a certificate of official obedience training. Background training level was not found to impact problem-solving performance, but during the portions of trials where owners were asked to not encourage their dogs, dogs with “companion” relationships showed increased latencies to manipulate objects to gain access to food, looked more often at their owner while doing so, and accessed fewer food rewards relative to dogs with “working–relationships”. During times



when owners were allowed to encourage their dogs, companion- and working-dogs performed equally well on the problem-solving task.

Other studies have illustrated the influence of a dog's experience on its problem-solving skills. [Marshall-Pescini et al. \(2008\)](#) found that dogs that had completed training of various types (e.g. agility, schutzhund, search & rescue) were more likely to complete a puzzle box to gain access to a food reward when compared to dogs who had either just had basic obedience training or no formal training at all. The specialty-trained dogs also were found to spend more time within a 2-min period engaged with the puzzle box and spent less time performing nonpertinent behavior. [Range, Heucke, et al. \(2009\)](#) also found an overall generalized training effect on their subjects' ability to access a puzzle apparatus. In another case, [Marshall-Pescini, Passalacqua, Barnard, Valsecchi, and Prato-Previde \(2009\)](#) failed to find significant differences in performance outcomes on a "solvable" task between search & rescue, agility, and untrained pet dogs; however this finding may have been due to the apparent low level of difficulty of the manipulative task used, which simply required the subject dogs to overturn a free-standing container to retrieve a reward (34 out of 39 subjects were able to perform successfully on their first trial). Overall, it appears that background training and relationships with humans impact a dogs' subsequent independent problem-solving requiring object manipulation behavior.

#### 4.1.5.2. Means-End Tasks

The ability to contemplate how a combination of actions leads to a particular goal outcome is a crucial step in human cognitive development that allows for action planning and the ability to demonstrate insight ([Bratman, 1981](#)). In fact, an understanding of means-end relationships is best shown by the demonstration of insightful behavior to solve a novel task on the first trial ([Osthaus, Lea, & Slater, 2005](#)). Presumably, an understanding of means-end relationships, particularly as it pertains to object manipulation, is a key mental prerequisite to advanced cognitive abilities such as tool use; as a result, evaluation of means-end understanding across species is an important area for comparative cognition research (e.g. [Helme, Call, Clayton, & Emery, 2006](#); [Schuck-Paim, Borsari, & Ottoni, 2009](#)).

According to [Piaget \(1953\)](#) children at around the age of 8 months old transition from executing action patterns based on operant conditioning to beginning to understand means-end relationships (Stage 4 in Piaget's model of sensorimotor development). Early experiments designed to test dogs' abilities to understand means-end relationships typically reported negative

findings (e.g. Scott & Fuller, 1965; Shepherd, 1915; Thorndike, 1911). Unfortunately, inference from most early studies suffered from low sample sizes or methodological confounds (Osthaus *et al.*, 2005).

Osthaus *et al.* (2005) sought to remedy these issues by performing a series of experiments utilizing a variation of a string-pulling task. In their first experiment, there was only a single string available; once pulled, the subject dog gained access to a piece of food. The string length and angle were varied on different trials. All dogs learned to use the string but during trials where strings were at an angle rather than vertical many dogs showed a “proximity error” by pawing at the part of the barrier closest to the food before interacting with the string, indicating that at least some of the dogs may not have understood the means–end relationship of the string. In their second experiment, Osthaus *et al.* (2005) presented dogs with a number of conditions involving two strings, where one was attached to the food reward and one was not. Conditions varied the distance between the strings, the angle of the strings relative to the barrier, and if the strings were parallel or crossed. Through these experiments dogs continued to show a tendency to exhibit a proximity bias, first approaching the string end closest to the food reward, leading the authors to conclude that dogs did not seem to understand the means–end relationship in this task either (see also Frank & Frank, 1985). This proximity bias was replicated with dogs when both dogs and wolves were recently tested on a similar string-pulling task (Range, Möslinger, & Virányi, 2012).

However, another recent study has led to some uncertainty about the means–end understanding in dogs. Range, Hentrup, and Virányi (2011) gave dogs the option of pulling one of two wooden boards toward themselves to gain access to a reward. The “correct” board had a reward resting on top of it, while the “incorrect” board had a reward placed to the side of it; pulling on the “incorrect” board did not allow access to the reward. The dogs in this experiment as a group performed significantly above chance levels in selecting the correct board. Using this support means–end paradigm, dogs even appeared to inhibit the previously noted proximity biases, as they were able to select the correct board even when the inaccessible food lay at a closer distance.

*Object manipulation synthesis and future directions:* A variety of object manipulation tasks have been used to measure dogs’ ability to independently learn to solve problems, as well as to utilize means–end understanding. In some cases and test conditions, dogs appear to be only able to solve puzzle tasks using trial–and–error learning that incorporate simple direct

object manipulation, akin to being at Stage 3 of Piaget's sensorimotor development framework. In other cases, especially when a dog's human social bond as well as its training experience is taken into account, it appears that some dogs are able to serially organize independent problem-solving skills akin to Piaget's Stage 5 of sensorimotor development, similar to processes observed in wolves. In general, evidence supports Frank's (1980) suggestion that relaxed artificial selection pressures on the independent problem-solving skills of dogs (relative to natural selection on the same traits in wolves) has resulted in greater within-population variation in problem-solving abilities in dogs than their current wolf cousins; studies of problem-solving abilities in dogs often report large individual differences in the performance of their subjects (e.g. Range, Hentrup, et al., 2011). Means-end understanding was previously thought to be unlikely in dogs, but recent work suggests that under some conditions (such as when using support means-end test paradigms) dogs appear to be able to understand the "goal" of their work.

Future studies may attempt to understand how morphology, life history, and cognitive traits (and the correlations between them) impact an individual's ability to independently solve problems and utilize the means-end understanding. Work understanding the social and environmental influences on object manipulations in dogs is in need of replication, both within and across different standardized test procedure/paradigms. Further, future work designed to identify and track individual specializations through ontogeny with regard to object manipulation stand to contribute heavily toward our understanding of adult-dog cognitive abilities and constraints.

#### **4.1.6. Quantitative Understanding**

The ability to make quantitative distinctions between groups of objects and/or individuals has evolutionary adaptive value in a number of behavior contexts, such as foraging (Bar-Shai, Keasar, & Shmeada, 2011; Ward & Smuts, 2007) and social group dynamics (Bonanni, Natoli, Cafazzo, & Valsecchi, 2011; McComb, Packer, & Pusey, 1994). It is likely that some level of cognitive quantitative understanding exists in a large range of species; however, the exact level of understanding likely varies (Hauser, 2000). For example, in a more simplistic way, an animal may be able to make relative quantitative distinctions in which it can tell that one group of objects is more or less numerous than another. In a more complex fashion, animals would be capable of making absolute quantitative distinctions, counting and developing mental representations of numbers.

Previous research has demonstrated that dogs can clearly perceive gross quantitative differences (e.g. 10 is greater than 5) in groups of similar stimuli and make effective behavioral decisions accordingly (Bonanni *et al.*, 2011; Macpherson & Roberts, 2010; Prato-Previde, Marshall-Pescini, & Valsecchi, 2008; Ward & Smuts, 2007; West & Young, 2002). What is less clear is whether dogs are capable of making absolute quantitative distinctions (e.g. know that 4 is 1 more than 3), and if so, whether there are limits to absolute quantitative understanding. West and Young (2002) found that dogs are seemingly able to account for an exact small number of objects. Using a violation of expectation paradigm similar to ones mentioned previously (see Section 4.1.3), West and Young (2002) measured their dog subjects' understanding of the basic math equation  $1 + 1 = 2$ . For all test trials, the dogs witnessed the hiding of two bones behind a single barrier. However, depending on the condition, when the barrier was lowered, the dogs would either find 1, 2, or 3 bones. The dogs would look significantly longer at the condition outcome when an "unexpected" number of bones (i.e. 1 or 3) were revealed, indicating that the dogs seemed to be expecting to find exactly 2 bones. West and Young (2002) did not assume that the dogs possess the same counting abilities found in humans and even other primates, however, their results would indicate that the dogs' cognitive abilities result in similar outcome expectancies, at least with regard to small counts.

Ward and Smuts (2007) examined quantity discrimination in dogs in a foraging context. Their experiment evaluated the ability of dogs to discriminate and choose between two food sources which contained combinations of 1–5 items. Weber's law (Dehaene, Dehaene-Lambertz, & Cohen, 1998; Gallistel & Gelman, 2000) states that two magnitudes are easier to discriminate between when the ratio of the smaller count divided by the larger count decreases. Ward and Smuts (2007) found that subject dogs tended to choose the larger number of food items amongst all quantity combinations, except when the ratio difference between groups of food items was only 1. Some evidence of using mental representations for comparisons was also found through the use of time delays, in which immediate perceptive cues of quantity differences were removed during the time of choice.

Given the evidence that dogs can differentiate based on quantity, recent research has turned to investigating how quantity differences may affect decision-making behavior in dogs. Bonanni *et al.* (2011) observed quantity discrimination in dogs in a social context, by recording the confrontation dynamics between three free-ranging dog packs in Italy. Bonanni *et al.* (2011) found that dogs appear to assess the relative pack size during

intergroup conflicts and tend to make optimal decisions (again based on Weber's law) about group approach/withdrawal responses. These feral dogs seemed to have a more difficult time of assessing group size differences when both groups were larger than 4 individuals, and behaved more optimally when one group was less than 4 individuals while the other had more than 4 individuals, as would be predicted by Weber's law. However, when both groups were small the approach/withdrawal decisions seemed to be independent of ratio and more in line with absolute numbers. Taken together, these results seem to provide evidence of dogs being able to use absolute quantities with small numbers and relying on relative quantity ratios when dealing with larger counts.

Within an appetitive context, beyond showing a preference for more numerous rewards, little is known about how dogs incorporate perceived quantity differences, such as how reward quantity differences impact choice behaviors related to time and effort (for examples from other species, see birds: Vick, Bovet, & Anderson, 2010; primates: Addessi, Paglieri, & Focaroli, 2011; rodents: Shafei, Gray, Viau, & Floresco, 2012). Leonardi, Vick, and Dufour (2012) measured delay of gratification behavior in dogs using a delay-exchange paradigm. The dogs in this study were trained how to exchange a reward item given to them for the one being held by the experimenter. One aspect of this study was to measure the dogs' willingness to wait for an exchange when the quantity of the exchange reward was manipulated. In general, the larger the quantity of the exchange reward (an 8:1 ratio was the largest exchange tested), the longer dogs were willing to wait out the exchange delay. More examples of how dogs and other animals incorporate numerosity into their subsequent decision-making are needed.

*Quantitative understanding synthesis and future directions:* Dogs can clearly perceive gross quantitative differences amongst groups of similar stimuli and make effective behavioral decisions accordingly. What is not as clear is whether dogs are capable of making precise distinctions between different quantities of objects, and if so, the limits of these abilities. The evidence accumulated so far seems to suggest that dogs can account for exact quantities of small groups of objects (less than 5). When numbers exceed this limit, dogs still show an ability to make quantitative distinctions on a relative basis, with decision-making improving as the discrepancy between the groups increases.

The material reviewed in this section is based on a very small number of studies, and with each exploring different aspects of numerical competence in dogs, there is clearly a strong need for further replication. In particular,

future research could aim to further extend recent findings of dogs incorporating quantity differences into decision-making processes related to the execution of specific behaviors (e.g. approach/avoid, delay of gratification). Additionally, future research should look for evidence of dogs distinguishing between different quantities using nonvisual cues, such as odor, and the factors that impact the use of a combination of different senses to estimate quantity of potential rewards, a potentially relevant topic for odor-detection dog programs.

#### **4.1.7. Spatial Cognition**

As both hunters and foragers, dogs rely heavily on spatially oriented mental mechanisms to navigate space efficiently and to track the location of hidden objects. These abilities are also crucial to a number of jobs that dogs serve (e.g. herding, patrolling, or detection). Through a variety of paradigms, researchers have investigated the ability of dogs to encode different spatial cues and the contexts in which these different cues most affect the dog's search behavior. Other studies have focused on how search strategies may differ between individual dogs and how different strategies affect search efficiency. Finally, tasks involving barriers have been found to be a successful way of evaluating spatial problem-solving capacities in dogs.

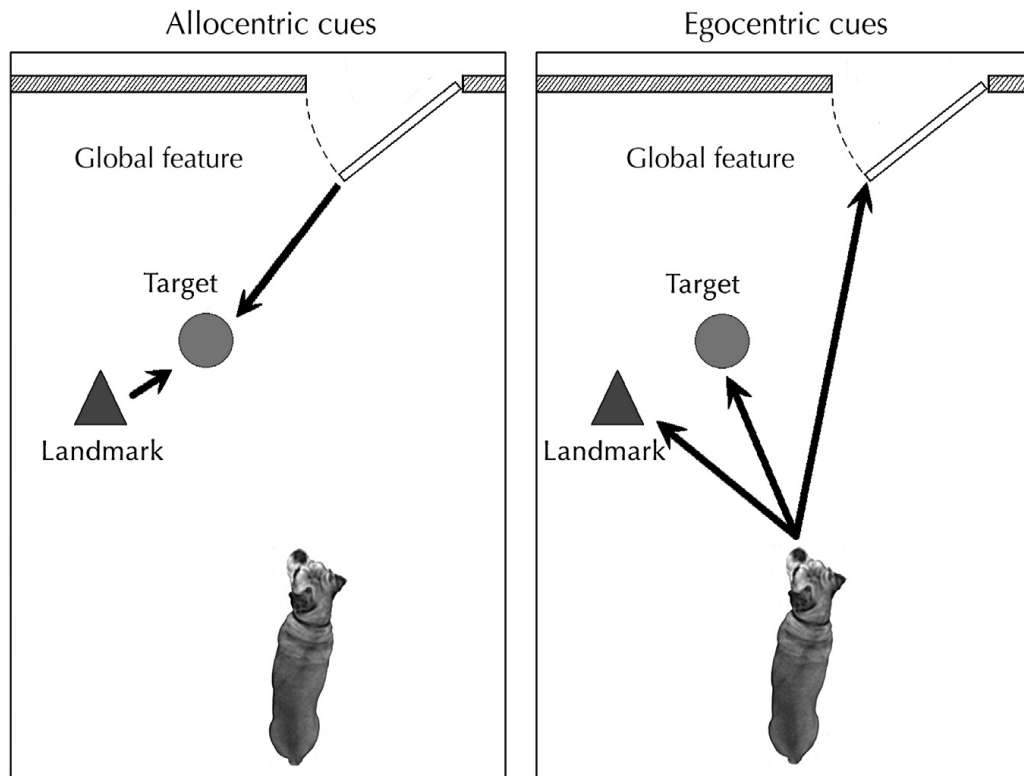
##### **4.1.7.1. Spatial Navigation**

The ability to relocate previously visited locations has adaptive significance for most animals. One way to relocate previously visited locations is to utilize the same paths that resulted in finding the locations in the first place. While following the same path is reliable and accurate, any attempts to develop novel routes, such as short cuts, would be dependent on trial-and-error learning and thus may be inefficient in terms of both time and energy. Another strategy would be to use cognitive mapping in which the animal mentally represents its current location in relation to other previously visited locations and embarks on novel efficient short cuts to find them.

Canine spatial cognitive research has found that dogs demonstrate the ability to develop novel paths based on knowledge of previously used paths (Cattet & Etienne, 2004; Séguinot, Cattet, & Benhamou, 1998). For example, Chapuis and Varlet (1987) led dogs to two separate reward sites in an open field, each time starting from the same starting location. Subject dogs were then allowed to freely search; after finding the first reward, 96% of the recorded paths between the two reward sites were classified as "short cuts," while only 1.3% of the responses followed the previously traveled paths that

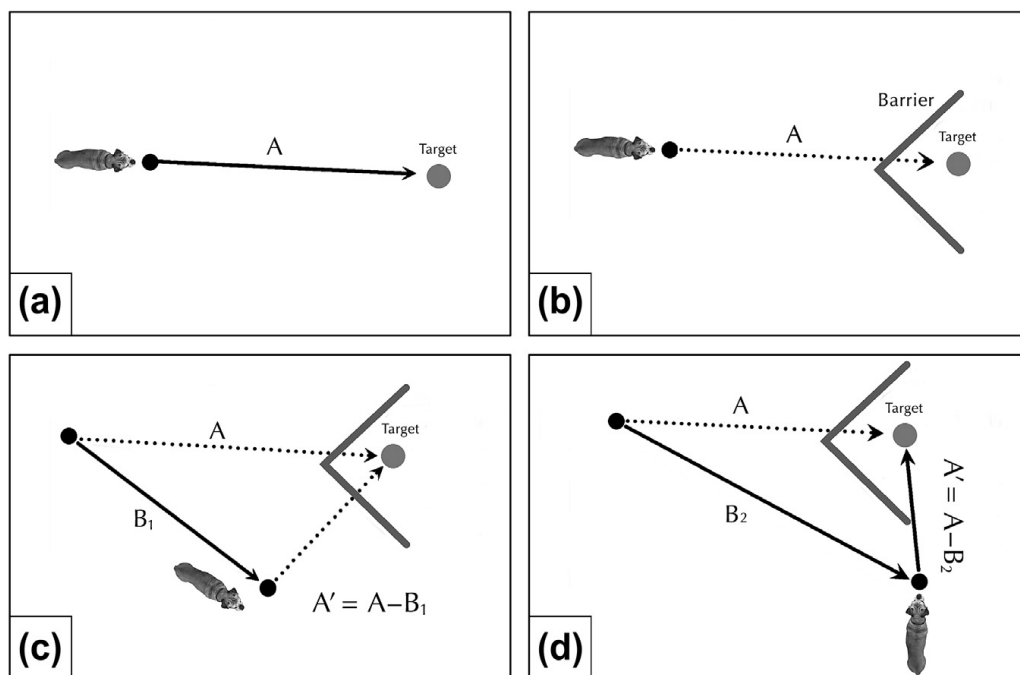
were used when initially showing the dogs the two food locations. Interestingly, [Chapuis and Varlet \(1987\)](#) also found that while 44.2% of the responses were within a 5-degree angle of a direct route to the second reward site, 36.2% of the “novel” routes intersected the initial path leading from the start point to the second location, indicating that some use of the initial path may facilitate cognitive mapping. Other studies (e.g. [Fabrigoule & Sagave, 1992](#); [Séguinot et al., 1998](#)) have provided further evidence of dogs utilizing novel shortcuts.

More recently, researchers have tested how dogs use different types of spatial cues to navigate. Allocentric spatial cues relate the goal object/location to exterior environmental stimuli. Egocentric spatial cues relate the goal object/location to the subject's own position ([Fig. 5.5](#)). Egocentric cues can be further divided into linear egocentric information or dead reckoning. Linear egocentric cues provide information about the angle and distance between the animal and its goal location. Dead reckoning (or path integration) refers to an animal using vestibular feedback indicating its own



**Figure 5.5** An illustration of the difference between egocentric and allocentric spatial cues. The left panel shows the representation of the target's position relative to the landmark and global feature (allocentric representation). The right panel illustrates the representation of the target, landmark, and global feature (e.g. room door) positions relative to the subject (egocentric representations).

direction, distance and speed of displacement relative to a goal location to accurately find the location when a direct path is not available (Cattet & Etienne, 2004; Fiset, Beaulieu, LeBlanc, & Dubé, 2007; Séguinot *et al.*, 1998; Fig. 5.6). Through the use of discrimination tasks, dogs have been found to learn reward contingencies based on both egocentric and allocentric spatial cues (Christie *et al.*, 2005; Milgram *et al.*, 1999, 2002; see Section 4.1.1). Furthermore, Christie *et al.* (2005) report specific age-related performance differences with respect to using allocentric versus egocentric cues. Older dogs ( $\geq 8$  years old) appear to perform comparably to younger dogs (6 months–5 years old) using egocentric cues to navigate, but perform significantly worse than younger dogs when the task requires the use of allocentric cues. Further studies are needed on the potential modularity of cognitive processes related to navigation that may have differential rates of development and decline.

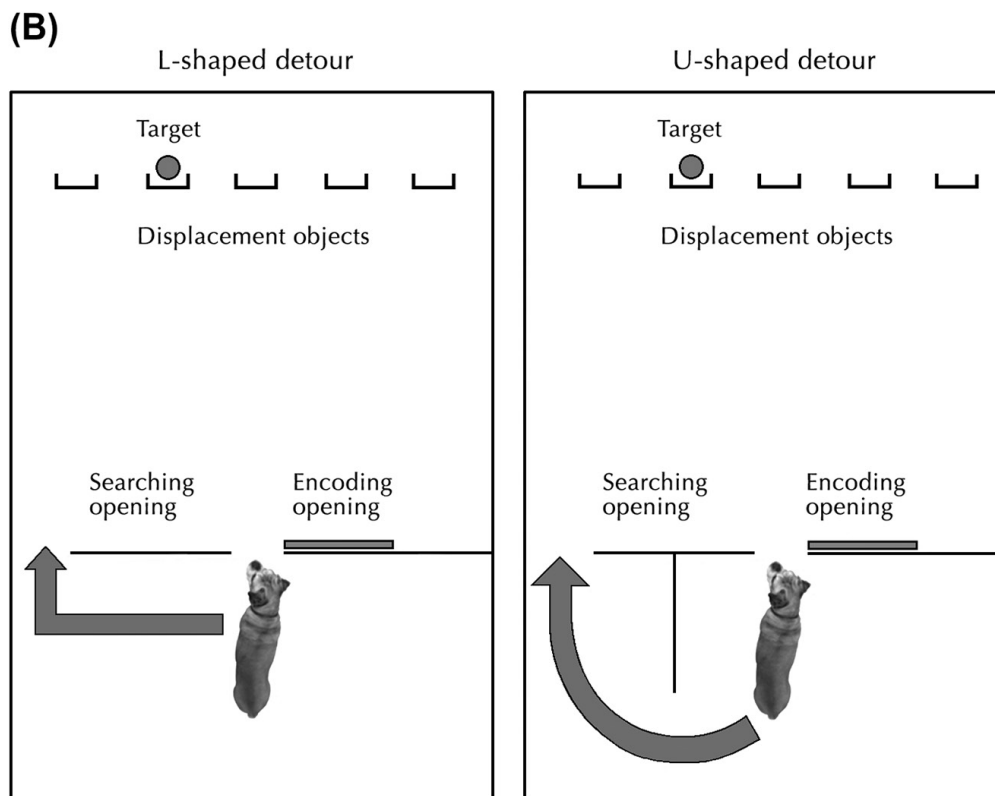
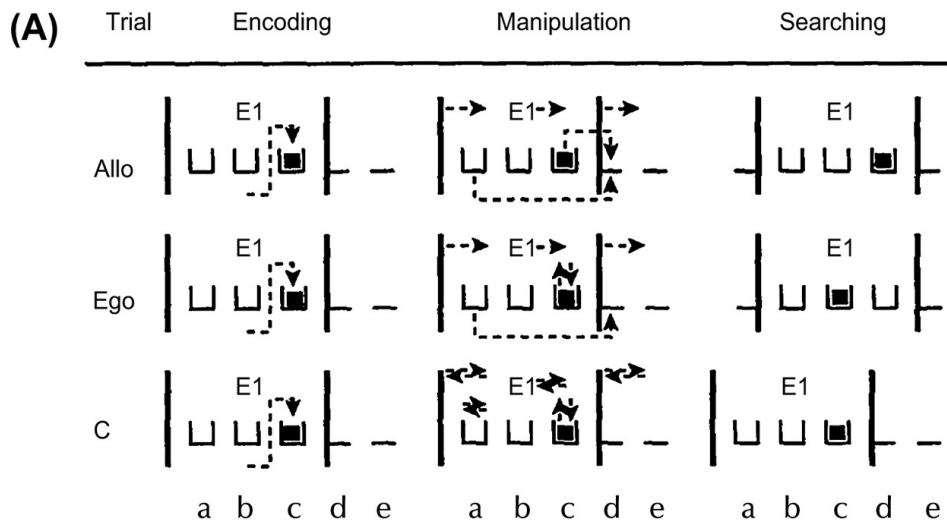


**Figure 5.6** Example of the use of path integration/dead reckoning to locate a disappearing object in a detour situation. (a) Vector  $A$  represents the direct linear relationship between the dog and the target object. (b) An opaque barrier is placed such that it prevents the dog from following the direct approach (Vector  $A$ ) and cuts off direct visual access to the target location; the dotted line represents the inability to make a direct approach. (c) Vector  $B_1$  represents the dog's displacement through space as the dog detours, continuously encoding inertial information such as direction, distance, and speed of the animal. Vector  $A'$  represents the updated egocentric linear vector that results from the detour. (d) This displacement vector is updated continuously ( $B_2$ ) as the dog moves until vector  $A'$  provides a direct visual line toward the target location.



Modifying the spatial transposition paradigm previously used to study the understanding of invisible displacement in dogs (Doré et al., 1996; see Section 4.1.2), Fiset and colleagues have conducted a number of studies examining how dogs use both egocentric and allocentric cues simultaneously while navigating within a searching context. In the original paradigm, Doré et al. (1996) placed moveable displacement objects at three out of a possible five adjacent locations. While the dog was watching, the experimenters would hide a target object behind one of the displacement objects, and as the dog continued to watch, the displacement objects would be moved laterally into new positions, and then the dog would be released to search (in this paradigm, the target object remains with the initial displacement object). Fiset et al. (2000) modified this paradigm by obstructing the dogs' view of the moving displacement objects after the initial hiding of the target object. While the dog's view was blocked, the experimenter manipulated the target object's location as well as local (the displacement objects) and global (moveable walls) allocentric cues, allowing the experimenters to measure the relative impact of these cues on the dog's subsequent search behavior (Fig. 5.7A). Fiset et al. (2000) found that dogs show a bias toward using linear egocentric cues (i.e. they approached the screen that was at the location where they witnessed the target ball being hidden) but used allocentric cues when egocentric ones were irrelevant (i.e. the trial manipulations included removing the initial hiding screen so that egocentric navigation was not a possibility). In addition, further research indicates that dogs, when encoding linear egocentric cues, rely more heavily on direction relative to distance cues (Fiset, Landry, & Ouellette, 2006).

Modifying the spatial transposition paradigm further, Fiset et al. (2007) looked to see whether egocentric cues were still utilized when a direct path was no longer possible. To access the potential reward locations the dogs now had to make either an L-shaped or U-shaped detour (See Fig. 5.7B). Under these circumstances, when both local and global environmental elements were manipulated, dogs were found to initially use both allocentric and nondirect egocentric (i.e. dead reckoning) cues equally which resulted in dogs often searching in an intermediate location (relative to where they would be expected to search if they were only using either egocentric or allocentric cues). However, some evidence for a bias toward allocentric cues was found on repeated trials with the more complex U-shaped detour. After numerous U-shaped detour trials, in which using allocentric cues would result in reward, dogs began to consistently attune to these cues. This same improvement in learning was not observed over trials where egocentric



**Figure 5.7** (A) Illustration of the experimental conditions used in [Fiset et al. \(2000\)](#). The position of the movable walls (long vertical lines), displacement objects (open boxes), open positions (a, b, c, d, e; short horizontal lines), and target object (black square) are shown for each phase of the test trial. E1 denotes the location of the experimenter, and the arrows denote the direction of displacement. On allocentric trials (ALLO), in order to find the target object the dog must follow allocentric cues (e.g. search the displacement object next to the right wall). On egocentric trials (EGO), despite the manipulations of the boxes and walls, the ball remains in the same position relative to the dog's

cues resulted in the reward. Nevertheless, the use of dead reckoning/path integration (i.e. the utilization of nondirect egocentric navigation) has been clearly demonstrated in studies where dogs have been shown to relocate a food target after the dog itself has been physically displaced while controlling for visual and olfactory cues (Cattet & Etienne, 2004; Séguinot et al., 1998). These results all point to the apparent ability of dogs to utilize spatial cues in a complex and potentially flexible way as they navigate/search for desired locations.

Fiset (2007) also conducted the first attempts to measure landmark use by dogs in searching for rewards in an open space. Dogs were trained to locate a buried ball near the center of a room. During the training trials, two separate landmarks were placed near the ball's location. On test trials, the ball was removed and the landmarks were systematically displaced. By analyzing where the dogs attempted to dig Fiset (2007) was able to measure how the dogs' search behavior was affected by the landmark manipulations. The dogs' searches shifted in the directions expected by the landmark displacements, but not to the full distance predicted (e.g. moving the landmark laterally to the left 20 cm would result in the dogs searching to the left of the initial location, but typically not the full 20 cm). Fiset (2007) concluded that the dogs were not exclusively using the landmarks to facilitate navigation, but were probably also using global environmental cues (e.g. room walls) to guide their searching.

Fiset (2009) followed up the above experiment by directly examining the effect of nearby extended surfaces (i.e. room walls) on landmark-based search behavior in dogs. In this study a ball was hidden in two locations. In the first case, the ball's location was equally distant from the back wall and a single landmark. In the second case, the ball's location was near the corner of the room so that two walls and the landmark were equidistant to the ball location. Again by moving the landmark systematically and recording the

---

initial location (e.g. position c). On control trials, the positions of all the objects do not change after manipulation and thus utilizing either egocentric or allocentric cues would result in a successful search (reprinted with permission of the American Psychological Association). (B) Illustration of L-shaped and U-shaped detours similar to those used in Fiset et al. (2007). In either scenario, the dog witnessed the hiding of the target object at one of the displacement objects from the "encoding opening" before an opaque sliding door blocked access to the displacement objects. After the door blocked the "encoding opening," an experimenter carried out the manipulations similar to those shown in (A). After the manipulations were done, the dog was then allowed to detour toward the "searching opening" in order to approach the displacement objects.

dogs' search locations, the evidence suggested that the dogs encoded the distance of the ball to both the landmark and the extended surfaces, averaging the distances from both to help determine a search position. Taken together, in order to navigate dogs appear to flexibly utilize a variety of both egocentric (i.e. direct linear cues and nondirect navigation) and allocentric (i.e. landmark and global cues) spatial cues to flexibly navigate through their environment efficiently.

#### 4.1.7.2. Search Order

From an ecological perspective, dogs are scavengers and have been seen to cache resources (MacDonald & Carr, 1995). In both of these contexts the ability to search multiple sites efficiently is advantageous. Searching efficiency is also a critical skill in a number of jobs in which humans employ dogs (e.g. search and rescue, odor detection). Yet, to date very little empirical research has explicitly investigated the search strategies and mnemonic spatial skills utilized by dogs when searching multiple locations.

Fabrigoule and Sagave (1992) investigated the ability of dogs to navigate six radially distributed food sites within an open space, and analyzed each dog's search strategy across trials. Dogs were extremely efficient in exhaustively searching the sites, making very few repeated searches or search omissions. This overall efficient performance was despite large individual differences in each dog's search-order strategy. For example, one dog quickly adopted a circular search pattern, while other dogs were more sporadic in their searching order. Search order strategies of dogs have also recently been tested using an eight-arm radial maze, and while dogs performed better than chance at remembering previously searched reward locations, dogs were found to be less efficient at locating rewards in a maze relative to searching multiple-reward locations in an open field (Craig *et al.*, 2012; Macpherson & Roberts, 2010). During navigation in the radial-arm maze, numerous repeated searches of reward locations by subject dogs were observed (particularly during the later portions of searches), suggesting the possibility that memory constraints limited the dogs' ability to remember which arms were visited previously. It is therefore possible that the difference between having six and eight potential food sites could explain these differences in performance. It is also possible that differences in experimental set up (open search area versus radial arm maze) could have impacted performance. For example, the artificial nature of the radial maze may have been disorienting.

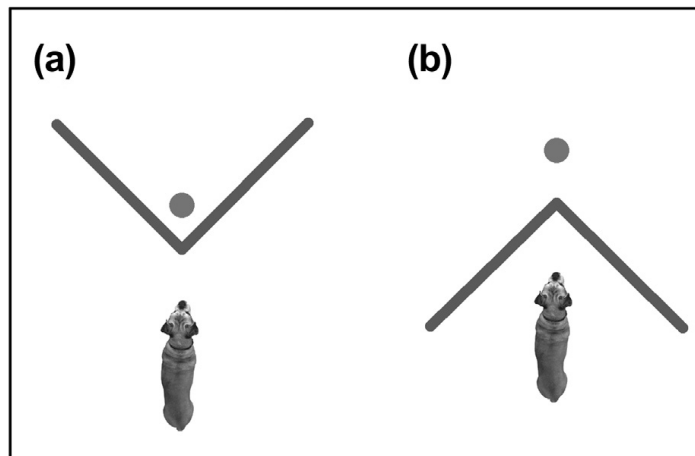
Fabrigoule and Sagave (1992) also noted stereotypies in their subject dogs' search strategies over the course of numerous repeated trials (i.e. dogs

would repeat the same search order across trials), which the authors concluded helped the dogs remember previously searched locations. The use of stereotyped search strategies may have also contributed to the improved performance over trials recorded in the initial phases of the radial arm maze studies (Craig et al., 2012; Macpherson & Roberts, 2010). Also related to learning specific search order strategies, Fabrigoule and Sagave's (1992) research gave trials in which the baiting of one location was associated with the baiting of other specific locations for that trial. These dogs were able to learn that information from one site could be used to efficiently search the remaining possible sites. In the 8-arm radial maze studies, similar attempts were made to see whether the subject dogs could use prior experience to efficiently search four baited arms without also searching the four unbaited arms, but this procedure resulted in more mixed performances (Craig et al., 2012; Macpherson & Roberts, 2010).

Finally, researchers have begun to investigate spatial cue preferences on dog search order strategies. When given multiple search sites to explore, dogs appear to randomly select which target to visit first if the targets are equally distant from the dog's starting position (Dumas & Pagé, 2006). However, Dumas and Pagé (2006) found that if some targets are closer to the dog than others, dogs rely on a least-distance rule, and if repeatedly brought back to the same starting point after searching one location, dogs will persevere toward the closer targets, repeatedly visiting previously searched (i.e. the closest) sites before searching the other sites.

#### 4.1.7.3. Detour Problem-Solving

Measuring the ability of dogs to navigate a path around a barrier has been a common strategy for evaluating spatial problem-solving skills in dogs (e.g. Thompson & Heron, 1954; Wyrwicka, 1959). Much of the research utilizing this paradigm has been aimed at understanding social learning (see Section 4.3.4.2). Nevertheless, detour problem-solving studies have also shed light on how the nature of the barrier and the required detour can affect the ways in which dogs learn to navigate. For example, when presented with a V-shaped fence detour, dogs perform worse when they start outside the V compared to inside (Pongrácz et al., 2001; Fig. 5.8). Pongrácz et al. (2001) also found evidence that experience gained from either detouring inward or outward seemed to be dissociated, as repeated experience with the inside-outside detour did not result in dogs detouring faster when placed outside of the fencing. Even repeated experience (up to 6 trials) did not result in significant improvement when dogs were asked to solve the detour by themselves.



**Figure 5.8** Illustration of the difference between the (a) inward and (b) outward barrier detours. Dog is at the initial starting position, and the gray circle represents the target object.

Researchers have also utilized detours to analyze the spatial cues associated with navigation choices and perseveration. When two potential detours are of the same length, dogs show no side bias in their initial choice (Pongrácz *et al.*, 2001; Pongrácz, Miklósi, Timár-Geng, & Csányi, 2003). However, after initial trials, previous experience can dictate the direction of later detours (Pongrácz, Miklósi, Timár-Geng, *et al.* 2003), and once a path has been established, dogs appear to have a difficult time rerouting even when the initial route is clearly no longer a possibility (Pongrácz, Miklósi, Kubinyi, Topál, & Csányi, 2003). This perseveration effect can be seen after only 2 trials, though there also appears to be significant individual differences in detour-choice flexibility (Osthaus, Marlow, & Ducat, 2010). Chapuis, Thinus-Blanc, and Poucet (1983) manipulated the transparency, angle, and length of the barrier screens and found these variables affected which direction dogs preferred to detour. When the barrier was opaque, and one side of barrier was shorter than the other, dogs showed a strong preference for taking the shorter detour. However, this was not necessarily the case when the barrier was transparent; dogs appeared to use differences in angular deviation to choose routes to reward sites instead. Further barrier-task studies with dogs should continue to provide unique insight into how animals use spatial cues to problem-solve during navigation.

*Spatial cognition synthesis and future directions:* While navigating toward desired locations and searching for hidden objects, dogs appear to develop novel spatial shortcuts based on their knowledge of previously used paths;

this behavior indicates the ability to use cognitive maps at some level. When encoding the location of an object, dogs can use spatial cues that relate the position of the object to the dog's own position as well as how the object relates to nearby landmarks and global environmental features. Dogs appear to use these sources of information flexibly based on distance, direction, and information gained on recent visits.

Reports on the search-order efficiency of dogs when exhaustively searching multiple locations are mixed. Future research could aim to better understand how the number of locations affects the susceptibility of search redundancies, examine the impact of environmental features on search order efficiency, and improve our understanding of individual differences in the search-order strategies. Future research should also aim to replicate previous results, particularly in cases where sample sizes were limited (e.g. [Fabrigoole and Sagave \(1992\)](#) had six subjects) as well as expand upon the paradigms utilized thus far. For example, in addition to the radially organized experimental designs, future research could investigate how search-order is affected by more "naturalistic" conditions (e.g. working-environment for a hunting or detector dog, home environment for a pet dog, etc.). In addition, new paradigms adopted from other taxa may provide new insights into spatial cue and memory effects on search performance (e.g. food-caching paradigms in corvids: [Clayton & Dickinson, 1999](#); Hamilton-Search task in primates: [Ha, Mandell, & Gray, 2011](#)).

Detour tasks have shown that dogs vary in their ability to solve different variations of the same detour structure, and sometimes the ability to learn a specific detour solution appears to be dissociated from other detour contexts. While early studies utilizing detour paradigms often used puppies as subjects ([Clarke, Heron, Fetherstonhaugh, Forgays, & Hebb, 1951](#); [Scott & Fuller, 1965](#); [Thompson & Heron, 1954](#), [Wyrwicka, 1959](#)), their focus was not on the development of spatial problem-solving skills. Studies that measure spatial cognition development in dogs are currently lacking, and almost any developmental study on the topic would be welcome.

#### **4.1.8. Memory**

Memory is a major topic in the study of animal cognition ([Spear, Miller, & Jagielo, 1990](#)). Dog research has mostly examined dogs' working memory (e.g. [Craig et al., 2012](#); [Fiset et al., 2003](#); [Head et al., 1995](#); [Miller et al., 2009b](#)). Other types of memory that have received some attention are episodic and long-term reference memory, though studies focused on these types of memory have been rare (e.g. [Demant, Ladewig, Balsby, &](#)

Dabelsteen, 2011; Fujita *et al.*, 2012; Gazit, Goldblatt, & Terkel, 2005b; Kaminski, Fischer, & Call, 2008).

With working memory experiments, time delays between the presentation of choice options and the initiation of the choice require the subject to maintain a mental representation of the trial scenario for the duration of the delay in order to respond accurately. Delays can be initiated during training or only on test trials, and tend to be anywhere from a couple of seconds (e.g. Ward & Smuts, 2007) to a few minutes (e.g. Fiset *et al.*, 2003). For example, Fiset *et al.* (2003) applied various time delays in a hidden object search test paradigm. In this study, there were 4 location sites, thus searching at chance levels should result in a 25% success rate. With a 10-s delay, the average success rate was near 80%. With a 240-s delay the success rate was lower, but still near 50%. Kowalska (1997) tested the ability of dogs to complete a match-to-sample two-choice task using auditory cues; performance dropped from 90.3% with a 1.5 s delay to 63.4% after a 90 s delay. The difficulty of the tasks appears to also have an effect on working memory; as more difficult tasks are used, increased time delays have greater effects on working memory (e.g. Miller *et al.*, 2009b).

Memory-based dog studies have been particularly influential in developing a canine model of cognitive decline; Canine Cognitive Dysfunction is thought to be an analog of human Alzheimer's disease (Adams, Chan, Callahan, & Milgram, 2000). Researchers have found that the use of varying time delays has been successful in differentiating young and aged dogs in terms of cognitive functioning (Head *et al.*, 1995). Delays in combination with utilizing tasks of varying difficulty have also been used to help differentiate between severely cognitively impaired dogs, who often fail to reach criterion during training phases, from slightly impaired and unimpaired aged dogs (Adams, Chan, Callahan, Siwak, *et al.*, 2000). With age, dogs tend to have a more difficult time continuing to perform at criterion level in memory tests as time delays increase (Tapp, Siwak, Estrada, Holowachuk, & Milgram, 2003).

Establishing the use of episodic memory requires the animal demonstrating knowledge about what, where, and when an event occurred. Foraging tasks have been used to demonstrate episodic memory in birds such as scrub jays (*Aphelocoma californica*; Clayton & Dickinson, 1999). Using two different types of food rewards, including one that was preferred but time-sensitive (e.g. wax worms versus peanuts), scrub jays have been shown to selectively forage for the two rewards based on the length of the time interval since their last visit to that site. Thus, the scrub jays appeared



to know what they were searching for, where it was located, and when it was initially cached.

Recently, researchers have begun to examine whether dogs demonstrate episodic memory; the focus thus far has been on the questions of “what” and “where” an event occurred. Kaminski et al. (2008) tested two dogs (including Rico, discussed in Section 4.1.4.1) by asking them to retrieve multiple objects from two separate rooms after being given a chance to view each object's location initially. Both of the dogs displayed the ability to remember “what”, but only Rico's search pattern indicated potential knowledge of the exact location of each object (the “where”), or that he at least chose to use that capability. The other dog, Betsy, chose to follow a set search pattern regardless of the object's location, always entering the same room first and then only searching the second room if the object was not found in the first.

Studies have also begun to evaluate episodic memory in dogs in a foraging context (Fujita et al., 2012). This research was specifically aimed at measuring episodic memory by investigating whether a specific previous event could influence the behavior of dogs later on despite the dog being given no explicit cues that it needed to remember anything about the first event. In the first experiment of their study, Fujita et al. (2012) instructed owners to walk their dogs to four baited food sites; dogs were allowed to eat from two of them. The dogs were then taken for a 10-min walk and then “unexpectedly” returned to the lab and allowed to freely search (the original containers had been replaced with empty ones to control for potential odor cues). Eleven out of 12 dogs first went to one of the containers where the dogs had not been allowed to eat the treat, suggesting that the dogs were remembering without any training or prompting “where” items were from first pass through. Experiment 2 looked to see whether dogs encoded both “where” and “what” was located in each container. In this experiment, Fujita et al. (2012) instructed owners to walk new subject dogs to a series of four food dishes; two contained food and the dogs were allowed to eat from one. The third container had an inedible object, and the fourth was empty. After a 10-min walk, dogs were returned to the experimental room and allowed to search freely. Nineteen out of 39 dogs went to the container that they had not been able to eat from on the first pass, and 11 of the remaining 20 dogs visited the container where they had already eaten food. Together, 30 out of 39 dogs first visited one of the containers that had originally had food. From these results Fujita et al. (2012) suggested that dogs are able to use episodic memory to improve their chances of successfully

collecting uneaten food, concluding that dogs remembered the “what” and the “where” of previous foraging locations.

What is completely unknown is whether dogs conceptualize the “when” of events in their memory. Despite being a topic consistently found throughout the animal cognition literature (e.g. Shettleworth, 2010; Wasserman & Zentall, 2006), research on time representation and “mental time travel” (Suddendorf & Busby, 2003) in dogs is sparse. In one study, dogs were left alone for varying amounts of time and then reunited with their owners (Rehn & Keeling, 2011). Dogs were observed to behave differently (e.g. they were more active, attentive to their owners, and sought attention from them) after longer separation durations (2 and 4 h) relative to a shorter one (0.5 h). Another study indicates that different lengths of time delays have an effect on dogs’ willingness to participate in an exchange task (e.g. choosing to not eat an immediate small reward in order to wait for a delayed larger reward); dogs are less willing to wait to make an exchange for a much larger reward if the required time delay is too long. (Leonardi *et al.*, 2012). More studies are clearly needed but these findings certainly seem to suggest that time durations may be incorporated as a variable into canine decision-making. Clearly, research on episodic memory and particularly “mental time travel” in dogs is a fruitful area of future research.

Studies of long-term reference memory in working-dogs have been used to understand the performance of these dogs in different environments (Gazit *et al.*, 2005b). Using well-trained explosive detection dogs, Gazit *et al.* (2005b) investigated the effect of extinction training on search performance (i.e. continually being worked on a path that has no reward markers, in this case the odor of an explosive). Dogs were taken on daily searches of one of two paths. On path A there were always explosives hidden, while on path B there were never explosives hidden. Gazit *et al.* (2005b) observed that even after a single search of path B dogs exhibited behaviors (e.g. movement speed) that indicated decreased motivation on subsequent searches. More importantly, reduced motivation and behaviors indicative of high-detection performance continued to be low on path B even when explosives were ultimately hidden on it. Thus, dogs appeared to remember aspects of the search paths over a number of days, and these memories continued to impact subsequent behavior and performance even when conditions had changed. Further study on long-term memory is needed, especially since many working-dogs (e.g. detection dogs) work in the same or similar environments with stochastic, potentially infrequent “rewards” (i.e. finding actual explosives).

*Memory synthesis and future directions:* The majority of memory research in dogs has focused on evaluating working memory. By administering delays between an encoding phase and when the dog is allowed to either search for a hidden object or make a stimulus choice, researchers have shown that dogs can perform above chance levels with delays up to several minutes. In general, however, working memory performance on tasks with delays declines with age, and overall dogs do worse on longer delays when the search task is more difficult.

Other types of memory such as episodic and long-term memory have received less attention, but provide a basis to start research on the topic. In addition, future research may find existing test paradigms from other taxa (e.g. birds: Zentall, Singer, & Stagner, 2008) to be useful in studying episodic memory in dogs. Research related to the time perception of events, a major study in other taxa, is specifically lacking. Some referential long-term memory effects have been demonstrated in dogs, but more studies are needed before any generalizations can be made. Understanding how environmental variation and the temporal dynamics of finding “rewards” interact to impact dog memory and subsequent behavior should be fruitful areas of research from fundamental and applied standpoints.

## **4.2. Generalizations and Recommendations for Future Studies on NonSocial Cognition**

1. *There is a strong need for further replication of results.* While the breadth of nonsocial cognition studies in dogs is broad, in many areas very few studies exist. In addition, due to small sample sizes or the use of a limited number of breeds, it is not yet clear how generalizable many nonsocial cognition results are across different dog populations. Note that most nonsocial cognition dog studies have had sample sizes that meet their study aims, and authors tend to make appropriate inferences in general. Still, random sampling and replication are two hallmarks of empirical science, and we recommend, where possible, that efforts are made by authors to choose study designs and sample sizes that will allow for the greatest generalization possible. This goal is especially important where a nonsocial cognition topic directly informs applied work.
2. *Thus far the majority of nonsocial dog cognition research has utilized visual-based test paradigms.* Canines have highly developed olfactory perception (Quignon, Rimbault, Robin, & Galibert, 2012), which has made them well suited for numerous working roles that depend on olfaction (Harper, Almirall, & Furton, 2005). By adapting current discrimination

and object learning paradigms to include nonvisual cues, future research could further investigate how different sensory modalities interact, facilitate learning, affect memory, and contribute to mental representations of objects. For example, categorization-discrimination paradigms could be adapted to investigate whether dogs naturally categorize groups of scents that humans assume go together (e.g. similar chemical odor signatures; Furton & Myers, 2001) and measure how olfactory learning may be affected depending on the ways dogs categorize odors.

3. *Research is needed on development.* For the majority of nonsocial cognition topics, very little is known about patterns of development (for an exception see Gagnon & Doré, 1994). Cross-sectional and longitudinal research tracking individual puppies may help improve understanding of cognitive maturity and how early experiences, along with current conditions, alter or facilitate nonsocial cognitive processes in later life. For example, research could focus on the impact that object-permanence development has on the development of spatial cognition and search order strategies (for examples in rodents, see: Green & Stanton, 1989; Reger, Hovda, & Giza, 2009; Rossier & Schenk, 2003; Rudy, Stadler-Morris, & Albert, 1987).
4. *Research is needed to explore dogs' understanding of time.* The ability to utilize mental time travel (awareness of one's past or future) has traditionally been thought to be a uniquely human trait, but has become a regular topic in the animal cognition literature (Cheke & Clayton, 2010; Suddendorf & Corballis, 2010). Additionally, a significant amount of research on comparative cognition has aimed to understand the mechanisms that result in animals incorporating concepts of time into their behavior choices (Church, 2006; Crystal, 2006). Yet, almost no research has been conducted looking at time-related cognition in dogs. Studies investigating whether other animals remember "when" events occur (e.g. Clayton & Dickinson, 1999) or whether other animals understand "timing" (e.g. Fetterman, 1995; Kirkpatrick & Church, 2003) could be adapted and applied to dogs in future studies.
5. *Research is needed on individual differences.* A number of nonsocial cognition studies have made posthoc observations concerning individual differences. Future dog cognition research could begin to investigate short- and long-term consistencies of these putative differences, as well as determine how to reliably measure different nonsocial cognitive parameters in individuals, a subject currently being pursued in the dog personality studies (Jones & Gosling, 2005; Wilsson & Sinn, 2012).

Researchers interested in comparative, ecological, and applied outcomes of nonsocial cognition processes may study how individual differences, along with other biological, social, and environmental factors, result in later adult behavior (for examples from dog personality studies, see: Maejima et al., 2007; Sinn, Gosling, & Hilliard, 2010).

Exciting future work might also examine potential nonsocial cognitive “tradeoffs” and individual strategy specializations. For example, as well as natural variation in individual dog’s cognitive abilities in a given nonsocial cognitive domain, some individuals also appear to utilize particular cognitive strategies over others when approaching problems (Aust et al., 2008; Nippak et al., 2003). Cognitive strategy specializations might occur if individuals choose one mental approach over another when attempting to solve the same problem, and variable environments facilitate and encourage different specializations (e.g. Stamps & Groothuis, 2010). Research on identifying evolutionary, ecological, biological, and social factors that favor one cognitive specialization over others would be fruitful, and would contribute to the growing interest in animal specializations in ecology and evolution in general (Dall et al., 2012; Wolf & Weissing, 2012). It is possible, if not likely, that individual dogs may also be cognitively constrained, either because of limits to cognitive load processing or if performance in one cognitive context is negatively correlated with performance in another. Individuals in this case could face cognitive tradeoffs across several nonsocial cognitive domains, helping explain individual differences in any one domain, a topic of high fundamental and applied interest. Repeat measurements of the same individuals on multiple cognitive tasks through time (using appropriate learning controls) should be a useful starting point for further work in these areas (see Section 5).

### 4.3. Social Cognition

Studies demonstrating that dogs are not only adept at utilizing human cues, but can also sometimes outperform humans’ closest evolutionary relatives in that regard (Hare & Tomasello, 1999; Miklósi, Polgárdi, Topál, & Csányi, 1998) have garnered a great deal of academic and popular attention over the last decade (Morell, 2009). The majority of social cognition studies in dogs can be broadly categorized into four subcategories: (1) responses to human cues, (2) perspective taking, (3) dog-to-human communication, and (4) social learning (Table 5.1; Cooper et al., 2003; Kubinyi et al., 2009; Udell, Dorey, & Wynne, 2010b; Udell & Wynne, 2008). Responses to human cues and dog-to-human communication studies have focused on the ability of

humans and dogs to communicate with one another, and the factors that affect communication effectiveness. Research on perspective taking has investigated whether dogs are sensitive to the perspective of others (humans and/or dogs), and evaluates evidence that dogs behave differentially dependent on the perspective of others (e.g. Topál, Erdőhegyi, Mányik, & Miklósi, 2006). Social learning experiments focus on the role demonstrators and social interactions have on the learning and expression of behavior. Several excellent reviews have summarized findings in each of these subcategories of social cognition (Table 5.1; see also Reid, 2009 [response to human cues], Cooper *et al.*, 2003 [perspective taking], Howell & Bennett, 2011b [dog-to-human communication], Kubinyi *et al.*, 2009 [social learning]). Here we summarize the main findings of all four subcategories of social cognition, and again highlight potential areas that might benefit from further research.

Before beginning, it is worth noting that research on canine social cognition has generated considerable debate regarding if, why, and how dogs outperform their own and humans' closest evolutionary relatives on social cognition tasks (e.g. Hare, 2007; Udell *et al.*, 2010b). The debates about canine social cognition, and more specifically canine interspecies communication center on two main issues (Elgier, Jakovcevic, Barrera, Mustaca, & Bentosela, *et al.*, 2009; Miklósi & Szabó, 2012): (1) origins of current social cognition skills, and (2) behavioral mechanisms.

The first debate on the origins of social cognition skills in dogs centers on the relative influence of early life development versus evolutionary domestication processes. Some researchers emphasize the relative influence of evolution by artificial selection (i.e. current traits arose because certain combinations of gene frequencies in dog populations were favored and maintained during domestication: Hare, Brown, Williamson, & Tomasello, 2002; Hare & Tomasello, 2005; Riedel, Schumann, Kaminski, Call, & Tomasello, 2008). Other researchers emphasize that early developmental experiences largely explain social cognition skills later in life (e.g. Udell & Wynne, 2008; Wynne, Udell, & Lord, 2008). Reid (2009) nicely reviews the major hypotheses involved in this debate, and concludes by acknowledging the reality that dogs' past evolutionary history, lifetime developmental experiences, and current conditions all are essential components of any "origin" of dogs' social cognitive abilities. Recently, other hypotheses arguing for similar phylogenetic/ontogenetic interactions on dogs' social abilities have been put forward (see Gácsi, Győri, *et al.*, 2009; Miklósi & Szabó, 2012; Miklósi & Topál, 2011; Udell *et al.*, 2010b), but authors differ in their emphasis on the relative importance of the phylogenetic and ontogenetic components.

The second major debate in canine social cognition studies focuses on the putative cognitive mechanisms that underpin social cognitive abilities observed in dogs (Elgier et al., 2009). Some researchers favor less complex mechanistic explanations, pointing to evidence where social abilities can be explained by associative learning experiences that occur throughout a dog's life (e.g. Barrera, Mustaca, & Bentosela, 2011; Bentosela, Barrera, Jakovcevic, Elgier, & Mustaca, 2008; Elgier, Jakovcevic, Mustaca, & Bentosela, 2009b, 2012). Other researchers argue that social cognitive abilities in dogs are evidence of highly complex cognitive explanations, pointing to research that indicates that dogs perceive human cues as a referential communicative signals and are sensitive to others having visual perspectives different from themselves (e.g. Bräuer, Call, & Tomasello, 2004; Kaminski, Bräuer, Call, & Tomasello, 2009; Kaminski, Pitsch, & Tomasello, 2012; Kaminski, Schulz, & Tomasello, 2012; Miklósi et al., 1998; Soproni, Miklósi, Topál, & Csányi, 2002). A key concept relevant to this debate is the “theory of mind”, in which an animal imputes a mental state to itself and others, a complex cognitive explanation of behavior (Premack & Woodruff, 1978). However, the use of human-level theory of mind as a standard for dogs has recently been questioned in the canine cognitive literature (see *Learning and Behavior*, Vol. 39; Miklósi & Szabó, 2012).

Such debates have been crucial for advancing the field of canine cognition, and studies that continue to address the origins of social skill development and the behavioral mechanisms behind them will no doubt also continue to contribute to our knowledge of comparative cognitive processes across taxa. The goal of this review is not to argue in favor of one hypothesis over the other; instead, the brief synopsis was provided to give the reader some context to the general results within each subcategory of social cognition described below.

#### **4.3.1. Response to Human Cues**

Through the use of object–choice discrimination paradigms, the ability of dogs to utilize a variety of directional cues given by humans has been evaluated extensively. In the most common two–choice paradigm, an experimenter is typically positioned between two potential food sites, one of which is loaded with a reward. The experimenter then provides a cue toward the location of the reward, and the subject dog is allowed to make a choice between the two options. The specific cues used across studies can vary widely, but typically include arm extensions, head turns, and/or eye gazes. Cues can be momentary (presented and taken away before the dog

is allowed to make a choice) or can be present during the dog's choice (see Miklósi & Soproni, 2006 for a review). Dogs have consistently been found to perform best when the cue is a basic arm extension where the index finger is close (within 30 cm) to the target site and remains there while the dog makes a choice (Hare *et al.*, 2002). Performance can vary widely with the use of different human cues, and there is some evidence of population differences in utilizing human cues (see below), but dogs have been found to use many types of human cues successfully, including very subtle cues such as eye gaze only (Agnetta, Hare, & Tomasello, 2000; Ittyerah & Gaunet, 2009). Dogs often show immediate recognition of the communicative nature of many of these cues, and in cases where dogs do not immediately follow a type of human cue, they can quickly learn (Miklósi *et al.*, 1998; Soproni, Miklósi, Topál, & Csányi, 2001, 2002; Udell, Giglio, *et al.*, 2008; Udell, Dorey & Wynne, 2010a). The addition of human ostensive cues (*i.e.* cues meant to signal the communicative intention of the behavior), particularly the human making direct eye contact with the subject, will affect whether dogs make use of a communicative signal (Kaminski, Schulz, & Tomasello, 2012; Téglás *et al.*, 2012).

Dogs appear to find social cues to be more salient or effective than non-social cues in terms of signaling the location of a reward in an object choice context. When human social cues (*e.g.* pointing) are compared directly with nonsocial cues (*e.g.* a visual marker cue where the dog does not see the marker's placement), task performance using social cues is consistently found to be superior (Agnetta *et al.*, 2000; Udell, Giglio, *et al.*, 2008). The relative saliency of social cues holds even when nonsocial cues provide direct evidence of the rewards location, such as when the experimenter places two boards on the ground, with food under one of them so that the reward location is visible to the dog (Bräuer, Kaminski, Riedel, Call, & Tomasello, 2006). It should also be pointed out that research suggests that the ability to use human cues by dogs is limited to cooperative contexts (Wobber & Hare, 2009), as dogs show no evidence of inferring the location of a reward using human social cues in a competitive context (Pettersson, Kaminski, Herrmann, & Tomasello, 2011). This pattern contrasts with the trend seen in apes (Herrmann & Tomasello, 2006).

There has been some research on the development of responses to human pointing in dogs. Hare *et al.* (2002) found puppies 9–24 weeks old successfully used “gaze + pointing” and even “gaze alone” at better than chance levels, and found no age effects between puppies that were grouped based on age or evidence of learning across the multiple trials. Riedel *et al.*



(2008) reported similar results using puppies as young as 6 weeks. Both of these aforementioned studies used basic pointing cues in which the experimenter's hand remained extended toward the target while the puppy made its choice. Gácsi, Kara, et al. (2009) used a more challenging distal momentary gesture (i.e. arm is extended toward target, extended finger is between 60 and 80 cm away from target, and stays there for only 1 s before experimenter returns arm to a neutral position), and found puppies as young as 2 months old performed significantly better than chance. Again, no learning or age effects were found.

These findings would seem to be a convincing evidence that dogs are capable of utilizing human cues at an early age but some have challenged these findings. In particular, the lack of age and learning effects reported in Riedel et al.'s (2008) study have been questioned, largely on statistical grounds, with Wynne et al. (2008) arguing that Riedel et al.'s (2008) data in fact provides evidence of both age-related performance differences and learning over trials (see Hare et al., 2010; Udell & Wynne, 2010 for further debate). More recently, Dorey, Udell, and Wynne (2010) raised methodological issues with all three previous studies, and while their own study found no evidence of learning across trials, they found a significant improvement in performance while comparing puppies from 9 to 24 weeks old. Dorey et al. (2010) reported that the youngest puppy in their study to perform above chance levels (8 out of 10 correct) was 18 weeks old. In this developmental research, there is still little agreement on how to address such methodological issues as calibrating the difficulty of the pointing task and implementing proper experimental controls. Consensus among researchers is needed in terms of how to best design experiments and statistical methods before definitive conclusions can be made about the maturation of skills related to responding to human cues.

Studies comparing the ability of different groups of dogs to follow human cues have focused on the role of both life experiences (e.g. training effects, early socialization) and dog-breeding effects. For example, McKinley and Sambrook (2000) compared the performance of working-gun dogs versus pet gun dogs and pet nongun dogs on human pointing cue response trials. Gun dogs that were specially trained in hunting tasks that involved responding to cues from a distance utilized a pointing cue significantly more than dogs from the other two groups, which did not differ from one another in their use of pointing cues. However, research comparing agility-trained dogs (Gácsi, Kara, et al., 2009) and guide dogs (Ittyerah & Gaunet, 2009) to pet dogs did not find any group differences in social responses to

pointing cues, indicating that the type of training, and not just training *per se*, may be important in the development of this communication skill.

Research has also begun to compare shelter dogs with pet dogs as a strategy for measuring the possible effects of early socialization with humans on how well dogs respond to human cues. The assumption of these studies is that shelter dogs have had less exposure than pets to humans outside of basic care, and therefore, pet dogs should have higher performance in response to human pointing trials. Udell, Dorey, and Wynne (2008) found that pet and shelter dogs did have differences in responses, with shelter dogs initially being less successful than pet dogs at following a distal momentary-pointing gesture. Hare *et al.* (2010) questioned these findings on both statistical and methodological grounds, and conducted a separate study in which shelter dogs were shown to follow human cues when using different procedural methods and human pointing cues (*i.e.* pointing cues were closer to target locations than those used in Udell, Dorey, *et al.*, 2008). In response, Udell *et al.* (2010a) replicated Hare *et al.*'s (2010) findings in terms of using closer pointing gestures, but again replicated their own earlier findings that shelter dogs initially were unsuccessful at utilizing the more difficult, distal momentary gestures. Udell *et al.* (2010a) also reported, however, that their shelter-dog subjects learned to respond correctly to the more difficult cues with repeated trials. Again, consensus amongst researchers in terms of standardized assays and appropriate statistics is needed before any conclusions can be made regarding the role of early experience on dogs' abilities to respond to human cues.

In terms of potential breed effects, breeds that have been historically bred for working purposes respond to human pointing cues significantly more than breeds that have been bred for companionship, though all breeds perform better than chance (Wobber *et al.*, 2009). Differences have also been found between breeds that were originally bred for cooperative work (*e.g.* herding) versus those that were bred for independent work (*e.g.* guarding) with cooperative breeds outperforming independent breeds on pointing tasks (Gácsi, McGreevy, *et al.*, 2009). Morphological differences may also play a role in response performance as brachycephalic (short-muzzle) dogs respond to human pointing better than dolichocephalic (long-muzzle) dogs, presumably because the shape of their head results in differences in their visual field (Gácsi, McGreevy, *et al.*, 2009). Larger dogs also tend to perform better than smaller dogs (Helton & Helton, 2010), further suggesting that breed differences in response to human pointing cues can be due to differences in morphology and resulting visual physiology. However,

a meta-analysis on breed differences based on American Kennel Club Groupings as well as recent genetic-based clusters (see Parker & Ostrander, 2005), found no breed differences in dog responses to human cues, but it was noted that there was underrepresentation of many breeds and an inability to gain access to other researcher's data, which may have contributed to the negative results (Dorey, Udell, & Wynne, 2009).

One intriguing aspect of human-cue object choice research is the wide variation in individual performances observed between dogs. For example, Gácsi, Kara, et al. (2009), found that over half of the dogs in their human-cue object choice study did not perform significantly above chance levels in response to a momentary distal-pointing gesture. Of the 180 dogs originally tested, 36 were randomly selected and retested (15 had performed above chance levels on their first test), but the time between the two tests varied from one week to a few months across dogs. During the retest, only 7 dogs saw their performances change, with some now performing above chance levels after failing to do so on the first test, and others seeing their performances dip under chance levels after previously performing above chance. To our knowledge, Gácsi, Kara, et al. (2009) gave the first demonstration of consistency of individual differences in responses to human pointing cues over time. Unfortunately, their results were confounded with different test intervals given to different dogs, but these results again point to the need to pay greater attention to individual differences among dogs.

Interestingly, there are a number of studies demonstrating that the following of human cues can at times result in apparently maladaptive choices by dogs, at least in an experimental context (e.g. Erdőhegyi, Topál, Zsófia, & Miklósi, 2007; Kupán, Miklósi, György, & Topál, 2011; Topál, Gergely, et al., 2009). For example, despite consistently choosing the larger of two piles of food when selecting alone, dogs will begin to select the smaller pile of food if their owner shows a preference for it (Prato-Previde et al., 2008). Furthermore, even when dogs are allowed to directly smell where food is hidden before making a choice, dogs show a significant preference for following the human cues even if this results in no reward (Szetei, Miklósi, Topál, & Csányi, 2003). This bias occurs with both owners and strangers as the signalers (Marshall-Pescini, Prato-Previde, & Valsecchi, 2011), and has also been observed when the signaler is a dog (Cooper et al., 2003). Dogs are eventually able to learn to stop responding to the deceptive cues (Elgier, Jakovcevic, Mustaca, et al., 2009; Petter, Musolino, Roberts, & Cole, 2009), but again there is a strong initial bias that can be difficult for dogs to inhibit. It is important to recognize, however, that in the broader sense, such a bias

is highly beneficial because in realistic ecological contexts following human cues is likely to result in a reward.

The predisposition of dogs to move toward apparent human preferences, along with the dog's ability to use subtle cues, means trainers and dog handlers need to be particularly careful not to provide inadvertent cues that may affect the decision-making behavior of their dogs. The potential risk of such cuing was demonstrated by Lit, Schweitzer, and Oberbauer (2011) who asked handler/dog odor-detection teams to search multiple rooms for target scents. The handlers' beliefs were influenced by the experimenters' verbal instructions that included telling the handler that a visual marker denoted the location of the target objects. In addition, the dogs were potentially influenced by the placement of decoy scents that the experimenters thought might induce signaling behaviors from the dog (but that dogs were not previously trained on). Despite no actual target scents being planted in any of the rooms, 225 alerts were issued over 144 different searches by 18 handler/dog teams. Lit *et al.* (2011) found that alerts were more likely to be made on searches where there was a visual marker (human influence) versus when there was only a decoy scent (dog influence) or neither. Clearly, subtle (and perhaps unconscious) human cues can sometimes have a significant impact on the effectiveness of odor-detection human/dog teams, and further work on salient human cues and signals that dogs use to make choices should be especially useful.

Finally, recent research on how dogs respond to human cues has begun to expand past the two-choice paradigm where one experimenter offers a basic directional gesture, and instead has begun to evaluate how dogs perform in more complex scenarios. For example, Lakatos, Gácsi, Topál, and Miklósi (2012) observed how dogs responded to human cuing when there was a total of four potential food sites, with two on each side of the experimenter. The results from this study suggest that dogs follow the side of the gesture, and do not necessarily interpret the signal as referencing a specific object when there are multiple objects in that direction (also see Grassmann, Kaminski, & Tomasello, 2012). Lakatos *et al.* (2012) also reported potential evidence of dogs being able to follow indirect pointing signals, where the dog's owner points to one of two other people, who then directly points to one of two food sites. Kundery *et al.* (2012) used a paradigm whereby two people pointed at an empty bucket while only one person pointed at the reward bucket and found that even though the buckets were transparent so that the dog could see the reward location, dogs tended to choose the bucket with two people pointing at it. However, it appears that the number

of hands used by humans to point also matters, because when the single person used both hands to point and the two people only used one each, the dogs tended to choose the correct reward location (Kundey et al., 2012). Finally, Buttelmann and Tomasello (2012) recently utilized human emotional expressions as cues for two potential food sites, and report evidence of dogs discriminating between expressions of “happy” and “disgust” to dictate search behavior. There is a rich body of research on the abilities of dogs to respond to human cues. Further attempts to incorporate more complex and realistic scenarios should continue to provide important additions to the literature.

*Response to human-cues synthesis and future directions:* The ability of dogs to respond to human cues in a cooperative search context is well studied. Dogs have been shown to reliably follow a set of basic human cues (e.g. distal/proximate pointing, head turns, eye glances), as well as being adept at flexibly generalizing this behavior to relatively novel human movements (e.g. “cross-pointing”, leg pointing; Soproni et al., 2002; Udell et al., 2008a). Research also shows that a dog’s future use of human cues is highly malleable depending on reinforcement history (Elgier, Jakovcevic, Mustaca, et al., 2009). Recent work has begun to study how more subtle (and perhaps unintentional) human cues impact communication interactions between dogs and human. Future work on identifying and reliably measuring relevant context-specific human signals and cues should yield significant insights (e.g. Kis et al., 2012; Kupán et al., 2011; Marshall-Pescini, Passalacqua, MilettoPetrazzini, Valsecchi, & Prato-Previde, 2012).

Research related to the effects of ontogeny on the ability of dogs to utilize human communicative signals (both through puppy studies and comparisons between dog populations) has been the catalyst to much debate but very few studies have actually been conducted, and fundamental differences in experimental methodologies make it difficult to generalize from the findings. More research on standard protocols to address development of communicative skills would be welcome.

Studies examining responses to human cues have mainly used a two-object choice paradigm. Future research should continue the goals of recent studies by developing more complex and challenging test environments. It is also important to expand future research into applied contexts. For example, research could evaluate how the social cognitive test paradigms currently used in fundamental research could promote a particular type of desired human–dog bond in various applied fields (working-dog programs, puppy socialization, adoption retention, etc.; Howell & Bennett,

2011b). Additionally, future research could pursue questions regarding the reliable measurement and impact of individual differences in dogs in their abilities and desires to respond to human cues, including studies determining whether some dogs are more predictable than others with regard to their use of human cues and trainability (Fratkin, Sinn, Patall, & Gosling, 2013). Research on individual differences could provide novel methods for selecting working-dogs, particularly for jobs where responding to human signaling is a key job requirement (e.g. most working-dog types).

#### **4.3.2. Perspective Taking**

Research in dogs has also studied their ability to attend to changes in human attention states and to take into account the perspective of others to adjust their own behavior. In an early study on the topic, Hare, Call, and Tomasello (1998) demonstrated that dogs that retrieved an object preferred to drop the object in front of the human, and would even maneuver around to do so if the human's back was to them, providing observational evidence of dogs' knowledge of a human's visual field. Call, Bräuer, Kaminski, and Tomasello (2003) coded the behavior of dogs that were verbally forbidden to eat a sample of food by the experimenter. The experimenter's attention toward the dog varied across treatment conditions, from eyes open and focused on the dog, to eyes open and not focused on the dog, to eyes closed, and finally to the experimenter having his/her back turned. Call *et al.* (2003) found that the dogs ate significantly less food after being verbally forbidden to do so when the experimenter's eyes were open and focused on the dog than in the other conditions, again suggesting that dogs perceive signals known to reflect human attention-states. Similar results were found when it was the owner verbally discouraging the dog, and the dog was put in a down-stay with the food being used as a distraction (Schwab & Huber, 2006).

Human attention-state changes have also been found to alter dog command responses and begging behaviors (Gácsi, Miklósi, Varga, Topál, & Csányi, 2004; Udell, Dorey, & Wynne, 2011; Virányi, Topál, Gácsi, Miklósi, & Csányi, 2004). Virányi *et al.* (2004) found dogs responded more readily to commands when the human interacting with them was directly facing them compared to when the human was oriented toward another human or when the human was not present. Intermediate levels of response were seen when the human was looking into open space. Researchers have also utilized paradigms whereby dogs are given the choice to beg for a reward from two different humans. Virányi *et al.* (2004) found that when given a choice between begging from a human who was either facing toward or

away from them, dogs showed a preference for approaching the human who was facing them, providing some evidence that dogs are also able to connect human attention to food sharing potential. Gácsi et al. (2004) found further support for human attention-state differences affecting dog responses by altering both head orientation and eye visibility of the demonstrator-humans; in general, dogs prefer to beg for food from a “seeing” human.

Further recent studies have used experiments designed to distinguish whether dogs are truly paying attention to human attentional states, or whether earlier results could be explained through more parsimonious discrimination learning processes, such as humans’ eyes acting as a discriminatory cue. By using barriers and manipulating their orientation, size, and shape, Bräuer et al. (2004) found that dogs approached a forbidden treat more when the barrier effectively blocked the experimenter’s view of the treat even though the experimenter’s focus was constant across all conditions and the experimenter could witness the dog’s initial movements. Kaminski, Bräuer, et al. (2009) also collected strong evidence that dogs are not simply discriminating on the basis of the human’s eyes being opened or closed by utilizing a cooperative task in which the experimenter sat across the room from the dog and asked the dog to retrieve a ball. There were two balls to choose from, and during experimental trials there was a small barrier between the experimenter and each ball. One barrier was opaque while the other was transparent, so that the experimenter could see only one of the balls, but the dog could see both. When the experimenter asked for the dog to retrieve the ball, the dogs showed a preference for approaching the ball in front of the transparent barrier, suggesting that the dogs were aware that human could only see that ball and therefore it must be the one that is being requested. Even more recently, Kaminski, Pitsch, et al. (2012) manipulated the lighting within the experimental space, and found that dogs took forbidden food significantly more when the food was in the dark than when it was illuminated, independent of whether the human’s face was illuminated or not. Additional evidence against dogs using only discriminatory cues can be found with some studies that seem to indicate that dogs also appear capable of taking into account what others can or cannot hear (Bräuer, Bös, Call, & Tomasello, 2012; Bräuer, Keckeisen, Pitsch, Kaminski, & Call, 2012; Kunder, De Los Reyes, Taglang, Allen, et al., 2010). While these results do not necessarily confirm human perspective taking by dogs, they are important first steps toward showing that dogs probably are not using a single discriminatory cue (such as presence or absence of eyes) to guide their behavior with humans.

In an attempt to measure the role of ontogeny on perspective taking behavior in dogs, Udell *et al.* (2011) recently utilized a begging paradigm using both pet and shelter dogs. Both groups of dogs preferred to beg from a human that was facing them versus one that was not. However, these results did not generalize when different visual elements were used to partially or fully block the visual attention of one of the humans. For example, when one of the humans was reading a book, pet dogs preferred to beg from the nondistracted human, but shelter dogs did not show this distinction. No groups of dogs showed a strong solicitation preference either way when one of the humans had a camera in front of that person's face. When one human had a bucket over that person's head only pet dogs tested indoors, and not the pet dogs tested outside, showed a significant preference for the "seeing" human. These results suggest that the ability of dogs to discriminate between human visual-attention cues may be context-specific and not easily generalizable. This study has sparked some interesting debate over both the interpretation of perspective taking results as well as the usefulness of these methodologies in answering questions regarding whether dogs possess complex cognitive processes such as a theory of mind (see *Learning and Behavior*, Vol. 39; Miklósi & Szabó, 2012).

*Perspective-taking synthesis and future directions:* Dogs have been observed to differentiate their actions based on human behavioral cues associated with attention. There is evidence that dogs are utilizing more than just the visibility of a human's eyes as a discriminatory stimulus; however, there is little agreement about whether current evidence is sufficiently strong to conclude that dogs take human perspectives into account when making decisions. Future work using visual cues as well as auditory and tactile ones should continue to yield useful insights into dogs' perspective-taking abilities. It is possible that dogs may use different sensory modalities depending on current conditions and environmental contexts. Additionally, there is a need for research examining the age at which evidence of attentional sensitivity first appears and for further studies comparing subgroups of dogs. Future work could also focus on developing novel test paradigms that more conclusively determine which perspective taking attributes dogs possess (Horowitz, 2011).

### **4.3.3. Dog-to-Human Communication**

Dogs do not just simply respond to human behavior. They have also learned to produce communication signals toward humans in order to carry out their own behavioral goals (Miklósi *et al.*, 2003). Most research investigating



dog-to-human communication has focused on how dogs use their gaze to communicate. For example, when placed into situations where desired objects are inaccessible (e.g. toys), dogs may use a combination of barking and alternating gazes between the human and the desired item (Miklósi et al., 2000). Dogs have also been shown to use the position of their bodies to locally enhance the location of a desired object by standing in close proximity of that object while signaling to the human (Gaunet & Deputte, 2011). Thus, dogs demonstrate not only attention-seeking behavior, but also “showing” behavior indicating the location of the desired objects. However, this type of communication seems to be limited to situations in which the hidden object is desired by the dog. Kaminski, Neumann, Bräuer, Call, and Tomasello (2011) showed that dogs would show communicative behavior to request access to a toy they themselves desired, but found no evidence of dogs informing their owners of the location of an object the owner desired though the dogs had witnessed its hiding.

Dog-to-human communication research has also attempted to investigate whether dogs are able to incorporate the knowledge states of others into their own decision-making processes (see Topál, Erdőhegyi, et al., 2006; Virányi, Topál, Gácsi, Miklósi, & Csányi, 2006). Two studies used a modified nonverbal knowledge attribution paradigm originally used with nonhuman primates (Topál, Erdőhegyi, et al., 2006; Virányi et al., 2006). The “Ignorant-Helper” paradigm requires the dog to communicate with a human helper in order to obtain a reward that is inaccessible to the dog on its own. The dog sees the location of a hidden reward and is also shown the location of an item that is necessary to access the item (e.g. a stick). The human helper’s knowledge of where either of these items is located is manipulated, and the dog’s behavior is measured to see whether the knowledge manipulation on the human helper resulted in the dogs adjusting how they interacted with the helper. Virányi et al. (2006) found that overall dogs were much more focused on the toy, and rarely signaled toward the location of the stick necessary to access the toy in any of the conditions. However, the dogs did signal the location of the toy significantly more when the helper was ignorant to the toy’s location. Thus, the dogs appeared to show behavior that somewhat corresponded with the helper’s knowledge state. Topál, Erdőhegyi, et al., 2006 tested a single highly trained service dog and reported stronger evidence of the dog’s behavior corresponding to the human’s knowledge state, but still concluded that this did not warrant conclusive evidence of dogs using communicative behavior based on human knowledge states. Similarly inconclusive results were found when researchers tested to see whether

dogs could learn that different human helpers could only play specific roles in helping them gain access to food from a puzzle apparatus (Horn, Virányi, Miklósi, Huber, & Range, 2012).

The strong tendency to look toward humans frequently in communicative contexts has been proposed to be a behavioral feature that distinguishes dogs from wolves (Kubinyi *et al.*, 2007). Specifically, when given a problem-solving task that is unsolvable on their own, dogs will alternate glances to a human observer both sooner and more frequently than wolves will (Miklósi *et al.*, 2003). However, this tendency has also been shown to be influenced by reinforcement contingencies (Bentosela *et al.*, 2008; Bentosela, Jakovcevic, Elgier, Mustaca, & Papini, 2009; Elgier, Jakovcevic, Mustaca, *et al.*, 2009); a dog's use of gaze to communicate with a novel human can be quickly increased or decreased depending on whether the behavior is reinforced with a desirable outcome or not, indicating flexibility in interspecies communicative behavior. The most extreme example of a learned dog-human communication was discussed in Section 4.1.4.2, where Sofia learned to use a keyboard to communicate with humans, pressing distinct lexigrams to indicate specific requests (Rossi & Ades, 2008).

Recently, researchers have started to look at both potential breed differences in dog-to-human communicative behavior as well as developmental changes, similar to what has been done previously in the “response-to-human-cues” research. Utilizing an unsolvable problem-solving task, Passalacqua *et al.* (2011) measured the gaze behavior of 2-month, 4.5-month, and adult dogs (>12 months of age). The researchers also separated dogs into three breed groups based on genetic clustering (Parker *et al.*, 2004): primitive, hunting/herding, and molossoid (i.e. mastiff-types). Passalacqua *et al.* (2011) provided evidence that dog-to-human communicative behavior was found in dogs as early as 2 months old. However, gaze duration and gaze alterations increased significantly with age, suggesting that the propensity to use such behaviors is altered during development. At 2 months of age, no breed differences in gazing were found, but results evaluating adult dogs' behavior found herding/hunting dogs gazed significantly longer at the person during the unsolvable task than did dogs from the other two breed groups. These findings are similar to those found in the “response-to-human-cues” literature (Gácsi, McGreevy, *et al.*, 2009), and again suggest artificial selection has impacted the communicative abilities of dogs toward humans.

Research has also compared trained guide dogs to pets in an effort to discover whether working-dogs are aware of their handlers' disabilities and thus compensate when trying to communicate with them. Such studies

have found minimal differences between guide and pet dogs in their solicitation behavior toward their handler/owner, except for the use of an audible licking behavior by the guide dogs, a potentially novel auditory cue that may have been reinforced in the guide-dog populations due to the sensory handicap of their human handlers (Gaunet, 2008, 2010).

*Dog-to-human communication synthesis and future directions:* Dogs use vocal communication, body positioning, and alternating visual glances to communicate requests to humans. The tendency to utilize such communicative behaviors distinguishes dogs from wolves, and contributes to their success in living with humans. Factors such as the dog's age, breed, population background, and current human handler appear to influence dogs' communication strategies. Future work on these factors as well as expansion into communication using different dog and human sensory modalities would seem to be likely next steps.

Passalacqua et al. (2011) is the only study that has explored the development of dog-to-human communication skills in individuals and potential breed differences between individuals. More developmental studies on dog-to-human communication are needed but results so far suggest dog-to-human communication skills develop at a later age than the ability to respond to human cues (which is also indirect evidence of the idea of "cognitive modalities", see Section 5). Research into differential maturation rates in different social cognition domains, and the corresponding development of correlations (or lack thereof) between different cognitive domains should be fruitful. Furthermore, in parallel with research on dogs' responses to human cues, future research could expand efforts on the dog-to-human communication into applied contexts. Understanding, and eventually manipulating, environmental, genetic, neurobiological, and social factors influencing the development of the dog-to-human communication skills would be useful for improving the handler-dog communication in the working-dog settings as well as establishing desired levels of the human-dog bonds between dogs and their owners.

#### **4.3.4. Social Learning**

The ability to learn through observation of others is a critical source of learning and information transfer among social species (Galef & Laland, 2005). Social learning under certain ecological conditions protects against the costs of trial-and-error learning that otherwise may be necessary to solve novel problems or adapt to new environments (Kubinyi et al., 2009; Zentall, 2006). The convergence of behavior between two individuals can be the

result of a number of alternative mechanisms ranging from social facilitation, where no learning is presumed, to full imitation, where a completely novel behavior is learned simply through the observation of a demonstrator (Zentall, 2001). These different forms of social learning have different requirements in terms of the information processed by the observer, what behavior is actually replicated (i.e. form and/or function), and the novelty of the behavior executed by the observer (Huber *et al.*, 2009).

One of the greatest challenges in social learning research is to exhaustively exclude simpler alternative explanations for the observed behavior (e.g. Occam's razor). Debate over the specific definitions of alternative social learning mechanisms and the exact identification of which mechanisms may explain the observed results are beyond the scope of this review (see reviews by Huber *et al.*, 2009; Zentall, 2001, 2006 for detailed discussion on this topic). Here, we instead categorize canine social learning studies into four broad categories: (1) learning through direct conspecific interaction, (2) spatial observational learning, (3) social learning via object manipulation, and (4) action-matching tasks. The first of these categories includes studies that specifically look at how direct interactions between conspecifics may facilitate learning. The other three categories investigate purely observational social learning (mostly with humans being the demonstrator), and these categories are distinguished based on the precision of the copying behavior they examine (see Huber *et al.*, 2009).

#### 4.3.4.1. Learning Through Conspecific Interaction

Several dog studies have focused on how learning may occur through observation and interaction with a conspecific demonstrator (e.g. Cooper *et al.*, 2003; Heberlein & Turner, 2009; Slabbert & Rasa, 1997). One stage in life where conspecific learning is likely to impact later behavior is during puppyhood, where maternal and littermate interactions may have important long-term life consequences (Crews, Fuller, Mirasol, Pfaff, & Ogawa, 2004; Melo *et al.*, 2006). Slabbert and Rasa (1997) investigated the role of maternal social learning effects in four different groups of German shepherd puppies. Groups 1 and 2 consisted of puppies born to mothers that were not trained in narcotic detection. Group 1 was weaned at 6 weeks, while Group 2 puppies received extended maternal care and were weaned at 12 weeks. Groups 3 and 4 were born to mothers that had been trained to detect narcotics, with Group 3 puppies being weaned at 6 weeks, while Group 4 received extended maternal care to 12 weeks. In addition, Group 4 puppies were given opportunities to observe their mother on walks where she was

asked to find and retrieve a drug-scented satchel (puppies were allowed to interact with the mother during searches, but the puppies themselves were not directly rewarded by handlers).

Despite getting only 2–3 of these additional 15-min exposures a week up to the age of 12 weeks, Slabbert and Rasa (1997) found that the Group 4 puppies performed at unprecedented levels when tested for their retrieval aptitude at 6 months relative to all other rearing groups. Of the Group 4 puppies, 85% of them displayed retrieval skills that were already at a level adequate for job selection, which had never been recorded before in the working-dog program in a puppy at 6 months of age. Of the other three treatment groups, only 18% displayed the minimal retrieval skills necessary for acceptance into narcotics dog training. Clearly, additional control groups would have been necessary to pinpoint the relative contributions of the different factors that could have led to this significant boost in performance in the Group 4 puppies (i.e. observational effects or genetic x observation interactions), and this study is in urgent need of replication. Nonetheless, this serves as putative evidence for the potentially strong effects that observational learning experienced as a puppy may have on future behavior. What is particularly interesting was the significant amount of time (i.e. 3 months) between the maternal observation sessions and the subsequent assessment of puppy retrieval skills; also, the puppy retrieval response occurred in a context that was different from the maternal demonstration environment, suggesting that these social learning effects may be quite robust.

Researchers have also examined the mechanisms of information transfer and how interacting with a conspecific demonstrator may facilitate social learning. Heberlein and Turner (2009) investigated the ability of dogs to learn about potential hidden food site locations from observing the search patterns of a conspecific. Demonstrator-dogs were first shown which of four screens a food item was hidden behind, and observer-dogs were then allowed to watch demonstrators search for the hidden food. Demonstrators always went to the correct location while the observer was present; however, the experimenters manipulated whether the demonstrator actually gained access to the reward or not. After their search, demonstrators were called back to their owner and allowed to interact with the observer-dog. How the two dogs interacted and the observer-dog's subsequent search behavior was then coded.

Heberlein and Turner (2009) found that while “snout contact” between demonstrators and observers during these interactions may not be necessary for information transfer of search success to occur, such contacts were

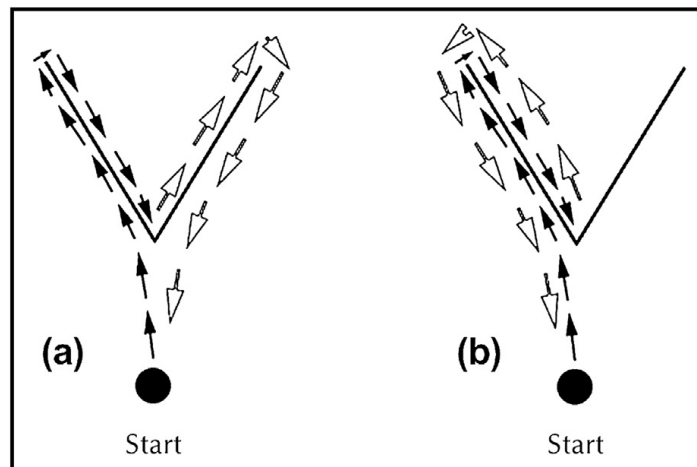
associated with the observers' subsequent search efficiency. Regardless of whether snout contacts occurred, if the demonstrator had just obtained the food reward, the observer-dog showed shorter search latencies to the same potential food location when given the opportunity to search the room themselves compared to when the demonstrator did not find food. However, if the demonstrator had obtained the reward and "snout contacts" then occurred, the observer-dog was more likely to initially search at the reward site and with shorter latencies compared to when no "snout contacts" occurred. The opposite trend was seen when the demonstrator was not given access to food; in this case, "snout contacts" were correlated with longer search latencies by observers to the same potential food location, possibly due to receiving information about the lack of access to food from the physical interaction.

#### 4.3.4.2. Spatial Observational Learning

Findings discussed earlier highlighted how dogs are able to learn to navigate a fence detour to reach a goal object on their own accord (see Section 4.1.7.3). However, much of the research using barrier-detour testing has also been conducted in the service of understanding the factors that influence social learning in dogs (e.g. Mersmann *et al.*, 2011; Pongrácz *et al.*, 2001; Pongrácz, Miklósi, Kubinyi, *et al.*, 2003; Pongrácz, Miklósi, Timár-Geng, *et al.*, 2003; Pongrácz, Miklósi, Timár-Geng, & Csányi, 2004).

As discussed earlier, dogs tend to perform less efficient-directed movements when starting outside a V-shaped fence detour as opposed to starting inside of it (Pongrácz *et al.*, 2001; Fig. 5.8). Pongrácz *et al.* (2001) also measured the impact of seeing a human demonstrator had on solving the inward barrier-detour task. Both owners and strangers were used as demonstrators, but regardless of whom the human was, observing a demonstration led to significantly improved (i.e. shorter) latencies in navigating the detour. This study did not specifically control for olfactory cues as a possibly explanation for the demonstrator effect but a follow up study found that dogs did not learn the detour if prevented from watching the demonstrator (Pongrácz *et al.*, 2004).

The dogs from the Pongrácz *et al.* (2001) study learned from human demonstration to navigate the detour faster but these dogs did not necessarily copy the human demonstrator's exact path. This is perhaps because the human demonstrator would detour around one side of the fence while placing the object and then detour around the opposite side to return to the dog's side of the fence (Fig. 5.9a). Such a detour may have resulted in an ambiguous signal in terms of directionality and thus led to the dogs not following the human's exact path. Pongrácz, Miklósi, Timár-Geng, *et al.* (2003)



**Figure 5.9** Illustration of the (a) two-sided (ambiguous), and (b) one-sided (unambiguous) detour demonstrations used in Pongrácz, Miklósi, Timár-Geng, et al. (2003). (Reprinted with permission of the American Psychological Association.)

found that having the demonstrators detouring in and out on the same side (Fig. 5.9b) had a significant impact on whether dogs followed their exact direction, particularly if the dogs had been unsuccessful on their own initially.

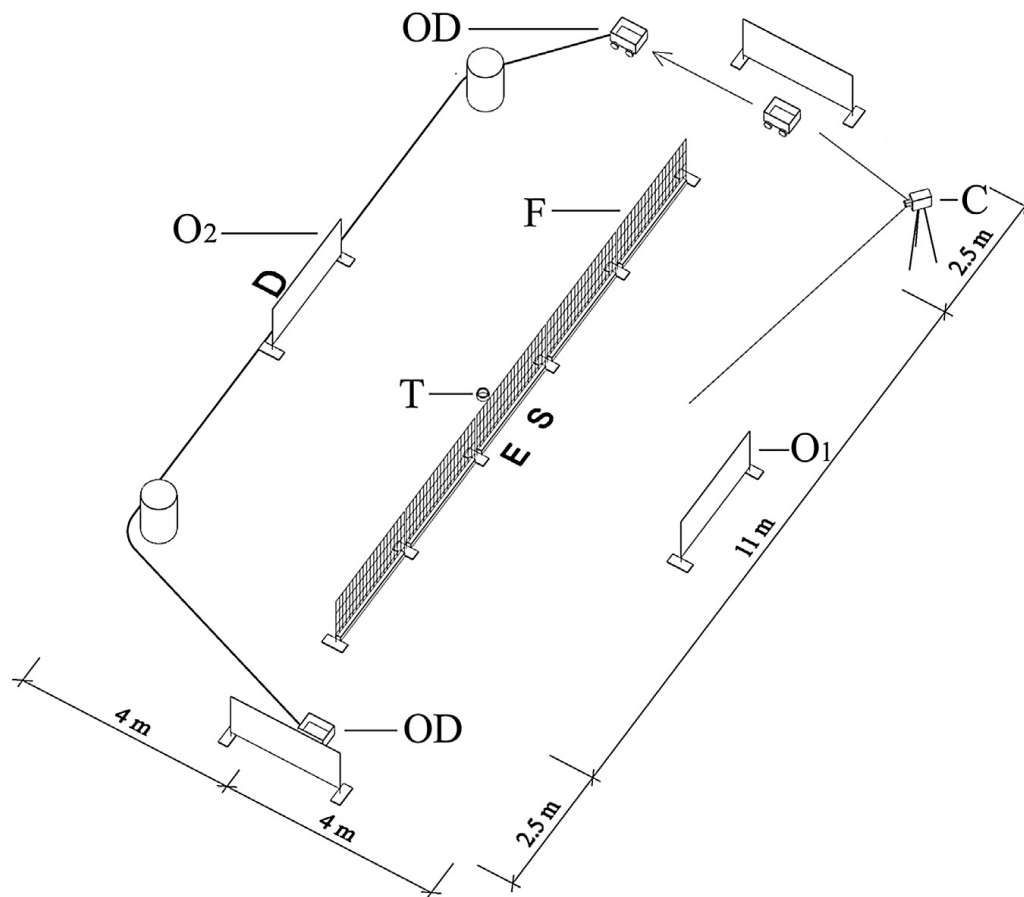
Observing a human demonstrator also helps dogs to learn new detours once previous route options are no longer available. Pongrácz, Miklósi, Timár-Geng, et al. (2003) found that without demonstration dogs had a tendency to perseverate toward a previously accessible but now blocked short cut. After watching a human demonstrator, dogs were able to learn to reroute their detour quicker than those who were not given the opportunity to watch a demonstration. Pongrácz, Miklósi, Timár-Geng, et al. (2003) also found that human demonstration can lead to inefficient behavior with regard to the immediate testing context; dogs that were shown through demonstration to follow a longer detour were less likely to take a short cut that was made available on ensuing trials.

As in other domains of social cognition, human ostensive cues during demonstrations seem to be key to facilitating social learning by dogs in spatial contexts. For example, Pongrácz et al. (2004) found that when the human demonstrator actively got the subject dog's attention through verbal encouragement during the demonstration, performance was better compared to when the human gave no verbal cues and simply was conspicuous about placing the goal object behind the detour-barrier. This finding supports the idea that certain social cues are important for interspecies observational learning to occur (though see Range, Heucke, et al., 2009 for an example of human ostensive cues inhibiting social learning).

However, ostensive cues may not be as important for intraspecific social learning. Pongrácz *et al.* (2004) found that dogs learned how to detour barriers from strange dog-demonstrators as effectively as from humans, but without the need of additional ostensive cues (i.e. verbal attention-getting calls). However, in this case the social status of the canine observer influenced its tendency to learn from watching conspecifics. When observer-dogs from multidog homes were tested, their determined social rank within the household was found to have no effect on their ability to utilize a human demonstrator, but did affect performance after viewing a unknown female dog complete the detour (Pongrácz, Vida, Bánhegyi, & Miklósi, 2008). Dogs deemed dominant in their home performed worse relative to dogs from single-dog homes and subordinate dogs, with subordinate dogs from multidog families showing the best performance. The effect of the observer breed may also impact social learning, but when 10 popular breeds were tested in the human-demonstrator paradigm no significant differences in detouring performance were found, even when these breeds were divided into three separate breed groups (Pongrácz, Miklósi, Vida, & Csányi, 2005). “Shepherds” were found to look at their owners more during the task, but this behavior did not affect their average latencies to solve the detour task compared to the other breed groups.

A more recent study evaluated the mechanisms that may contribute to how dogs perform on social learning detour tasks. Instead of using a V-shaped fence barrier, Mersmann *et al.* (2011) used a straight fence barrier as well as a pulley system that allowed the experimenters to move boxes remotely past the edges of the fence (Fig. 5.10). This set up created test conditions using inanimate objects as the “demonstrators” in addition to a test condition using human-demonstrators. Despite the lack of any social cues and that the “demonstrator” boxes only demonstrated a portion of the detour path, the dogs in this test condition, along with the dogs in the human demonstration conditions, outperformed control groups (who saw no detour demonstration). This led Mersmann *et al.* (2011) to conclude that stimulus enhancement can also lead to improvements in spatial detouring, and that social learning may not be solely responsible for dogs’ abilities to follow previously observed paths around detours. Mersmann *et al.* (2011) also found that despite the demonstration direction being one-sided, the observer-dogs showed no preference for following the demonstrators’ direction; this contrasts the results found in Pongrácz, Miklósi, Timár-Geng, *et al.* (2003). However, differences in the methodology (e.g. the barrier shape) between the two studies may explain some of the differences found.

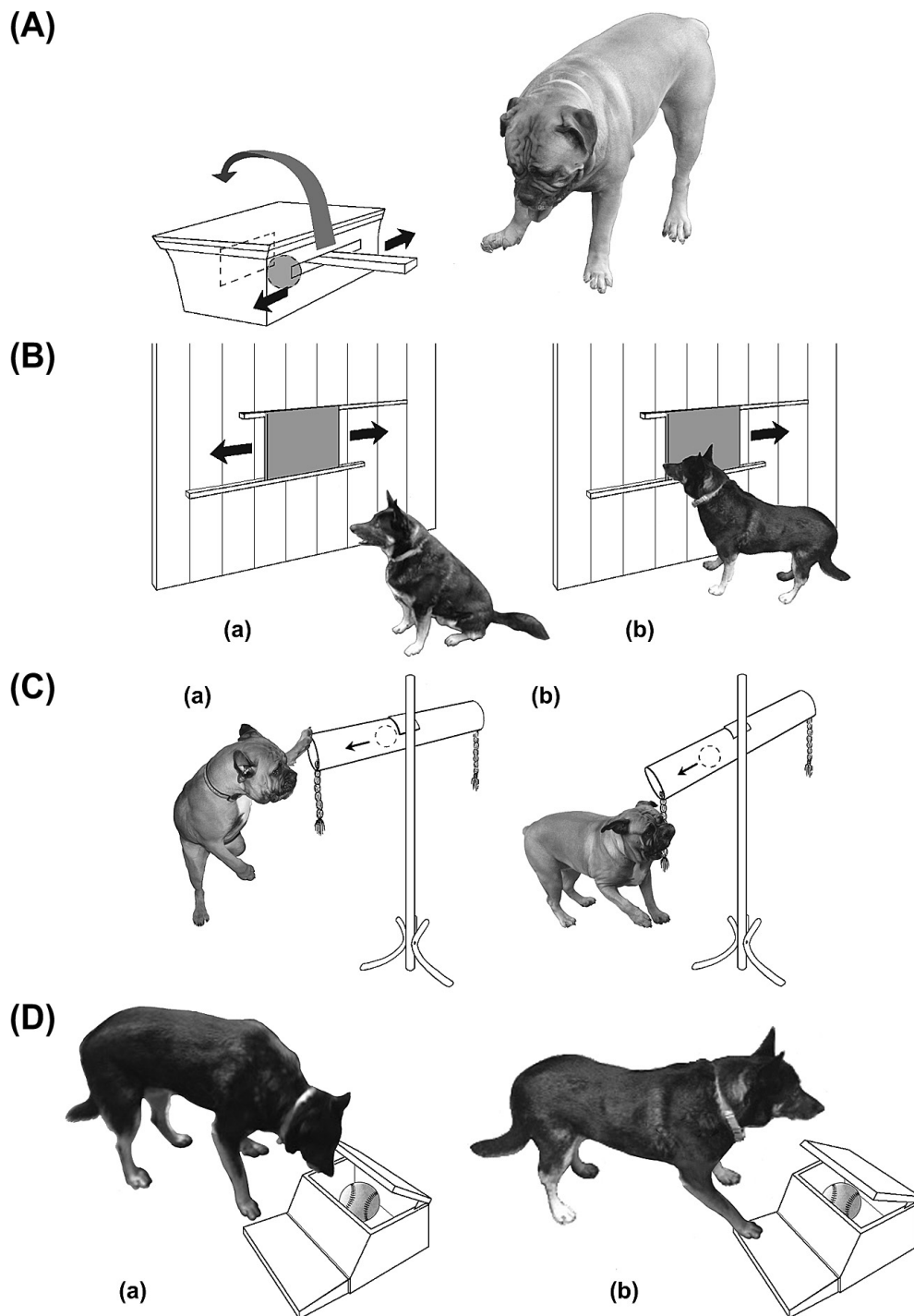




**Figure 5.10** Illustration of straight-fence detour task used in [Mersmann et al. \(2011\)](#). The experimenter (E) and the subject (S) stand on one side of the fence (F). On the opposite side of the fence is the target object (T). On trials where the human demonstrator (D) executed the fence detour, the demonstrator would walk out from behind one of the occluders (O<sub>1</sub> or O<sub>2</sub>) toward the middle of the fence before detouring around the fence to the middle of the opposite side. The human demonstrator would then walk behind the opposite occluder. On trials with the object demonstrator (OD) the experimenters would use the rope-pulley system to move one of the ODs perpendicular to the edge of the fence, starting on the same side as the experimenter and subject. (Reprinted with permission of Blackwell Verlag GmbH.)

#### 4.3.4.3. Social Learning via Object Manipulation

The ability of dogs to learn to manipulate objects in order to solve problems was discussed above (Section 4.1.5). Researchers have also utilized object manipulation paradigms to determine whether watching a demonstration improves a dog's ability to solve such a task. Based on the results of the few studies that have been conducted, the extent to which dogs are able learn how to solve an object manipulation task by watching a demonstrator seems to be limited. [Thorndike \(1911\)](#) originally tested whether his dogs were able to solve his puzzle boxes faster after watching another dog escape from them,



**Figure 5.11** Examples of the multiple-action apparatuses utilized in social learning via object manipulation studies. (A) The puzzle box used in [Kubinyi, Topál, et al., 2003](#). The ball can be released out the back (dotted lines) by moving the handle either to the left or the right, or alternatively, tilting the whole box. (B) The two-direction sliding door used in [Miller et al. \(2009a\)](#). (a) The dog witnesses the door being slid to either the left or the right, and then (b) the dog is given an opportunity to move the door in one

and was unable to find any evidence of observational learning regarding object manipulations. Yet, [Adler and Adler \(1977\)](#) reported evidence of such social learning, showing that puppies learned to pull a ribbon to gain access to food faster after watching a littermate learn the task than when not observing a littermate learn the task. More recently, [Kubinyi, Topál, et al. \(2003\)](#) tested the effect of a human-demonstrator on a dog's performance at manipulating a puzzle box to obtain a ball. The action of the human-demonstrator varied across treatment groups with some dogs seeing the experimenter move a lever that would release the ball (though not during the demonstration), while others saw the experimenter simply touching the lever or just the top of the box. Dogs in the control group did not see the experimenter contact the box at all. Despite these different demonstrations, most dogs were able to obtain the ball at least once out of four trials and there were no significant differences in the latencies of ball retrieval between the different treatment groups.

[Mersmann et al. \(2011\)](#) also manipulated how a demonstrator interacted with a target object, which in this case was a towel. Food was enclosed in a cage and to gain access to it the subject needed to pull a towel. Both human- and dog-demonstrators were used in this study and control treatments were included where observers witnessed demonstrators with food rewards but saw no object manipulation. [Mersmann et al. \(2011\)](#) found no difference between the treatment groups in their levels of success, which overall was low to moderate (only 40% of the subjects gained access to the food on at least one trial).

Instead of examining whether a demonstration affects the ability of a dog to solve a task requiring object manipulation, studies have also focused on the effect of the demonstration on how the canine subject interacts with the object. By studying the manipulation behavior of dogs after witnessing a demonstration, researchers attempt to understand what information dogs are processing and how this information may affect how they manipulate the object. To help answer this question, researchers have made frequent use of apparatuses that allow for multiple manipulations resulting in the same goal ([Fig. 5.11](#)); such devices can help differentiate the mechanisms that may be driving the observers' performance ([Huber et al., 2009](#); [Zentall, 2006](#)).



direction. (C) The manipulation apparatus used in [Pongrácz et al. \(2012\)](#). A ball is loaded in the apparatus, and the dog can either (a) tilt the tube directly or (b) pull down on one of the ropes. (D) The testing apparatus used in [Marshall-Pescini et al. \(2008\)](#). The testing apparatus contains a reward, and can be opened directly by (a) lifting up the lid, or by (b) pressing down on the step pad.

Some results indicate that dogs are influenced by where a human-demonstrator manipulates the object. With the puzzle box used in Kubinyi, Topál, *et al.*'s (2003) study, a ball could be released by pushing a lever in one of two directions, but could also be released in other ways (e.g. tipping the entire box; Fig. 5.11A). Even after controlling for potential odor cues, all dogs that witnessed a human-demonstrator pushing the lever of the box to gain access to the ball touched the handle at some point during their test trials, compared to only half of the dogs that saw no demonstrator contact with the box. In addition, 60% of the dogs that saw the demonstrator push the lever to release the ball used the handle themselves to release the ball on all three test trials, while only 10% of the "no-demonstrator-contact" dogs did this. However, the dogs showed no preference for pushing the lever to the side that was demonstrated.

A side-matching preference was found in Miller *et al.* (2009a) who used both human and dog demonstrators in a bidirectional control procedure where subjects were required to push a sliding screen to gain access to the reward, and the screen could be pushed either to the left or the right (Fig. 5.11B). With this procedure, experimenters can code whether the subject dog moves the screen in the identical direction as the demonstrator. Based on a study that found direction matching in pigeons (Klein & Zentall, 2003), Miller *et al.* (2009a) used different demonstration conditions, including a condition in which the screen moved without overt manipulation from the demonstrator (i.e. emulation). The results for this study differed depending on the species of the demonstrator. Dogs showed the highest direction matching after seeing a canine demonstrator move the screen. This effect dropped to chance levels when the dog was present, but during the demonstration the screen was moved by an unseen force (i.e. remotely by the experimenters). When the human-demonstrator moved the screen, the observer-dogs matched the direction witnessed only marginally above chance levels; however, significant levels were reached in the human-emulation group, where the human stood in front of the screen and some unseen forced moved it in one direction. Looking at the first-trial performance the dog-imitation group did significantly better than the human-emulation group. These results are somewhat equivocal, but do provide some evidence that dogs pay attention to the direction an object is manipulated. This study also suggests that dogs can learn to manipulate objects through emulation, highlighting the potential importance of environmental cues outside of the demonstration per se (i.e. the

demonstrator's movements may be inconsequential). Future work is needed to clarify these results.

Using a two-action test, in which the demonstrator performs one of two different ways to successfully manipulate an apparatus, [Pongrácz, Bánhegyi, and Miklósi \(2012\)](#) also found evidence of demonstration type on how subject dogs' manipulated the apparatus themselves. In this two-action test, the test apparatus was an open tube that was suspended by a pole, attached at the tube's center. The tube could be balanced horizontally to hold a ball, and could be tilted by pressing down on either end, or by pulling down on one of the ropes attached to either end (Fig. 5.11C). Dogs showed an initial preference to directly contact the tube to release the ball, as opposed to pulling on the rope. However, when the dogs witnessed a human-demonstrator using the rope, the dogs were more likely to use the rope than dogs that had gotten no demonstration. Dogs showed no preference for manipulating the same side of the tube as the demonstrator, and altered side choice over three trials even when successful. [Pongrácz et al. \(2012\)](#) also examined the influence of home social rank on observers' ability to learn from watching a conspecific. Dogs considered "dominant" in multidog home environments were more successful at obtaining the ball from the tube than submissive dogs after seeing a demonstration, regardless of the demonstration type.

Others have not found differences in behavior between human demonstration conditions involving separate routes of object manipulation. In [Marshall-Pescini et al. \(2008\)](#) the demonstrator could open a feeding box by either pulling up on the lid or by pressing down on a step pad (Fig. 5.11D); no differences were found among groups of dogs that observed the different types of human demonstration. However, dogs in the [Marshall-Pescini et al. \(2008\)](#) study tended to have an overall difficult time with their puzzle task (only 45% of dogs were successful). This result also may be due to one manipulation type being heavily preferred by the dogs because opening the lid with their nose may have been more natural than pushing down on the step pad with their paw. Furthermore, in contrast to [Kubinyi, Topál, et al. \(2003\)](#), [Range, Heucke, et al. \(2009\)](#) found that dogs that performed well after watching a demonstrator use a lever to open the same puzzle box did not show stimulus-specific learning, and instead simply spent more time contacting the entire box, not just the front panel and lever. With such contrasting results, it is clear that many issues remain to be resolved regarding what is learned from witnessing object manipulation demonstrations and how dogs might use this information to improve task efficiency.

#### 4.3.4.4. Action-Matching Tasks

A number of studies have looked into the capabilities of dogs to process the actions of a demonstrator and visually match their behavior (e.g. Range, Virányi, & Huber, 2007; Topál, Byrne, Miklósi, & Csányi, 2006). These studies have been done in the context of searching for evidence of behavioral prerequisites for imitative behavior, and most have found evidence of action matching (e.g. Huber *et al.*, 2009; Range, Huber, & Heyes, 2011; but see Kaminski, Nitzschner, *et al.*, 2011). However, investigators have offered varied explanations for their results with respect to imitation (Range, Huber, *et al.*, 2011, Range *et al.*, 2007) versus alternative behavioral mechanisms (Topál, Byrne, *et al.*, 2006). This debate largely derives from differences in how investigators define the term “imitation” as well as the range of behavioral outcomes that this phenomenon encompasses (see Byrne, 2002). For example, does the exact action of the demonstrator have to be mimicked or is it more important that the behavioral outcomes converge? A detailed discussion about what differentiates imitative behavior from potential alternative mechanisms is beyond the scope of this review (see Huber *et al.*, 2009; Kubinyi *et al.*, 2009; Zentall, 2001, 2006). Here we give an overview of the findings related to action matching in dogs.

Two studies have explicitly measured how well dogs are able to learn to respond to a matching command based on a human trainer’s trial-specific behavior. These two studies have also measured how well these dogs are capable of generalizing this matching concept to observed behaviors not specifically included in the training procedures. Topál, Byrne, *et al.* (2006) were the first to use the “Do As I Do” training procedure established by Hayes and Hayes (1952). Specifically, Philip, a previously trained service dog (Philip was also studied in Topál, Erdőhegyi, *et al.*, 2006), was taught to match previously learned behaviors to human behaviors that were grossly similar on the single command “do it” (e.g. “jump in the air” had the human actually jumping, while Philip was required to raise both front paws simultaneously). Philip was able to match actions upon command as well as generalize commands by showing moderate success in displaying previously known behaviors that grossly matched novel actions demonstrated by the trainer (e.g. trainer walked a circle around another human, so Philip walked a circle around this same human). Philip’s performance was better on object-oriented or transitive actions (i.e. direct interactions with objects such as “move shoe”) versus intransitive body movements where the goal behavior was more opaque (i.e. “crawl in the cupboard”). Topál, Byrne, *et al.* (2006) also tested Philip’s ability to match action-pattern sequences through

an object movement task. In this task, there were six locations where multiple bottles were placed. Philip watched as a demonstrator walked to one location, picked up a bottle, and moved it to one of the other five locations. After the demonstration was done, the command “do it” was given to Philip. Philip showed some level of understanding in terms of action-matching observed sequences of behavior in that he went to the starting position and attempted to move a bottle to the new goal location more than would be expected by chance alone in repeated trials.

A similar experiment was conducted by [Huber et al. \(2009\)](#), this time with a female Weimaraner named Joy. Again, with extensive training Joy was capable of following the “do it” command by executing behaviors that subjectively matched the behaviors demonstrated by the trainer. [Huber et al. \(2009\)](#) also measured how well Joy might be able to generalize this command to different behaviors varying in their novelty. When shown “novel” actions in which one of Joy’s previously trained behaviors could act as a clear analog, Joy was capable of matching. Joy had more trouble with multiple action sequences, often only attempting to match the last action seen. If the demonstrator used any “exotic” actions (i.e. actions where no obvious analog existed in Joy’s know behavioral repertoire), Joy performed poorly. Joy showed some capacity for matching the function of demonstrated behaviors (e.g. picked up a towel with her mouth after watching the demonstrator use his/her hand), performing best when the demonstrated actions involved object-oriented behaviors, but made no attempt to match intransitive movements with no clear goal. Again, the level of appropriate inference regarding social learning mechanisms underlying Philip and Joy’s action-matching depend on one’s definition of imitative behavior. For example, how well does the action have to match the behavior demonstrated to achieve “imitation”? Does it still count as imitation if the behavior executed was previously learned? Further studies using larger samples (logistics notwithstanding) may allow these results to be extrapolated to other populations of dogs, and could also allow for the development of test paradigms that provide novel, powerful training methods in working-dog programs.

Some dog studies have focused on whether dogs show a tendency to match the form of a demonstrator’s action spontaneously. Here test paradigms have been adopted in which various discrete body actions can be used to manipulate the same object. Overall, dogs may be able to perceive variations in the demonstrator’s behavior, but they do not seem to spontaneously match the form of a demonstrator’s behavior. Instead dogs show a response bias for

their own particular form of action and follow through with that response regardless of the demonstrator's action (Mersmann *et al.*, 2011; Range, Huber, *et al.*, 2011). However, Range, Huber, *et al.* (2011) found that dogs could be trained to differentially respond based on a human-demonstrator's form of action (i.e. using head or limb). With intensive training, dogs learned to either open a door with their paw or their head. The dogs were then trained to match or counter-match a human who opened the door using one of those two same responses. Dogs in the matching group were rewarded for matching the form of the demonstrator on each trial, and dogs in the counter-matching group were rewarded for executing the opposite behavior. Dogs in the matching group reached the initial training criterion faster, indicating that matching behavior may be seen as more relevant and therefore easier to develop through associative learning. The strong influence of associative learning was further supported by the low success rate of the counter-matching group when the contingency was reversed (i.e. these dogs were now required to match the demonstrator's behavior). It is important to note that without extensive training, including the use of verbal cues to first establish the demonstrator's behavior as a discriminative cue, the dogs in Range, Huber, *et al.* (2011) did not spontaneously exhibit matching behavior.

Range *et al.* (2007) were interested in discovering what factors might lead dogs to match behavior in some situations but not others. Children have been found to selectively imitate others based on perceived situational constraints placed on the demonstrator (Gergely, Bekkering, & Király, 2002). For example, if a demonstrator turns on a light switch with their head while their hands are full, children typically will not copy this behavior, instead opting to use a more "efficient" behavior and simply use their hand to switch on the light when given the chance. However, children will be more likely to use their head if the demonstrator's hands are not occupied, and therefore there is no obvious reason for using the "inefficient" behavior. Range *et al.* (2007) were interested in testing whether dogs might also selectively imitate based on the context in which a demonstrator's behavior occurs. In this study, the observer-dogs witnessed a demonstrator-dog using its paw to pull down on a handle on a hanging contraption to release food, which the observer-dogs were allowed to eat. Without demonstration, subject dogs preferred to pull down on the handle with their mouth, thus Range *et al.* (2007) considered this action as more "efficient" than using their paw. During the demonstration trials,



some subjects observed the demonstrator-dog manipulate the apparatus with its paw while it had a ball in its mouth, thus observers might infer that this is the reason for why the demonstrator-dog did not use the more “efficient” action of using its mouth to pull down on a handle. For other observer-dogs the demonstrator used its paw but had no ball in its mouth, and thus the authors argued that the observer-dogs may have perceived this action as “inefficient.” Similar to human children, dogs that witnessed the “inefficient” behavior (demonstrator-dog using their paw while having their mouth free) were significantly more likely to use their paw on the initial test trial than dogs who witnessed the demonstration where the demonstrator used its paw because its mouth held a ball, thus providing preliminary evidence that dogs may choose to imitate conspecifics in some situations, but not others. However, overall the dogs in [Range et al.'s \(2007\)](#) study showed a preference to contact the handle with their mouth on test conditions and after the initial test trial, there was no significant difference between the observer-dog test groups in terms of their rate of paw versus mouth use. More recent attempts to replicate these results have been unsuccessful ([Kaminski, Nitzschner, et al., 2011](#); though see [Huber, Range, & Virányi, 2012](#)).

*Social learning synthesis and future directions:* Findings emerging from the social learning literature vary depending on the learning context. Positive results have been obtained in terms of dogs learning socially through conspecific interactions and in terms of dogs learning spatial detouring from demonstrators but results are more mixed with regard to social learning during object manipulation and action-matching demonstrations. More research is needed to first establish the environmental and social contexts that facilitate or inhibit social learning. At the same time, the mechanisms (e.g. stimulus enhancement, social facilitation, emulation, imitation) that contribute to social learning are far from known. Future efforts need to be made toward coming to a consensus in terms of how to evaluate the mechanisms potentially involved in positive social learning outcomes as well as identifying when dogs are capable of spontaneously utilizing social learning on their own versus being trained to follow a demonstrator's actions. This type of research would be especially useful in working-dog applications. Studies such as those done by [Slabbert and Rasa \(1997\)](#) hint at the profound effect that socially facilitated learning could potentially have on canine behavior in applied contexts. Incorporating social learning paradigms into training routines could have strong practical applications in many working-dog programs. Future research should aim to understand the

effects of incorporating social learning opportunities into training methods, both in pet and working-dog contexts.

#### 4.4. Generalizations and Recommendations for Future Studies on Social Cognition

1. *There is a strong need for further replication of results, particularly in the domain of social learning.* Dogs have been shown to utilize human communicative cues in cooperative contexts, respond differentially to human cues related to human attention state, and produce communicative signals in order to influence humans' behaviors. Nevertheless, there are a number of areas where our knowledge is based on 1–3 studies (e.g. development of dog-to-human communication) and replication studies are clearly needed.

The need for replication is most evident when reviewing the social learning literature. Currently, researchers interested in studying social learning in dogs are working to refine cognitive explanations for the observed behaviors and design appropriate paradigms to test specific social learning mechanistic hypotheses (e.g. social facilitation versus imitation; action matching versus matching goal outcomes). Overall, inferences from social learning studies are, at present, difficult to ascertain (e.g. Miller *et al.*, 2009a; Range, Heucke, *et al.*, 2009), and further social learning studies using refined paradigms that allow for distinctions between underlying mechanisms should continue to bear fruit.

2. *Consensus of methods and development of theory is needed to test relative phylogenetic and ontogenetic contributions to canine cognition.* In recent years, there has been much debate over the handful of studies aimed at measuring the development of the ability to respond to human cuing and studies measuring differences between dog populations related to differences in ontogeny (e.g. pets versus shelter dogs). Such studies have the potential to further our understanding of the likely interplay between phylogenetic and ontogenetic effects but researchers must come to some agreement in terms of the best methodologies for making accurate comparisons. Such standards need to involve the types of human gestures that should be used as benchmarks and analytic approaches likely to yield meaningful results.
3. *Studies on responses to human cues should look to expand beyond the two-object choice paradigm.* Nearly all the studies looking at response to human cues in dogs have utilized the same two-choice paradigm. Research has recently begun to develop this paradigm further to incorporate features

that are more ecologically realistic, such as increasing the number of potential reward sites, varying the distances between potential reward sites, and including cues that are more difficult to interpret such as indirect signaling (Lakatos et al., 2012). Such research is the logical next step because it aims to measure these social skills in more realistic scenarios, while at the same time testing the limits of these abilities empirically.

4. *Research on perspective taking does not need to focus solely on underlying cognitive mechanisms.* The debate over the cognitive mechanisms underlying observed perspective taking phenomena in dogs is likely to preoccupy interested researchers for the immediate future with some calling for novel paradigms to better answer this question (Horowitz, 2011). However, even if researchers are agnostic regarding the underlying mechanisms, other gaps in knowledge can be explored. For example, future research can aim to determine when perspective taking abilities first appear during development, with the general aim of furthering our understanding of canine cognitive development. Additionally, future research should identify social or environmental factors that influence the development of perspective taking in dogs, and identify other potential differences between sexes, breeds, or dogs with different background experiences. Perspective taking social cognition research could have significant fundamental and applied outcomes for dogs in human society.
5. *Social cognition research should expand into applied contexts.* Fundamental social cognition research largely focuses on how dogs respond effectively to human cues, communicate back to humans, and learn from the actions of both humans and other dogs; these are all critical aspects of dogs' utility in human society. To date however, little social cognition work has been extended to the working-dog populations, and efforts to understand how fundamental knowledge can be directly applied to improving outcomes in human-dog interactions are rare. Maternal and littermate observational effects early in life seem particularly worthy of study (e.g. Slabbert & Rasa, 1997). Additionally, incorporating social cognitive exercises into standard socialization practices may permit improvements in desired human-dog bonds (Howell & Bennett, 2011b). Potentially powerful cross-fertilizations between social cognition researchers and applied dog interests (e.g. governments, working-dog programs, breeders, etc.) have yet to achieve their potential.
6. *More studies are needed on individual differences in dogs' tendencies to follow human cues as well as other areas of social cognition.* As was found in the domain of nonsocial cognition, little attention has been paid to consistent

differences among individuals in their performances on social-cognition experimental tasks. There are a number of examples of researchers publishing the individual performances of their subjects, and in some cases tracking individual performances on a trial-by-trial basis (Agnetta *et al.*, 2000; Miklósi *et al.*, 1998; Udell, Giglio, *et al.*, 2008). Yet, even in these articles, such differences simply result in a small amount of posthoc discussion. Individual level analysis is typically limited to counting the number of individuals who performed at above chance levels; otherwise such differences are treated analytically as statistical noise. More explicit research on individual differences in cognitive abilities and/or differences in strategy choice could have considerable theoretical implications and real-world applications. For example, if individuals consistently differed in their cognitive ability, and these abilities affected a dog's job success, cognitive paradigms could serve as the basis for new tools for selecting working-dogs. Future research should look to further document the consistency of individual differences in social cognitive ability (e.g. Gácsi, Kara, *et al.*, 2009), as well as begin to explore whether and how individual performance correlates across different cognitive domains. Given the theoretical, applied, and comparative importance of research on individual differences, we next introduce the implications of this topic for dog cognition research.



## **5. INDIVIDUAL DIFFERENCES IN COGNITION: MEASUREMENT, COGNITIVE CORRELATIONS, AND INTERACTIONS WITH PERSONALITY**

A common theme throughout this review is the need for more research on individual variation in dog cognitive abilities. Variation is ubiquitous in nature, and individual differences in cognitive abilities and strategies/choices have now been described in several dog studies (e.g. Aust *et al.*, 2008; Leonardi *et al.*, 2012; Nippak *et al.*, 2003; Range, Möslinger, *et al.*, 2012). Unfortunately, evidence remains scant and explicit research on the subject lags behind other closely related dog research fields (e.g. dog personality studies: Fratkin *et al.*, 2013; Jones & Gosling, 2005). We suggest that significant insight into the development and predictability of cognitive outcomes in general may be achieved by future studies that explicitly study cognitive development at the individual level. Below we highlight research that could provide a helpful starting point for researchers interested in individual differences in dog cognition.

1. *Studies could examine the generalizability of their cognitive measures.* Measuring individual differences in cognition in animals is not trivial. Therefore, future individual difference research would be well advised to start by focusing on basic questions regarding the generalizability of cognitive measures; generalizability could be assessed across such varied facets as the observers taking the measurements (i.e. interjudge agreement), the ages of the dogs, the times of day when the tests are performed, and so on (see Burghardt et al., 2012; Caro, Roper, Young, & Dank, 1979; Kaufman & Rosenthal, 2009). An important first step has been made in this regard by Gácsi, Kara, et al. (2009) who found evidence that their measurements of dog responses to human cues appeared to be reliable over time (i.e. they were generalizable across different periods of the dogs' life). Research on the generalizability of individual-level measurements themselves would provide a strong measurement foundation for future dog cognition studies. For example, the likelihood of detecting relationships between cognitive traits and other variables would be improved by making the tests more reliable. Studies that go through the effort of establishing reliable measures will be better placed to understand how cognitive abilities relate to other physical and behavioral characteristics and, subsequently, to investigate the underlying mechanisms responsible for observed cognitive phenomena.
2. *Cognitive modalities and resulting cognitive correlations (if any) should be identified.* Modality is a central element in current evolutionary thinking (West-Eberhard, 2003); implicit in this idea is that several distinct cognitive processes can be measured in the same individuals. With a few notable exceptions (e.g. Clarke et al., 1951; Frank, 2011; Nippak & Milgram, 2005; Scott & Fuller, 1965), the vast majority of canine cognitive research has measured performance of individuals on only one cognitive task at a time (e.g. Fiset et al., 2006; Kowalska, 1997; Range et al., 2007). To date, research that has taken an individual-level approach to examining correlations among cognitive abilities has been scarce (e.g. Head et al., 1998) and no researchers have correlated individual cognitive ability across multiple cognitive domains. However, research from other fields indicates that such correlations may provide significant insights into the modular organization of cognition in dogs.

Over the last century, individual differences in human cognitive abilities has been a central topic of interest with a strong focus on how general cognitive mechanisms are organized and how they influence performance across multiple cognitive tasks (Jensen, 1998). Individual

differences' research has led to the consistent finding throughout the human cognitive literature that there exists a general intelligence factor, or "g" factor, which has been estimated to explain up to 50% of the variance among individuals on several different intelligence tests (Jensen, 1998; Plomin, 1999). In this case, it appears that: (a) cognitive modality is lacking in human intelligence processes, or that (b) several different cognitive modes are positively correlated with one another.

However, little is known about how different facets of cognition correlate in nonhuman animals. Some research suggests that nonhuman analogs to the *g* factor do exist (Plomin, 2001). A number of researchers have tested laboratory rats and mice on varying batteries of cognitive tests and found that individual performance results across these tasks show a positive correlation with one another (Anderson, 1993; Galsworthy, Paya-Cano, Monleón, & Plomin, 2002; Locurto & Scanlon, 1998; Matzel *et al.*, 2003). Thus, it appears individual performance on all of these different tasks can be explained by a single primary factor. More recently, research investigating nonhuman cognitive structure has been expanded to include nonhuman primates. Herrmann, Hernandez-Lloreda, Call, Hare, and Tomasello (2009) tested chimpanzees on a wide battery of tests that measured physical, spatial, and social cognitive skills; no single primary factor was found in this case. Instead, a two-factor model best described the results with social and physical cognition tasks loading on one factor and spatial tasks loading on the other. As suggested by the authors of this study, one of the potential reasons for this inability to find a primary general cognitive factor was the lack of performance variability on some of the tasks (also see Herrmann & Call, 2012).

However, a positive correlation between modular components of cognitive information processing is not the only possible outcome. Broadly speaking, there are three possible patterns of relationships among different cognitive components: A positive relationship (suggesting a general cognitive ability driving performance across tests, e.g. "g"), a general lack of relationship (suggesting independent cognitive domains), and a negative relationship (suggesting that strong cognitive performance in one domain comes at the expense of performance in other domains, perhaps driven by cognitive limitations or load constraints; Chittka, Skorupski, & Raine, 2009; Hills & Hertwig, 2011; Shettleworth, 2012). Developing test batteries that allow the individual performances of dogs to be tested across a range of cognitive domains will be critical to improving our understanding of how cognitive processes are structured in dogs.

In addition, researchers will need to distinguish between any individual cognitive limits and individual strategy preferences. In other words, an individual dog may not perform well on a particular cognitive task not because they cannot, but because they came to the task with an initial predisposition to using a particular cognitive strategy, which does not lend itself to the experimental paradigm at hand.

3. *Future research should look to further explore how dog personality may interact with dog cognition.* Psychologists and biologists have hypothesized that differential performance on cognitive tasks may also be the result of consistent interactions between a subject's personality and cognitive ability. Carere and Locurto (2011), drawing on the work of Ivan Pavlov, theorized that dogs with different personality types may differ in terms of their excitatory and inhibitory learning ability (Pavlov, 1906). For example, Pavlov claimed that based on the properties of the canine nervous system, there were four main personality types: Excitable, Lively, Quiet, and Inhibited. Carere and Locurto (2011) note that Pavlov made predictions about how different personality types may fare in different types of learning tasks. For example, an Excitable dog may show rapid learning skills when given an excitatory learning task, but then struggle on an inhibitive learning task. Carere and Locurto (2011) draw on these ideas to suggest that personality measures may allow us to better understand the variation in cognitive performance that is often observed in a species (e.g. Fabrigoule & Sagave, 1992; Gácsi, Kara, et al., 2009; Osthaus et al., 2010) by providing personality as a factor that can be included in statistical analysis.

Sih and Bell (2008) discuss the topic of cognition and personality interactions from a behavioral ecology perspective. These authors use the terminology "behavioral syndromes," which they define broadly as suites of correlated behaviors that are expressed by an individual through time, across situations (e.g. foraging in different habitats) and/or contexts (e.g. feeding/mating). A particular emphasis in the study of behavioral syndromes is placed on understanding behavioral constraints, which may result in suboptimal behavior in some conditions. Behavioral differentiation between individuals within a population is also highlighted, with individuals having different "behavioral types." Each type has its own strengths and weaknesses in terms of evolutionary fitness. Similar frameworks could be used to measure the same individuals in different cognitive tasks to help explain variations in behavior outcomes and identify possible cognitive tradeoffs. Different "types" of

learning styles or cognitive strategies may be mutually exclusive with one another but present unique adaptive advantages in certain contexts while resulting in suboptimal performance in others (Budaev & Brown, 2011; see also Stamps & Groothuis, 2010). For example, individual dogs that excel in responding to social cuing may be more constrained with regard to learning nonsocial discriminatory cues; likewise, dogs that excel at social learning may struggle with independent problem-solving. Sih and Bell (2008) explicitly point to a dearth of research investigating how learning styles correlate across multiple contexts and how cognitive performance may interact with an individual's personality "type" (for additional discussion on how animal cognition might be incorporated into personality research see Sih & Del Giudice, 2012). Dogs in particular present a unique opportunity for exploring such ideas. The extensive research, already conducted in the fields of canine personality (Jones & Gosling, 2005) and cognition, makes the dog an excellent species to explore these hypotheses. Indeed, some researchers have started to incorporate temperament-related measures such as sociability (Jakovcevic, Mustaca, & Bentosela, 2012) and impulsivity (Wright, Mills, & Pollux, 2012) as predictive variables for performance on cognitive tasks.

4. *Future research should aim to explore the role individual differences in dog cognition in applied settings.* Individual cognitive measures have the potential to provide significant advances in applied settings. Dogs present a unique opportunity to measure the predictive validity of cognitive measures in working-animals. For example, professional working-dog programs are continually attempting to develop measures that will improve their selection of successful dog candidates (e.g. Sinn *et al.*, 2010; Wilsson & Sinn, 2012); incorporation of cognitive paradigms may provide unique and powerful bases for selecting dogs likely to perform their jobs effectively. In the human-intelligence literature, *g* has been demonstrated to have strong predictive validity in terms of individual job outcomes in humans (Schmidt & Hunter, 2004), pointing to the potential usefulness of multitest cognitive paradigms for selecting the working-dog. Additionally, identification of individual cognitive differences (if cognitive "types" are common) could enable the working-dog professionals to tailor training methods to improve outcomes for dogs and humans alike. Finally, if different behavioral-enrichment interventions are differentially effective depending on an individual's cognitive strengths then cognition studies could enhance



animal welfare by directing interventions to animals that suit their individual cognitive strengths and style.



## 6. SUMMARY AND CONCLUSIONS

Dogs play varied vital roles in human society. The benefits of dogs is clearest in utilitarian roles, such as substance detection and disability assistance but dogs also provide more subtle benefits to humans, such as contributing to humans' emotional well-being (McConnell, Brown, Shoda, Stayton, & Colleen, 2011; Zilcha-Manu, Mikulincer, & Shaver, 2012). As a consequence of the dog's integration into human society, researchers have become increasingly interested in understanding the cognitive abilities that allow dogs to thrive in the numerous roles humans give to them. Here we provide what to our knowledge is the most comprehensive summary and synthesis of the rapidly growing field of dog cognition. Our aim was to identify the major trends, findings, and gaps in the field. Based on this review, we now conclude by making a number of recommendations for future research on canine cognition.

1. *Expand cognitive test-paradigms to include multiple sensory modalities.* Currently, there is a strong tendency in the literature to use visual-based test paradigms. Roughly 74% of the studies reviewed here made use of visually oriented tasks. In reality, combinations of visual, acoustic, gustatory, tactile, and olfactory senses are most likely contributing to perceptual processes in dogs (relative contributions of each sense may vary across conditions, populations, breeds, sexes, or even individuals); future research should strive to understand how dogs' perceptions and mental representations of the world around them are shaped by multiple sensory-cognitive modality components.
2. *Expand dog cognition studies to populations of shelter and working-dogs.* Roughly 13% of the reviewed studies used subjects that were either working-dogs or dogs in a shelter, while around 72% of the reviewed studies used pets volunteered by their owners. Considering the large number of research programs focused on working-dogs and the immense shelter-dog population, collaborations between cognitive researchers and such working- and shelter-dog programs are an excellent opportunity for the cross-fertilization of ideas and for gaining significant insights related to both fundamental and applied interests.
3. *Replicate studies and increase sample sizes.* In many cases current knowledge of particular cognitive domains in dogs is based on the results of 1–3 studies, and broader inferences to dog populations in general are limited

by the small sample sizes, which are frequently smaller than 10. In some cases, we believe the small number of studies may contribute to the disagreements over results evident in some subfields of dog social cognition. For canine cognition to build on its promise, a stronger empirical foundation is needed in terms of multiple independent replications of basic effects, preferably using substantial sample sizes (Ryan, 2011). The collaborations with working- and shelter-dog programs noted in the preceding recommendation may be particularly helpful in this respect.

4. *Expand studies on developmental processes.* Only about 13% of the research summarized here focused on dogs that average younger than 1 year. Additionally, only around 13% of studies used longitudinal or cross-sectional research methods to examine age differences. Consequently, it is difficult to characterize the main findings regarding the developmental processes and developmental selection (Bateson, Hofer, Oppenheim, & Wiedenmayer, 2007) involved in canine cognition. Maturation of cognitive features as well as developmental features such as plasticity and canalization are critical components of understanding any trait (Tinbergen, 1963). This knowledge is especially important in the case of dogs where cognitive features and differences between individuals determine their suitability for work or companionship. Therefore, future research should aim to understand the developmental trajectories, as well as the key genetic, neurobiological, environmental, and social factors that influence the development of cognitive features identified here. With the dog genome now mapped (Parker *et al.*, 2004), interdisciplinary approaches incorporating phenotypic development with functional genomics could prove to be particularly illuminating.
5. *Expand studies on individual differences.* Due to substantial theoretical and practical implications of research on individual differences (see Section 5), we urge investigators to begin to explore this topic in detail. Research on the consistent individual differences in cognitive skills and choices regarding cognitive strategies stands to contribute to the growing interest in individual differences and specializations in evolution in general (Dall *et al.*, 2012; Olson, 2012; Pigliucci, 2003; Thornton & Lukas, 2012).
6. *Expand studies on cognitive modalities.* Do broad, general cognitive processes explain cognitive performance across multiple situations in dogs, or are cognitive facets organized in a more modular fashion? Developing methods for studying the same individuals on multiple tasks that require action from supposedly “separate” subcategories of cognition would

enable researchers to study cognitive correlations, constraints, tradeoffs, individual cognitive-strategy specializations, potential correlations with personality, and developmental properties that enable successful cognitive functioning in dogs and other animals. Again, information from functional genomics and resulting neurobiological dynamics should prove useful in determining the biological organization of any cognitive modalities.

Dogs are a unique subject species for the study of animal cognition from fundamental and applied standpoints. Their evolutionary history, easy accessibility and behavioral versatility in terms of cognitive paradigms make them an ideal model subject for improving our understanding of the evolution and development of nonsocial and social cognition. At the same time, the impact of dog cognition on important relationships with humans means there is great incentive for better understanding how these animals perceive their environment, process information, and make decisions. It is precisely for these reasons that the canine cognition literature is growing at such a rapid rate. It is our hope that our review can act as a strong foundational starting point for those interested in the topic while also providing some guidance for the next generation of studies.

## ACKNOWLEDGMENTS

We thank Jane Brockman and an anonymous reviewer for their insightful comments on an earlier version of this manuscript, Lilian Bensky for her help in designing, drawing and preparing the figures, Jessica Bensky for her assistance and constructive critiques throughout the writing process, and Scott Thomas for his inspiration regarding dog cognition and working dogs. We are also grateful to James Ha, Ragen T. S. McGowan, Carolyn Loyer, Therese Rehn, Stephen DeBono, Jamie Fratkin, and Monica McGarrity for their thoughtful input on the ideas in the paper. This work was funded, in part, by the U.S. Department of Homeland Security, Science & Technology Directorate research contract HSHQDC-10-C-00085: "Improving the Effectiveness of Detector-Dog Selection and Training through Measurement of Behavior and Temperament."

## REFERENCES

- Adachi, I., Kuwahata, H., & Fujita, K. (2007). Dogs recall their owner's face upon hearing the owner's voice. *Animal Cognition*, *10*, 17–21.
- Adachi, I. (2009). Cross-modal representations in primates and dogs: a new framework of recognition of social objects. *Interaction Studies*, *10*, 225–251.
- Adams, B., Chan, A., Callahan, H., & Milgram, N.W. (2000). The canine as a model of human cognitive aging: recent developments. *Progress in Neuro-psychopharmacology and Biological Psychiatry*, *24*, 675–692.
- Adams, B., Chan, A., Callahan, H., Siwak, C., Tapp, D., Ikeda-Douglas, C., et al. (2000). Use of a delayed non-matching to position task to model age-dependent cognitive decline in the dog. *Behavioural Brain Research*, *108*, 47–56.
- Addressi, E., Paglieri, F., & Focaroli, V. (2011). The ecological rationality of delay tolerance: insights from capuchin monkeys. *Cognition*, *119*, 142–147.

- Adler, L. L., & Adler, H. (1977). Ontogeny of observational learning in the dog (*Canis familiaris*). *Developmental Psychobiology*, *10*, 267–271.
- Agnetta, B., Hare, B., & Tomasello, M. (2000). Cues to food location that domestic dogs (*Canis familiaris*) of different ages do and do not use. *Animal Cognition*, *3*, 107–112.
- Anderson, B. (1993). Evidence in the rat for a general factor that underlies cognitive performance and that relates to brain size: intelligence? *Neuroscience Letters*, *153*, 98–102.
- Araujo, J. A., Chan, A. D. F., Winka, L. L., Seymour, P. A., & Milgram, N. W. (2004). Dose-specific effects of scopolamine on canine cognition: impairment of visuospatial memory, but not visuospatial discrimination. *Psychopharmacology*, *175*, 92–98.
- Ashton, R. L., & De Lillo, C. (2011). Association, inhibition, and object permanence in dogs' (*Canis familiaris*) spatial search. *Journal of Comparative Psychology*, *125*, 194–206.
- Aust, U., & Huber, L. (2001). The role of item- and category-specific information in the discrimination of people- versus nonpeople images by pigeons. *Animal Learning and Behavior*, *29*, 107–119.
- Aust, U., Range, F., Steurer, M., & Huber, L. (2008). Inferential reasoning by exclusion in pigeons, dogs, and humans. *Animal Cognition*, *11*, 587–597.
- Bacon, W. E., & Stanley, W. C. (1968). Avoidance learning in neonatal dogs. *Journal of Comparative and Physiological Psychology*, *71*, 448–452.
- Bacon, W. E., & Stanley, W. C. (1970). Reversal learning in neonatal dogs. *Journal of Comparative and Physiological Psychology*, *70*, 334–350.
- Baillargeon, R. (1987). Young infants reasoning about the physical and spatial properties of a hidden object. *Cognitive Development*, *2*, 179–200.
- Baldwin, D. A. (1993). Early referential understanding: infants' ability to recognize referential acts for what they are. *Developmental Psychology*, *29*, 832–843.
- Barrera, G., Mustaca, A., & Bentosela, M. (2011). Communication between domestic dogs and humans: effects of shelter housing upon the gaze to the human. *Animal Cognition*, *14*, 727–734.
- Bar-Shai, N., Keasar, T., & Shmeada, A. (2011). The use of numerical information in bees in foraging tasks. *Behavioral Ecology*, *22*, 317–325.
- Bateson, P., Hofer, M., Oppenheim, R., & Wiedenmayer, C. (2007). Developing a framework for development: a discussion. *Developmental Psychobiology*, *49*, 77–86.
- Bentosela, M., Barrera, G., Jakovcevic, A., Elgier, A. M., & Mustaca, A. E. (2008). Effect of reinforcement, reinforcer omission and extinction on a communicative response in domestic dogs (*Canis familiaris*). *Behavioural Processes*, *78*, 464–469.
- Bentosela, M., Jakovcevic, A., Elgier, A. M., Mustaca, A. E., & Papini, M. R. (2009). Incentive contrast in domestic dogs (*Canis familiaris*). *Journal of Comparative Psychology*, *123*, 125–130.
- Berns, G. S., Brooks, A. M., & Spivak, M. (2012). Functional MRI in awake unrestrained dogs. *PLoS ONE*, *7*, e38027.
- de Blois, S. T., Novak, M. A., & Bond, M. (1999). Can memory requirements account for species' differences in invisible displacement tasks? *Journal of Experimental Psychology – Animal Behavior Processes*, *25*, 168–176.
- Bloom, P. (2004). Can a dog learn a word? *Science*, *304*, 1605–1606.
- Bonanni, R., Natoli, E., Cafazzo, S., & Valsecchi, P. (2011). Free-ranging dogs assess the quantity of opponents in intergroup conflicts. *Animal Cognition*, *14*, 103–115.
- Bond, A. B., & Kamil, A. C. (1999). Searching image in blue jays: facilitation and interference in sequential priming. *Animal Learning and Behavior*, *27*, 461–471.
- Bratman, M. (1981). Intention and means-end reasoning. *Philosophical Review*, *90*, 252–265.
- Bräuer, J., Bös, M., Call, J., & Tomasello, M. (2012). Domestic dogs (*Canis familiaris*) coordinate their actions in a problem-solving task. *Animal Cognition*. <http://dx.doi.org/10.1007/s10071-012-0571-1>.

- Bräuer, J., & Call, J. (2011). The magic cup: great apes and domestic dogs (*Canis familiaris*) individuate objects according to their properties. *Journal of Comparative Psychology*, *125*, 353–361.
- Bräuer, J., Call, J., & Tomasello, M. (2004). Visual perspective taking in dogs (*Canis familiaris*) in the presence of barriers. *Applied Animal Behaviour Science*, *88*, 299–317.
- Bräuer, J., Kaminski, J., Riedel, J., Call, J., & Tomasello, M. (2006). Making inferences about the location of hidden food: social dog, causal ape. *Journal of Comparative Psychology*, *120*, 38–47.
- Bräuer, J., Keckeisen, M., Pitsch, A., Kaminski, J., Call, J., & Tomasello, M. (2012). Domestic dogs conceal auditory but not visual information from others. *Animal Cognition*. <http://dx.doi.org/10.1007/s10071-012-0576-9>.
- Brooks, S. E., Oi, F. M., & Koehler, P. G. (2003). Ability of canine termite detectors to locate live termites and discriminate them from non-terminate material. *Journal of Economic Entomology*, *96*, 1259–1266.
- Brown, B. L., & Sołtysik, S. (1971). Four-pair same-different differentiation and transient memory in dogs. *Acta Neurobiologiae Experimentalis*, *31*, 87–100.
- Budaev, S., & Brown, C. (2011). Personality traits and behaviour. In C. K. L. Brown & J. Krause (Eds.), *Fish cognition and behaviour* (2nd ed., pp. 135–156). Cambridge, United Kingdom: Blackwell.
- Burghardt, G. M., Bartmess-LeVasseur, J. N., Browning, S. A., Morrison, K. E., Stec, C. L., Zachau, C. E., et al. (2012). Perspectives—minimizing observer bias in behavioral studies: a review and recommendations. *Ethology*, *118*, 511–517.
- Burman, O., McGowan, R., Mendl, M., Norling, Y., Paul, E., Rehn, T., et al. (2011). Using judgement bias to measure positive affective state in dogs. *Applied Animal Behaviour Science*, *132*, 160–168.
- Burns, J. G. (2005). Impulsive bees forage better: the advantage of quick, sometimes inaccurate foraging decisions. *Animal Behaviour*, *70*, e1–e5.
- Buttelmann, D., & Tomasello, M. (2012). Can domestic dogs (*Canis familiaris*) use referential emotional expressions to locate hidden food? *Animal Cognition*. <http://dx.doi.org/10.1007/s10071-012-0560-4>.
- Byrne, R. W. (2002). Emulation in apes: verdict ‘not proven’. *Developmental Science*, *5*, 20–22.
- Cablk, M. E., Sagebiel, J. C., Heaton, J. S., & Valentin, C. (2008). Olfaction-based detection distance: a quantitative analysis of how far away dogs recognize tortoise odor and follow it to source. *Sensors*, *8*, 2208–2222.
- Call, J., Bräuer, J., Kaminski, J., & Tomasello, M. (2003). Domestic dogs (*Canis familiaris*) are sensitive to the attentional state of humans. *Journal of Comparative Psychology*, *117*, 257–263.
- Callahan, H., Ikeda-Douglas, C., Head, E., Cotman, C. W., & Milgram, N. W. (2000). Development of a protocol for studying object recognition memory in dogs. *Progress in Neuro-psychopharmacology and Biological Psychiatry*, *24*, 693–707.
- Carere, C., & Locurto, C. (2011). Interaction between animal personality and animal cognition. *Current Zoology*, *57*, 491–498.
- Carey, S., & Bartlett, E. (1978). Acquiring a single new word. *Papers and Reports on Child Language Development*, *15*, 17–29.
- Caro, T. M., Roper, R., Young, M., & Dank, G. R. (1979). Inter-observer reliability. *Behaviour*, *69*, 303–315.
- Cattet, J., & Etienne, A. S. (2004). Blindfolded dogs relocate a target through path integration. *Animal Behaviour*, *68*, 203–212.
- Chan, A. D. F., Nippak, P. M. D., Murphey, H., Ikeda-Douglas, C. J., Muggenburg, B., Head, E., et al. (2002). Visuospatial impairments in aged canines (*Canis familiaris*): the role of cognitive-behavioral flexibility. *Behavioral Neuroscience*, *116*, 443–454.

- Chapuis, N., Thinus-Blanc, C., & Poucet, B. (1983). Dissociation of mechanisms involved in dogs' oriented displacements. *Quarterly Journal of Experimental Psychology*, *35B*, 213–219.
- Chapuis, N., & Varlet, C. (1987). Short cuts by dogs in natural surroundings. *Quarterly Journal of Experimental Psychology*, *39B*, 49–64.
- Cheke, L. G., & Clayton, N. S. (2010). Mental time travel in animals. *WIREs Cognitive Science*, *1*, 915–930.
- Chittka, L., Dyer, A. G., Bock, F., & Dornhaus, A. (2003). Psychophysics: bees trade off foraging speed for accuracy. *Nature*, *424*, 388.
- Chittka, L., Skorupski, P., & Raine, N. E. (2009). Speed accuracy trade-offs in animal decision making. *Trends in Ecology and Evolution*, *24*, 400–407.
- Christie, L. -A., Studzinski, C. M., Araujo, J. A., Leung, C. S. K., Ikeda-Douglas, C. J., Head, E., et al. (2005). A comparison of egocentric and allocentric age-dependent spatial learning in the beagle dog. *Progress in Neuro-psychopharmacology and Biological Psychiatry*, *29*, 361–369.
- Church, R. M. (2006). Behavioristic, cognitive, biological, and quantitative explanations of timing. In E. A. Wasserman & T. R. Zentall (Eds.), *Comparative cognition* (pp. 249–269). Oxford, United Kingdom: Oxford University Press.
- Clarke, R. S., Heron, W., Fetherstonhaugh, M. L., Forgy, D. G., & Hebb, D. O. (1951). Individual differences in dogs: preliminary report on the effects of early experience. *Canadian Journal of Psychology*, *4*, 150–156.
- Clayton, N. S., & Dickinson, A. (1999). Scrub jays (*Aphelocoma coerulescens*) remember the relative time of caching as well as the location and content of their caches. *Journal of Comparative Psychology*, *113*, 403–416.
- Collier-Baker, E., Davis, J. M., & Suddendorf, T. (2004). Do dogs (*Canis familiaris*) understand invisible displacement? *Journal of Comparative Psychology*, *118*, 421–433.
- Cook, R. G., Wright, A. A., & Drachman, E. E. (2012). Categorization of birds, mammals, and chimeras by pigeons. *Behavioural Processes*. <http://dx.doi.org/10.1016/j.beproc.2012.11.006>.
- Cooper, J., Ashton, C., Bishop, S., West, R., Mills, D. S., & Young, R. J. (2003). Clever hounds: social cognition in the domestic dog (*Canis familiaris*). *Applied Animal Behaviour Science*, *81*, 229–244.
- Coppinger, R., & Coppinger, L. (2001). *Dogs*. Chicago, IL: University of Chicago Press.
- Cracknell, N. R., Mills, D. S., & Kaulfuss, P. (2008). Can stimulus enhancement explain the apparent success of the model-rival technique in the domestic dog (*Canis familiaris*)? *Applied Animal Behaviour Science*, *114*, 461–472.
- Craig, M., Rand, J., Mesch, R., Shyan-Norwalt, M., Morton, J., & Flickinger, E. (2012). Domestic dogs (*Canis familiaris*) and the radial arm maze: spatial memory and serial position effects. *Journal of Comparative Psychology*, *126*, 233–242.
- Crews, D., Fuller, T., Mirasol, E. G., Pfaff, D. W., & Ogawa, S. (2004). Postnatal environment affects behavior of adult transgenic mice. *Experimental Biology and Medicine*, *229*, 935–939.
- Crystal, J. D. (2006). Sensitivity to time: implications to the representation of time. In E. A. Wasserman & T. R. Zentall (Eds.), *Comparative cognition* (pp. 249–269). Oxford, United Kingdom: Oxford University Press.
- Custance, D., & Mayer, J. (2012). Empathetic-like responding by domestic dogs (*Canis familiaris*) to distress in humans: an exploratory study. *Animal Cognition*, *15*, 851–859.
- Dall, S. R. X., Bell, A. M., Bolnick, D. I., & Ratnieks, F. L. W. (2012). An evolutionary ecology of individual differences. *Ecology Letters*, *15*, 1189–1198.
- Dehaene, S., Dehaene-Lambertz, G., & Cohen, L. (1998). Abstract representations of numbers in the animal and human brain. *Trends in Neurosciences*, *21*, 355–361.
- Demant, H., Ladewig, J., Balsby, T. J. S., & Dabelsteen, T. (2011). The effect of frequency and duration of training sessions on acquisition and long-term memory in dogs. *Applied Animal Behaviour Science*, *133*, 228–232.

- Dollaghan, C. (1985). Child meets word: "fast mapping" in preschool children. *Journal of Speech and Hearing Research*, 28, 449–454.
- Domjan, M. (2005). Pavlovian conditioning: a functional perspective. *Annual Review of Psychology*, 56, 179–206.
- Doré, F.Y., & Dumas, C. (1987). Psychology of animal cognition: Piagetian studies. *Psychological Bulletin*, 102, 219–233.
- Doré, F.Y., Fiset, S., Goulet, S., Dumas, M. -C., & Gagnon, S. (1996). Search behavior in cats and dogs: interspecific differences in working memory and spatial cognition. *Animal Learning and Behavior*, 24, 142–149.
- Dorey, N. R., Udell, M. A. R., & Wynne, C. D. L. (2009). Breed differences in dogs sensitivity to human points: a meta-analysis. *Behavioural Processes*, 81, 409–415.
- Dorey, N. R., Udell, M. A. R., & Wynne, C. D. L. (2010). When do domestic dogs, *Canis familiaris*, start to understand human pointing? The role of ontogeny in the development of interspecies communication. *Animal Behaviour*, 79, 37–41.
- Dumas, C. (1998). Figurative and spatial information and search behavior in dogs (*Canis familiaris*). *Behavioural Processes*, 42, 101–106.
- Dumas, C., & Pagé, D. D. (2006). Strategy planning in dogs (*Canis familiaris*) in a progressive elimination task. *Behavioural Processes*, 73, 22–28.
- Elgier, A. M., Jakovcevic, A., Barrera, G., Mustaca, A. E., & Bentosela, M. (2009). Communication between domestic dogs (*Canis familiaris*) and humans: dogs are good learners. *Behavioural Processes*, 81, 402–408.
- Elgier, A. M., Jakovcevic, A., Mustaca, A. E., & Bentosela, M. (2009). Learning and owner-stranger effects on interspecific communication in domestic dogs (*Canis familiaris*). *Behavioural Processes*, 81, 44–49.
- Elgier, A. M., Jakovcevic, A., Mustaca, A. E., & Bentosela, M. (2012). Pointing following in dogs: are simple or complex cognitive mechanisms involved? *Animal Cognition*. <http://dx.doi.org/10.1007/s10071-012-0534-6>.
- Erdőhegyi, Á., Topál, T., Virányi, Z., & Miklósi, Á. (2007). Dog-logic: inferential reasoning in a two-way choice task and its restricted use. *Animal Behaviour*, 74, 725–737.
- Fabrigoule, C., & Sagave, I. (1992). Reorganisation of cues and path organisation in dogs. *Behavioural Processes*, 28, 65–80.
- Faragó, T., Pongrácz, P., Miklósi, Á., Huber, L., Virányi, Z., & Range, F. (2010). Dogs' expectation about signalers' body size by virtue of their growls. *PLoS ONE*, 5, e15175.
- Faragó, T., Pongrácz, P., Range, F., Virányi, Z., & Miklósi, Á. (2010). 'The bone is mine': affective and referential aspects of dog growls. *Animal Behaviour*, 79, 917–925.
- Fetterman, J. G. (1995). The psychophysics of remembered duration. *Animal Learning and Behavior*, 23, 49–62.
- Feuerbacher, E. N., & Wynne, C. D. L. (2011). A history of dogs as subjects in North American experimental psychological research. *Comparative Cognition and Behavior Reviews*, 6, 46–71.
- Fischer, J., Call, J., & Kaminski, J. (2004). A pluralistic account of word learning. *Trends in Cognitive Sciences*, 8, 481.
- Fischer-Tenhagen, C., Wetterholm, L., Tenhagen, B. -A., & Heuwieser, W. (2011). Training dogs on a scent platform for oestrus detection in cows. *Applied Animal Behaviour Science*, 131, 63–70.
- Fiset, S. (2007). Landmark-based search memory in the domestic dog (*Canis familiaris*). *Journal of Comparative Psychology*, 121, 345–353.
- Fiset, S. (2009). Evidence for averaging of distance from landmarks in the domestic dog. *Behavioural Processes*, 81, 429–438.
- Fiset, S. (2010). Comment on "differential sensitivity to human communication in dogs, wolves, and human infants". *Science*, 329, 142b.
- Fiset, S., Beaulieu, C., & Landry, F. (2003). Duration of dogs' (*Canis familiaris*) working memory in search for disappearing objects. *Animal Cognition*, 6, 1–10.

- Fiset, S., Beaulieu, C., LeBlanc, V., & Dubé, L. (2007). Spatial memory of domestic dogs (*Canis familiaris*) for hidden objects in a detour task. *Journal of Experimental Psychology Animal Behavior Processes*, *33*, 497–508.
- Fiset, S., Gagnon, S., & Beaulieu, C. (2000). Spatial encoding of hidden objects in dogs (*Canis familiaris*). *Journal of Comparative Psychology*, *114*, 315–324.
- Fiset, S., Landry, F., & Ouellette, M. (2006). Egocentric search for disappearing objects in domestic dogs: evidence for a geometric hypothesis of direction. *Animal Cognition*, *9*, 1–12.
- Fiset, S., & LeBlanc, V. (2007). Invisible displacement understanding in domestic dogs (*Canis familiaris*): the role of visual cues in search behavior. *Animal Cognition*, *10*, 211–224.
- Fiset, S., & Plourde, V. (2012). Object permanence in domestic dogs (*Canis lupus familiaris*) and gray wolves (*Canis lupus*). *Journal of Comparative Psychology*. <http://dx.doi.org/10.1037/a0030595>.
- Frank, H. (1980). Evolution of canine information processing under conditions of natural and artificial selection. *Zeitschrift für Tierpsychologie – Journal of Comparative Ethology*, *53*, 389–399.
- Frank, H. (2011). Wolves, dogs, rearing and reinforcement: complex interactions underlying species differences in training and problem-solving performance. *Behaviour Genetics*, *41*, 830–839.
- Frank, H., & Frank, M. G. (1982). Comparison of problem-solving performance in six-week-old wolves and dogs. *Animal Behaviour*, *30*, 95–98.
- Frank, H., & Frank, M. G. (1983). Inhibition training in wolves and dogs. *Behavioural Processes*, *8*, 363–377.
- Frank, H., & Frank, M. (1985). Comparative manipulation-test performance in ten-week-old wolves (*Canis lupus*) and Alaskan malamutes (*Canis familiaris*): a Piagetian interpretation. *Journal of Comparative Psychology*, *99*, 266–274.
- Frank, H., Frank, M. G., Hasselbach, L. M., & Littleton, D. M. (1989). Motivation and insight in wolf (*Canis lupus*) and Alaskan malamute (*Canis familiaris*): visual discrimination learning. *Bulletin of the Psychonomic Society*, *27*, 455–458.
- Fratkin, J. L., Sinn, D. L., Patall, E. A., & Gosling, S. D. (2013). Personality consistency in dogs: a meta-analysis. *PLoS ONE*, *8*, e54907.
- Fujita, K., Morisaki, A., Takaoka, A., Maeda, T., & Hori, Y. (2012). Incidental memory in dogs (*Canis familiaris*): adaptive behavioral solution at an unexpected memory test. *Animal Cognition*, *15*, 1055–1063.
- Fukuzawa, M., Mills, D. S., & Cooper, J. J. (2005a). The effect of human command phonetic characteristics on auditory cognition in dogs (*Canis familiaris*). *Journal of Comparative Psychology*, *119*, 117–120.
- Fukuzawa, M., Mills, D. S., & Cooper, J. J. (2005b). More than just a word: non-semantic command variables affect obedience in the domestic dog (*Canis familiaris*). *Applied Animal Behaviour Science*, *91*, 129–141.
- Fuller, J. L. (1966). Transitory effects of experiential deprivation upon reversal learning in dogs. *Psychonomic Science*, *4*, 273–274.
- Furton, K. G., & Myers, L. J. (2001). The scientific foundation and efficacy of the use of canines as chemical detectors for explosives. *Talanta*, *54*, 487–500.
- Gácsi, M., Györi, B., Miklósi, Á., Virányi, Z., Topál, J., & Csányi, V. (2005). Species-specific differences and similarities in the behavior of hand-raised dog and wolf pups in social situations with humans. *Developmental Psychobiology*, *47*, 111–122.
- Gácsi, M., Györi, B., Virányi, Z., Kubinyi, E., Range, F., Belényi, B., et al. (2009). Explaining dog wolf differences in utilizing human pointing gestures: selection for synergistic shifts in the development of some social skills. *PLoS ONE*, *4*, e6584.
- Gácsi, M., Kara, E., Belényi, B., Topál, J., & Miklósi, Á. (2009). The effect of development and individual differences in pointing comprehension of dogs. *Animal Cognition*, *12*, 471–479.



- Gácsi, M., McGreevy, P., Kara, E., & Miklósi, Á. (2009). Effects of selection for cooperation and attention in dogs. *Behavioral and Brain Functions*, *5*, 31.
- Gácsi, M., Miklósi, Á., Varga, O., Topál, J., & Csányi, V. (2004). Are readers of our face readers of our minds? dogs (*Canis familiaris*) show situation-dependent recognition of human's attention. *Animal Cognition*, *7*, 144–153.
- Gagnon, S., & Doré, F. Y. (1992). Search behavior in various breeds of adult dogs (*Canis familiaris*): object permanence and olfactory cues. *Journal of Comparative Psychology*, *106*, 58–68.
- Gagnon, S., & Doré, F. Y. (1993). Search behavior of dogs (*Canis familiaris*) in invisible displacement problems. *Animal Learning and Behavior*, *21*, 246–254.
- Gagnon, S., & Doré, F. Y. (1994). Cross-sectional study of object permanence in domestic puppies (*Canis familiaris*). *Journal of Comparative Psychology*, *108*, 220–232.
- Galef, B. G., & Laland, K. N. (2005). Social learning in animals: empirical studies and theoretical models. *Bioscience*, *55*, 489–499.
- Galibert, F., Quignon, P., Hitte, C., & André, C. (2011). Toward understanding dog evolutionary and domestication history. *Comptes Rendus Biologies*, *334*, 190–196.
- Gallistel, C. R., & Gelman, R. (2000). Non-verbal numerical cognition: from reals to integers. *Trends in Cognitive Sciences*, *4*, 59–65.
- Galsworthy, M. J., Paya-Cano, J. L., Monleón, S., & Plomin, R. (2002). Evidence for general cognitive ability (g) in heterogeneous stock mice and an analysis of potential confounds. *Genes Brain and Behavior*, *1*, 88–95.
- Gaunet, F. (2008). How do guide dogs of blind owners and pet dogs of sighted owners (*Canis familiaris*) ask their owners for food? *Animal Cognition*, *11*, 475–483.
- Gaunet, F. (2010). How do guide dogs and pet dogs (*Canis familiaris*) ask their owners for their toy and for playing? *Animal Cognition*, *13*, 311–323.
- Gaunet, F., & Deputte, B. L. (2011). Functionally referential and intentional communication in the domestic dog: effects of spatial and social contexts. *Animal Cognition*, *14*, 849–860.
- Gazit, I., Goldblatt, A., & Terkel, J. (2005a). Formation of an olfactory search image for explosive odours in sniffer dogs. *Ethology*, *111*, 669–680.
- Gazit, I., Goldblatt, A., & Terkel, J. (2005b). The role of context specificity in learning: the effects of training context on explosives detection in dogs. *Animal Cognition*, *8*, 143–150.
- Gazit, I., & Terkel, J. (2003). Domination of olfaction over vision in explosives detection by dogs. *Applied Animal Behaviour Science*, *82*, 65–73.
- Gergely, G., Bekkering, H., & Király, I. (2002). Rational imitation in preverbal infants. *Nature*, *415*, 755.
- Grassmann, S., Kaminski, J., & Tomasello, M. (2012). How two word-trained dogs integrate pointing and naming. *Animal Cognition*, *15*, 657–665.
- Green, R. J., & Stanton, M. E. (1989). Differential ontogeny of working memory and reference memory in rats. *Behavioral Neuroscience*, *103*, 98–105.
- Griebel, U., & Oller, D. K. (2012). Vocabulary learning in a Yorkshire Terrier: slow mapping of spoken words. *PLoS ONE*, *7*, e30182.
- Györi, B., Gácsi, M., & Miklósi, Á. (2010). Friend or foe: context dependent sensitivity to human behaviour in dogs. *Applied Animal Behaviour Science*, *128*, 69–77.
- Ha, J. C., Mandell, D. J., & Gray, J. (2011). Two-item discrimination and Hamilton search learning in infant pigtailed macaque monkeys. *Behavioural Processes*, *86*, 1–6.
- Hall, N. J., Smith, D. W., & Wynne, C. D. L. Training domestic dogs (*Canis lupus familiaris*) on a novel odor detection in discrete trials. *Learning and Motivation*, in press.
- Hare, B. (2007). From nonhuman to human mind: what changed and why? *Current Directions in Psychological Science*, *16*, 60–64.
- Hare, B., Brown, M., Williamson, C., & Tomasello, M. (2002). The domestication of social cognition in dogs. *Science*, *298*, 1634–1636.
- Hare, B., Call, J., & Tomasello, M. (1998). Communication of food location between human and dog (*Canis familiaris*). *Evolution of Communication*, *2*, 137–159.

- Hare, B., Rosati, A., Kaminski, J., Bräuer, J., Call, J., & Tomasello, M. (2010). The domestication hypothesis for dogs' skills with human communication: a response to Udell et al. (2008) and Wynne et al. (2008). *Animal Behaviour*, *79*, e1–e6.
- Hare, B., & Tomasello, M. (1999). Domestic dogs (*Canis familiaris*) use human and conspecific social cues to locate hidden food. *Journal of Comparative Psychology*, *113*, 173–177.
- Hare, B., & Tomasello, M. (2005). Human-like social skills in dogs? *Trends in Cognitive Sciences*, *9*, 439–444.
- Harper, R. J., Almirall, J. R., & Furton, K. G. (2005). Identification of dominant odor chemicals emanating from explosives for use in developing optimal training aid combinations and mimics for canine detection. *Talanta*, *67*, 313–327.
- Harr, A. L., Gilbert, V. R., & Phillips, K. A. (2009). Do dogs (*Canis familiaris*) show contagious yawning? *Animal Cognition*, *12*, 833–837.
- Hauser, M. (2000). *Wild minds: What animals really think*. London, United Kingdom: Allen Page.
- Hawk, H. W., & Conley, H. H. (1984). Estrus-related odors in milk detected by trained dogs. *Journal of Dairy Science*, *67*, 392–397.
- Hayes, K. J., & Hayes, C. (1952). Imitation in a home-raised chimpanzee. *Journal of Comparative Psychology*, *45*, 450–459.
- Head, E., Callahan, H., Muggenburg, B. A., Cotman, C. W., & Milgram, N. W. (1998). Visual-discrimination learning and  $\beta$ -amyloid accumulation in the dog. *Neurobiology of Aging*, *19*, 415–425.
- Head, E., Cotman, C. W., & Milgram, N. W. (2000). Canine cognition, aging and neuropathology. *Progress in Neuro-psychopharmacology and Biological Psychiatry*, *24*, 671–673.
- Head, E., Mehta, R., Hartley, J., Kameka, M., Cummings, B. J., Cotman, C. W., et al. (1995). Spatial learning and memory as a function of age in the dog. *Behavioral Neuroscience*, *109*, 851–858.
- Heberlein, M., & Turner, D. C. (2009). Dogs, *Canis familiaris*, find hidden food by observing and interacting with a conspecific. *Animal Behaviour*, *78*, 385–391.
- Heffner, H. (1975). Perception of biologically meaningful sounds by dogs. *Journal of Acoustical Society of America*, *58*, S124.
- Helme, A. E., Call, J., Clayton, N. S., & Emery, N. J. (2006). What do bonobos (*Pan paniscus*) understand about physical contact? *Journal of Comparative Psychology*, *120*, 294–302.
- Helton, W. S. (2009). *Canine ergonomics: The science of working dogs*. Baton Rouge, FL: CRC Press.
- Helton, W. S., & Helton, N. S. (2010). Physical size matters in the domestic dog's (*Canis lupus familiaris*) ability to use human pointing cues. *Behavioural Processes*, *85*, 77–79.
- Hepper, P. G., & Wells, D. L. (2005). How many footsteps do dogs need to determine the direction of an odour trails? *Chemical Senses*, *30*, 291–298.
- Hepper, P. G., & Wells, D. L. (2006). Perinatal olfactory learning in the domestic dog. *Chemical Senses*, *31*, 207–212.
- Herrmann, E., & Call, J. (2012). Are there geniuses among the apes? *Philosophical Transactions of the Royal Society of London. Series B, Biological Sciences*, *367*, 2753–2761.
- Herrmann, E., Hernandez-Lloreda, M. V., Call, J., Hare, B., & Tomasello, M. (2009). The structure of individual differences in the cognitive abilities of children and chimpanzees. *Psychological Science*, *21*, 102–110.
- Herrmann, E., & Tomasello, M. (2006). Apes' and children's understanding of cooperative and competitive motives in a communicative situation. *Developmental Science*, *9*, 518–529.
- Hiestand, L. (2011). A comparison of problem-solving and spatial orientation in the wolf (*Canis lupus*) and dog (*Canis familiaris*). *Behavior Genetics*, *41*, 840–857.
- Hills, T., & Hertwig, R. (2011). Why aren't we smarter already: evolutionary trade-offs and cognitive enhancements. *Current Directions in Psychological Science*, *20*, 373–377.
- Hood, B. M. (1995). Gravity rules for 2–4 year-olds? *Cognitive Development*, *10*, 577–598.

- Horn, L., Virányi, Z., Miklósi, Á., Huber, L., & Range, F. (2012). Domestic dogs (*Canis familiaris*) flexibly adjust their human-directed behavior to the actions of their human partners in a problem situation. *Animal Cognition*, *15*, 57–71.
- Horowitz, A. (2009a). Attention to attention in domestic dogs (*Canis familiaris*) dyadic play. *Animal Cognition*, *12*, 107–118.
- Horowitz, A. (2009b). *Inside of a dog: What dogs see, smell, and know*. New York, NY: Scribner.
- Horowitz, A. (2011). Theory of mind in dogs? Examining method and concept. *Learning and Behavior*, *39*, 314–317.
- Howell, T. J., & Bennett, P. C. (2011a). Can dogs (*Canis familiaris*) use a mirror to solve a problem? *Journal of Veterinary Behavior: Clinical Applications and Research*, *6*, 306–312.
- Howell, T. J., & Bennett, P. C. (2011b). Puppy power! Using social cognition research tasks to improve socialization practices for domestic dogs (*Canis familiaris*). *Journal of Veterinary Behavior: Clinical Applications and Research*, *6*, 195–204.
- Howell, T. J., Conduit, R., Toukhsati, S., & Bennett, P. (2012). Auditory stimulus discrimination recorded in dogs, as indicated by mismatch negativity (MMN). *Behavioural Processes*, *89*, 8–13.
- Hübener, F., & Laska, M. (2001). A two-choice discrimination method to assess olfactory performance in pigtailed macaques, *Macaca nemestrina*. *Physiology and Behavior*, *72*, 511–519.
- Huber, L., Range, F., & Virányi, Z. (2012). Dogs imitate selectively, not necessarily rationally: reply to Kaminski et al. (2011). *Animal Behaviour*, *83*, e1–e3.
- Huber, L., Range, F., Voelkl, B., Szucsich, A., Virányi, Z., & Miklósi, Á. (2009). The evolution of imitation: what do the capacities of non-human animals tell us about the mechanisms of imitation? *Philosophical Transactions of the Royal Society of London. Series B, Biological Sciences*, *364*, 2299–2309.
- Ittyerah, M., & Gaunet, F. (2009). The response of guide dogs and pet dogs (*Canis familiaris*) to cues of human referential communication (pointing and gaze). *Animal Cognition*, *12*, 257–265.
- Jakovcevic, A., Elgier, A. M., Mustaca, A. E., & Bentosela, M. (2010). Breed differences in dogs' (*Canis familiaris*) gaze to the human face. *Behavioural Processes*, *84*, 602–607.
- Jakovcevic, A., Mustaca, A., & Bentosela, M. (2012). Do more sociable dogs gaze longer to the human face than less sociable ones? *Behavioural Processes*, *90*, 217–222.
- Jensen, A. R. (1998). Discovery of g. In S. W. Itzkoff (Series Ed.), *The g factor: The science of mental ability* (pp. 18–44). Westport, CT: Praeger.
- Jeziński, T., Sobczyńska, M., Walczak, M., Gorecka-Bruzda, A., & Ensminger, J. (2012). Do trained dogs discriminate individual body odors of women better than those of men? *Journal of Forensic Sciences*, *57*, 647–653.
- Jeziński, T., Walczak, M., & Gorecka, A. (2008). Information-seeking behaviour of sniffer dogs during match-to-sample training in the scent lineup. *Polish Psychological Bulletin*, *39*, 71–80.
- Joly-Mascheroni, R. M., Senju, A., & Shepherd, A. J. (2008). Dogs catch human yawns. *Biology Letters*, *4*, 446–448.
- Jones, A., & Gosling, S. (2005). Temperament and personality in dogs (*Canis familiaris*): a review and evaluation of past research. *Applied Animal Behaviour Science*, *95*, 1–53.
- Kaminski, J., Bräuer, J., Call, J., & Tomasello, M. (2009). Domestic dogs are sensitive to a human's perspective. *Behaviour*, *146*, 979–998.
- Kaminski, J., Call, J., & Fischer, J. (2004). Word learning in a domestic dog: evidence for “fast mapping”. *Science*, *304*, 1682–1683.
- Kaminski, J., Fischer, J., & Call, J. (2008). Prospective object search in dogs: mixed evidence for knowledge of *what* and *where*. *Animal Cognition*, *11*, 367–371.
- Kaminski, J., Neumann, M., Bräuer, J., Call, J., & Tomasello, M. (2011a). Dogs, *Canis familiaris*, communicate with humans to request but not to inform. *Animal Behaviour*, *82*, 651–658.

- Kaminski, J., Nitzschner, M., Wobber, V., Tennie, C., Bräuer, J., Call, J., et al. (2011b). Do dogs distinguish rational from irrational acts? *Animal Behaviour*, *81*, 195–203.
- Kaminski, J., Pitsch, A., & Tomasello, M. (2012a). Dogs steal in the dark. *Animal Cognition*. <http://dx.doi.org/10.1007/s10071-012-0579-6>.
- Kaminski, J., Schulz, L., & Tomasello, M. (2012b). How dogs know when communication is intended for them. *Developmental Science*, *15*, 222–232.
- Kaminski, J., Tempelmann, S., Call, J., & Tomasello, M. (2009b). Domestic dogs comprehend human communication with iconic signs. *Developmental Science*, *12*, 831–837.
- Kaufman, A. B., & Rosenthal, R. (2009). Can you believe my eyes? the importance of interobserver reliability statistics in observations of animal behaviour. *Animal Behaviour*, *78*, 1487–1491.
- Kaulfuss, P., & Mills, D. S. (2008). Neophilia in domestic dogs (*Canis familiaris*) and its implication for studies of dog cognition. *Animal Cognition*, *11*, 553–556.
- Kehoe, E. J. (2008). Discrimination and generalization. In R. Menzel (Vol. Ed.), *Learning theory and behavior*. Vol. 1. of J. Byrne (Ed.), *Learning and Memory: A comprehensive reference* (pp. 123–150). Oxford, United Kingdom: Elsevier.
- Kirkpatrick, K., & Church, R. M. (2003). Tracking of the expected time to reinforcement in temporal conditioning procedures. *Learning and Behavior*, *31*, 3–21.
- Kis, A., Topál, J., Gácsi, M., Range, F., Huber, L., Miklósi, Á., et al. (2012). Does the A-not-B error in adult pet dogs indicate sensitivity to human communication? *Animal Cognition*, *15*, 737–743.
- Klein, E. D., & Zentall, T. R. (2003). Imitation and affordance learning by pigeons (*Columba livia*). *Journal of Comparative Psychology*, *117*, 414–419.
- Kowalska, D. M. (1997). The method of training dogs in auditory recognition memory tasks with trial-unique stimuli. *Acta Neurobiologiae Experimentalis*, *57*, 345–352.
- Kubinyi, E., Miklósi, Á., Topál, J., & Csányi, V. (2003). Social mimetic behavior and social anticipation in dogs: preliminary results. *Animal Cognition*, *6*, 57–63.
- Kubinyi, E., Pongrácz, P., & Miklósi, Á. (2009). Dog as a model for studying conspecific and heterospecific social learning. *Journal of Veterinary Behavior: Clinical Applications and Research*, *4*, 31–41.
- Kubinyi, E., Topál, J., Miklósi, Á., & Csányi, V. (2003). Dogs (*Canis familiaris*) learn from their owners via observation in a manipulation task. *Journal of Comparative Psychology*, *117*, 156–165.
- Kubinyi, E., Virányi, Z., & Miklósi, Á. (2007). Comparative social cognition: from wolf and dog to humans. *Comparative Cognition and Behavior Reviews*, *2*, 26–46.
- Kundey, S. M. A., De Los Reyes, A., Royer, E., Molina, S., Monnier, B., German, R., et al. (2011). Reputation-like inference in domestic dogs (*Canis familiaris*). *Animal Cognition*, *14*, 291–302.
- Kundey, S. M. A., De Los Reyes, A., Taglang, C., Allen, R., Molina, S., Royer, E., et al. (2010). Domesticated dogs (*Canis familiaris*) react to what others can and cannot hear. *Applied Animal Behaviour Science*, *126*, 45–50.
- Kundey, S. M. A., De Los Reyes, A., Taglang, C., Baruch, A., & German, R. (2010). Domesticated dogs' (*Canis familiaris*) use of the solidity principle. *Animal Cognition*, *13*, 497–505.
- Kundey, S. M. A., German, R., De Los Reyes, A., Monnier, B., Swift, P., Delise, J., et al. (2012). Domestic dogs' (*Canis familiaris*) choices in reference to agreement among human informants on location of food. *Animal Cognition*, *15*, 991–997.
- Kupán, K., Miklósi, Á., György, G., & Topál, J. (2011). Why do dogs (*Canis familiaris*) select the empty container in an observational learning task? *Animal Cognition*, *14*, 259–268.
- Kuśmierk, P., & Kowalska, D. M. (1998). Effect of experimental setting on learning and performance of auditory delayed matching-to-sample task in dogs. *Acta Neurobiologiae Experimentalis*, *58*, 291–307.

- Kuśmierk, P., & Kowalska, D. M. (2002). Effect of sound source position on learning and performance of auditory delayed matching-to-sample task in dogs. *Acta Neurobiologiae Experimentalis*, *62*, 251–262.
- Lakatos, G., Dóka, A., & Miklósi, Á. (2007). The role of visual cues in the comprehension of the human pointing signals in dogs. *International Journal of Comparative Psychology*, *20*, 341–350.
- Lakatos, G., Gácsi, M., Topál, J., & Miklósi, Á. (2012). Comprehension and utilization of pointing gestures and gazing in dog-human communication in relatively complex situations. *Animal Cognition*, *15*, 201–213.
- Lakatos, G., Soproni, K., Dóka, A., & Miklósi, Á. (2009). A comparative approach to dogs' (*Canis familiaris*) and human infants' comprehension of various forms of pointing gestures. *Animal Cognition*, *12*, 621–631.
- Landau, B., Smith, L. B., & Jones, S. S. (1988). The importance of shape in early lexical learning. *Cognitive Development*, *3*, 299–321.
- Leonardi, R. J., Vick, S. -J., & Dufour, V. (2012). Waiting for more: the performance of domestic dogs (*Canis familiaris*) on exchange tasks. *Animal Cognition*, *15*, 107–120.
- Lit, L. (2009). Evaluating learning tasks commonly applied in detection dog training. In W. S. Helton (Ed.), *Ergonomics: The science of working dogs* (pp. 99–114). Boca Raton, FL: CRC Press.
- Lit, L., & Crawford, C. A. (2006). Effects of training paradigms on search dog performance. *Applied Animal Behaviour Science*, *98*, 277–292.
- Lit, L., Schweitzer, J. B., & Oberbauer, A. M. (2011). Handler beliefs affect scent detection dog outcomes. *Animal Cognition*, *14*, 387–394.
- Locurto, C., & Scanlon, C. (1998). Individual differences and a spatial learning factor in two strains of mice. *Journal of Comparative Psychology*, *112*, 344–352.
- Loidolt, M., Aust, U., Meran, I., & Huber, L. (2003). Pigeons use item-specific and category-level information in the identification and categorization of human faces. *Journal of Experimental Psychology – Animal Behavior Processes*, *29*, 261–276.
- Lorenzo, N., Wan, T., Harper, R. J., Hsu, Y. -L., Chow, M., Rose, S., et al. (2003). Laboratory and field experiments used to identify *Canis lupus var. familiaris* active odor signature chemicals from drugs, explosives, and humans. *Analytical and Bioanalytical Chemistry*, *376*, 1212–1224.
- MacDonald, D.W., & Carr, G. M. (1995). Variation in dog society: between resource dispersion and social flux. In J. Serpell (Ed.), *The domestic dog: Its evolution, behaviour, and interactions with people* (pp. 199–216). Cambridge, United Kingdom: Cambridge University Press.
- Macpherson, K., & Roberts, W. A. (2010). Spatial memory in dogs (*Canis familiaris*) on a radial maze. *Journal of Comparative Psychology*, *124*, 47–56.
- Maejima, M., Inoue-Murayama, M., Tonosaki, K., Matsuura, N., Kato, S., Saito, Y., et al. (2007). Traits and genotypes may predict the successful training of drug detection dogs. *Applied Animal Behaviour Science*, *107*, 287–298.
- Markman, E. M., & Abelev, M. (2004). Word learning in dogs? *Trends in Cognitive Sciences*, *8*, 479–481.
- Maros, K., Pongrácz, P., Bárdos, G., Molnár, C., Faragó, T., & Miklósi, Á. (2008). Dogs can discriminate barks from different situations. *Applied Animal Behaviour Science*, *114*, 159–167.
- Marshall-Pescini, S., Passalacqua, C., Barnard, S., Valsecchi, P., & Prato-Previde, E. (2009). Agility and search and rescue training differently affects pet dogs' behaviour in socio-cognitive tasks. *Behavioural Processes*, *81*, 416–422.
- Marshall-Pescini, S., Passalacqua, C., Ferrario, A., Valsecchi, P., & Prato-Previde, E. (2011). Social eavesdropping in the domestic dog. *Animal Behaviour*, *81*, 1177–1183.
- Marshall-Pescini, S., Passalacqua, C., Miletto Petrazzini, M. E., Valsecchi, P., & Prato-Previde, E. (2012). Do dogs (*Canis lupus familiaris*) make counterproductive choices because they are sensitive to human ostensive cues? *PLoS ONE*, *7*, e35437.

- Marshall-Pescini, S., Passalacqua, C., Valsecchi, P., & Prato-Previde, E. (2010). Comment on “Differential sensitivity to human communication in dogs, wolves, and human infants”. *Science*, *329*, 142c.
- Marshall-Pescini, S., Prato-Previde, E., & Valsecchi, P. (2011). Are dogs (*Canis familiaris*) misled more by their owners than by strangers in a food choice task? *Animal Cognition*, *14*, 137–142.
- Marshall-Pescini, S., Valsecchi, P., Petak, I., Accorsi, P. A., & Prato-Previde, E. (2008). Does training make you smarter? the effects of training on dogs’ performance (*Canis familiaris*) in a problem solving task. *Behavioural Processes*, *78*, 449–454.
- Matzel, L. D., Han, Y. R., Grossman, H., Karnik, M. S., Patel, D., Scott, N., et al. (2003). Individual differences in the expression of a “general” learning ability in mice. *Journal of Neuroscience*, *23*, 6423–6433.
- McComb, K., Packer, C., & Pusey, A. (1994). Roaring and numerical assessment in contests between groups of female lions (*Panthera leo*). *Animal Behaviour*, *47*, 379–387.
- McConnell, A. R., Brown, C. M., Shoda, T. M., Stayton, L. E., & Colleen, E. M. (2011). Friends with benefits: on the positive consequences of pet ownership. *Journal of Personality and Social Psychology*, *101*, 1239–1252.
- McConnell, P. B. (1990). Acoustic structure and receiver response in domestic dogs, *Canis familiaris*. *Animal Behaviour*, *39*, 897–904.
- McCulloch, M., Jezierski, T., Broffman, M., Hubbard, A., Turner, K., & Janecki, T. (2006). Diagnostic accuracy of canine scent detection in early- and late-stage lung and breast cancers. *Integrative Cancer Therapies*, *5*, 30–39.
- McKinley, J., & Sambrook, T. D. (2000). Use of human-given cues by domestic dogs (*Canis familiaris*) and horses (*Equus caballus*). *Animal Cognition*, *3*, 13–22.
- McKinley, S., & Young, R. J. (2003). The efficacy of the model-rival method when compared with operant conditioning for training domestic dogs to perform a retrieval-selection task. *Applied Animal Behaviour Science*, *81*, 357–365.
- McMahon, S., Macpherson, K., & Roberts, W. A. (2010). Dogs choose a human informant: metacognition in canines. *Behavioural Processes*, *85*, 293–298.
- Melo, A., Lovic, V., Gonzalez, A., Madden, M., Sinopoli, K., & Fleming, A. S. (2006). Maternal and littermate deprivation disrupts maternal behavior and social-learning of food preference in adulthood: tactile stimulation, nest odor, and social rearing prevent these effects. *Developmental Psychobiology*, *48*, 209–219.
- Merola, I., Prato-Previde, E., & Marshall-Pescini, S. (2012a). Dogs’ social referencing towards owners and strangers. *PLoS ONE*, *7*, e47653.
- Merola, I., Prato-Previde, E., & Marshall-Pescini, S. (2012b). Social referencing in dog-owner dyads? *Animal Cognition*, *15*, 175–185.
- Mersmann, D., Tomasello, M., Call, J., Kaminski, J., & Taborsky, M. (2011). Simple mechanisms can explain social learning in domestic dogs (*Canis familiaris*). *Ethology*, *117*, 675–690.
- Mihalick, S. M., Langlois, J. C., Krienke, J. D., & Dube, W. V. (2000). An olfactory discrimination procedure for mice. *Journal of the Experimental Analysis of Behavior*, *73*, 305–318.
- Miklósi, Á. (2008). *Dog behaviour, evolution and cognition*. Oxford, United Kingdom: Oxford University Press.
- Miklósi, Á., Kubinyi, E., Topál, J., Gácsi, M., Virányi, Z., & Csányi, V. (2003). A simple reason for a big difference: wolves do not look back at humans, but dogs do. *Current Biology*, *13*, 763–766.
- Miklósi, Á., Polgárdi, R., Topál, J., & Csányi, V. (1998). Use of experimenter-given cues in dogs. *Animal Cognition*, *1*, 113–121.
- Miklósi, Á., Polgárdi, R., Topál, J., & Csányi, V. (2000). Intentional behaviour in dog-human communication: an experimental analysis of “showing” behaviour in the dog. *Animal Cognition*, *3*, 159–166.

- Miklósi, Á., Pongrácz, P., Lakatos, G., Topál, J., & Csányi, V. (2005). A comparative study of the use of visual communicative signals in interactions between dogs (*Canis familiaris*) and humans and cats (*Felis catus*) and humans. *Journal of Comparative Psychology*, *119*, 179–186.
- Miklósi, Á., & Soproni, K. (2006). A comparative analysis of animals' understanding of the human pointing gesture. *Animal Cognition*, *9*, 81–93.
- Miklósi, Á., & Szabó, D. (2012). Modelling behavioural evolution and cognition in canines: some problematic issues. *Japanese Journal of Animal Psychology*, *62*, 69–89.
- Miklósi, Á., & Topál, J. (2011). On the hunt for the gene of perspective taking: Pitfalls in methodology. *Learning and Behavior*, *39*, 310–313.
- Miklósi, Á., Topál, J., & Csányi, V. (2004). Comparative social cognition: what can dogs teach us? *Animal Behaviour*, *67*, 995–1004.
- Miklósi, Á., Topál, J., & Csányi, V. (2007). Big thoughts in small brains? Dogs as a model for understanding human social cognition. *Cognitive Neuroscience and Neuropsychology*, *18*, 467–471.
- Milgram, N. W. (2003). Cognitive experience and its effect on age-dependent cognitive decline in beagle dogs. *Neurochemical Research*, *28*, 1677–1682.
- Milgram, N. W., Adams, B., Callahan, H., Head, E., Mackay, B., Thirlwell, C., et al. (1999). Landmark discrimination learning in the dog. *Learning and Memory*, *6*, 54–61.
- Milgram, N. W., Head, E., Muggenburg, B., Holowachuk, D., Murphey, H., Estrada, J., et al. (2002). Landmark discrimination learning in the dog: effects of age, an antioxidant fortified food, and cognitive strategy. *Neuroscience and Biobehavioral Reviews*, *26*, 679–695.
- Milgram, N. W., Head, E., Weiner, E., & Thomas, E. (1994). Cognitive functions and aging in the dog: acquisition of nonspatial visual tasks. *Behavioral Neuroscience*, *108*, 57–68.
- Milgram, N. W., Siwak, C. T., Gruet, P., Atkinson, P., Woehrlé, F., & Callahan, H. (2000). Oral administration of adrafinil improves discrimination learning in aged beagle dogs. *Pharmacology Biochemistry and Behavior*, *66*, 301–305.
- Miller, H. C., & Bender, C. (2012). The breakfast effect: dogs (*Canis familiaris*) search more accurately when they are less hungry. *Behavioural Processes*, *91*, 313–317.
- Miller, H. C., Gipson, C. D., Vaughan, A., Rayburn-Reeves, R., & Zentall, T. R. (2009). Object permanence in dogs: invisible displacement in a rotation task. *Psychonomic Bulletin and Review*, *16*, 150–155.
- Miller, H. C., Pattison, K. F., DeWall, C. N., Rayburn-Reeves, R., & Zentall, T. R. (2010). Self-control without a “self”? Common self-control processes in human and dogs. *Psychological Science*, *21*, 534–538.
- Miller, H. C., Rayburn-Reeves, R., & Zentall, T. R. (2009a). Imitation and emulation by dogs using a bidirectional control procedure. *Behavioural Processes*, *80*, 109–114.
- Miller, H. C., Rayburn-Reeves, R., & Zentall, T. R. (2009b). What do dogs know about hidden objects? *Behavioural Processes*, *81*, 439–446.
- Millot, J. L. (1994). Olfactory and visual cues in the interaction systems between dogs and children. *Behavioural Processes*, *33*, 177–188.
- Molnár, C., Pongrácz, P., Faragó, T., Dóka, A., & Miklósi, Á. (2009). Dogs discriminate between barks: the effect of context and identity of the caller. *Behavioural Processes*, *82*, 198–201.
- Morell, V. (2009). Going to the dogs. *Science*, *325*, 1062–1065.
- Moser, E., & McCulloch, M. (2010). Canine scent detection of human cancers: a review of methods and accuracy. *Journal of Veterinary Behavior: Clinical Applications and Research*, *5*, 145–152.
- Müller, C. A., Mayer, C., Dörrenberg, S., Huber, L., & Range, F. (2011). Female but not male dogs respond to a size constancy violation. *Biology Letters*, *7*, 689–691.
- Müller, C. A., Riemer, S., Rosam, C. M., Schösswender, J., Range, R., & Huber, L. (2012). Brief owner absence does not induce negative judgement bias in pet dogs. *Animal Cognition*, *15*, 1031–1035.

- Nagasawa, M., Murai, K., Mogi, K., & Kikusui, T. (2011). Dogs can discriminate human smiling faces from blank expressions. *Animal Cognition*, *14*, 525–533.
- Nagasawa, M., Yetsuzuka, A., Mogi, K., & Kikusui, T. (2012). A new behavioral test for detecting decline of age-related cognitive ability in dogs. *Journal of Veterinary Behavior: Clinical Applications and Research*, *7*, 220–224.
- Nippak, P. M. D., Chan, A. D. F., Campbell, Z., Muggenburg, B., Head, E., Ikeda, D., et al. (2003). Response latency in *Canis familiaris*: mental ability or mental strategy? *Behavioral Neuroscience*, *117*, 1066–1075.
- Nippak, P. M. D., Ikeda-Douglas, C., & Milgram, N. W. (2006). Extensive spatial training does not negate age differences in response latency. *Brain Research*, *1070*, 171–188.
- Nippak, P. M. D., & Milgram, N. W. (2005). An investigation of the relationship between response latency across several cognitive tasks in the beagle dog. *Progress in Neuro-psychopharmacology and Biological Psychiatry*, *29*, 371–377.
- Nitzschner, M., Melis, A. P., Kaminski, J., & Tomasello, M. (2012). Dogs (*Canis familiaris*) evaluate humans on the basis of direct experiences only. *PLoS ONE*, *7*, e46880.
- O'Hara, S. J., & Reeve, A. V. (2011). A test of the yawning contagion and emotional connectedness hypothesis in dogs, *Canis familiaris*. *Animal Behaviour*, *81*, 335–340.
- Olson, M. E. (2012). The developmental renaissance in adaptationism. *Trends in Ecology and Evolution*, *27*, 278–287.
- Osthaus, B., Lea, S. E. G., & Slater, A. M. (2005). Dogs (*Canis familiaris*) fail to show understanding of means–end connections in a string–pulling task. *Animal Cognition*, *8*, 37–47.
- Osthaus, B., Marlow, D., & Ducat, P. (2010). Minding the gap: spatial perseveration error in dogs. *Animal Cognition*, *13*, 881–885.
- Osthaus, B., Slater, A. M., & Lea, S. E. G. (2003). Can dogs defy gravity? a comparison with the human infant and a non–human primate. *Developmental Science*, *6*, 489–497.
- Parker, S. T., & Gibson, K. R. (1977). Object manipulation, tool use and sensorimotor intelligence as feeding adaptation in cebus monkeys and great apes. *Journal of Human Evolution*, *6*, 623–641.
- Parker, H. G., Kim, L. V., Sutter, N. B., Carlson, S., Lorentzen, T. D., Malek, T. B., et al. (2004). Genetic structure of the purebred domestic dog. *Science*, *304*, 1160–1164.
- Parker, H. G., & Ostrander, E. A. (2005). Canine genomics and genetics: running with the pack. *PLoS Genetics*, *1*, 507–513.
- Pasnak, R., Kurkjian, M., & Triana, E. (1988). Assessment of stage 6 object permanence. *Bulletin of the Psychonomic Society*, *26*, 368–370.
- Passalacqua, C., Marshall-Pescini, S., Barnard, S., Lakatos, G., Valsecchi, P., & Prato-Previde, E. (2011). Human–directed gazing in puppies and adult dogs, *Canis lupus familiaris*. *Animal Behaviour*, *82*, 1043–1050.
- Pattison, K. F., Miller, H. C., Rayburn-Reeves, R., & Zentall, T. (2010). The case of the disappearing bone: dogs' understanding of the physical properties of objects. *Behavioural Processes*, *85*, 278–282.
- Pavlov, I. P. (1906). The scientific investigation of the psychical faculties or processes in higher animals. *Science*, *24*, 613–619.
- Petter, M., Musolino, E., Roberts, W. A., & Cole, M. (2009). Can dogs (*Canis familiaris*) detect human deception? *Behavioural Processes*, *82*, 109–118.
- Pettersson, H., Kaminski, J., Herrmann, E., & Tomasello, M. (2011). Understanding of human communicative motives in domestic dogs. *Applied Animal Behaviour Science*, *133*, 235–245.
- Pfiester, M., Koehler, P. G., & Pereira, R. M. (2008). Ability of bed bug–detecting canines to locate live bed bugs and viable bed bug eggs. *Journal of Economic Entomology*, *101*, 1389–1396.
- Pfungst, O. (1907). *Das Pfard des Herr von Olsten (der Kluge Hans), eine Beitrag zur experimentellen Tierund Menschpsychologie*. Leipzig, Germany: Barth.



- Piaget, J. (1936). *La naissance de l'intelligence (The origins of intelligence)*. Neuchatel, Switzerland: Delachaux et Niestle.
- Piaget, J. (1953). *The origin of intelligence in the child*. London, United Kingdom: Routledge and Kegan.
- Pierrzykowska, B., & Sołtysik, S. (1975a). A failure to train the “same-different” differentiation of photic stimuli in dogs. *Acta Neurobiologiae Experimentalis*, 35, 27–38.
- Pierrzykowska, B., & Sołtysik, S. (1975b). Transfer of the “same-different” differentiation task in dogs. *Acta Neurobiologiae Experimentalis*, 35, 39–50.
- Pigliucci, M. (2003). Phenotypic integration: studying the ecology and evolution of complex phenotypes. *Ecology Letters*, 6, 265–272.
- Pilley, J. W., & Reid, A. K. (2011). Border collie comprehends object names as verbal referents. *Behavioural Processes*, 86, 184–195.
- Plomin, R. (1999). Genetics and general cognitive ability. *Nature*, 402(Suppl.), C25–C29.
- Plomin, R. (2001). The genetics of *g* in human and mouse. *Nature Reviews Neuroscience*, 2, 136–141.
- Pongrácz, P., Bánhegyi, P., & Miklósi, Á. (2012). When rank counts—dominant dogs learn better from a human demonstrator in a two—action test. *Behaviour*, 149, 111–132.
- Pongrácz, P., Miklósi, Á., Dóka, A., & Csányi, V. (2003). Successful application of video-projected human images for signaling to dogs. *Ethology*, 109, 809–821.
- Pongrácz, P., Miklósi, Á., Kubinyi, E., Gurobi, K., Topál, J., & Csányi, V. (2001). Social learning in dogs: the effect of a human demonstrator on the performance of dogs in a detour task. *Animal Behaviour*, 62, 1109–1117.
- Pongrácz, P., Miklósi, Á., Kubinyi, E., Topál, J., & Csányi, V. (2003). Interaction between individual experience and social learning in dogs. *Animal Behaviour*, 65, 595–603.
- Pongrácz, P., Miklósi, Á., Timár-Geng, K., & Csányi, V. (2003). Preference for copying unambiguous demonstrations in dogs (*Canis familiaris*). *Journal of Comparative Psychology*, 117, 337–343.
- Pongrácz, P., Miklósi, Á., Timár-Geng, K., & Csányi, V. (2004). Verbal attention getting as a key factor in social learning between dog (*Canis familiaris*) and human. *Journal of Comparative Psychology*, 118, 375–383.
- Pongrácz, P., Miklósi, Á., Vida, V., & Csányi, V. (2005). The pet dogs ability for learning from a human demonstrator in a detour task is independent from the breed and age. *Applied Animal Behaviour Science*, 90, 309–323.
- Pongrácz, P., Vida, V., Bánhegyi, P., & Miklósi, Á. (2008). How does dominance rank status affect individual and social learning performance in the dog (*Canis familiaris*)? *Animal Cognition*, 11, 75–82.
- Prato-Previde, E., Marshall-Pescini, S., & Valsecchi, P. (2008). Is your choice my choice? the owners' effect on pet dogs' (*Canis familiaris*) performance in a food choice task. *Animal Cognition*, 11, 167–174.
- Premack, D., & Woodruff, G. (1978). Does the chimpanzee have a theory of mind? *Behavioral and Brain Sciences*, 1, 515–526.
- Quignon, P., Rimbault, M., Robin, S., & Galibert, F. (2012). Genetics of canine olfaction and receptor diversity. *Mammalian Genome*, 23, 132–143.
- Ramos, D., & Ades, C. (2012). Two-item sentence comprehension by a dog (*Canis familiaris*). *PloS ONE*, 7, e29689.
- Range, F., Aust, U., Steurer, M., & Huber, L. (2008). Visual categorization of natural stimuli by domestic dogs. *Animal Cognition*, 11, 339–347.
- Range, F., Heucke, S. L., Gruber, C., Konz, A., Huber, L., & Virányi, Z. (2009). The effect of ostensive cues on dogs' performance in a manipulative social learning task. *Applied Animal Behaviour Science*, 120, 170–178.
- Range, F., Horn, L., Bugnyar, T., Gajdon, G. K., & Huber, L. (2009). Social attention in keas, dogs, and human children. *Animal Cognition*, 12, 181–192.

- Range, F., Horn, L., Virányi, Z., & Huber, L. (2009). The absence of reward induces inequity aversion in dogs. *Proceedings of the National Academy of Sciences of the United States of America*, *106*, 340–345.
- Range, F., Hentrup, M., & Virányi, Z. (2011). Dogs are able to solve a means-end task. *Animal Cognition*, *14*, 575–583.
- Range, F., Huber, L., & Heyes, C. (2011). Automatic imitation in dogs. *Proceedings of the Royal Society of London. Series B, Biological Sciences*, *278*, 211–217.
- Range, F., Leitner, K., & Virányi, Z. (2012). The influence of the relationship and motivation on inequity aversion in dogs. *Social Justice Research*, *25*, 170–194.
- Range, F., Möslinger, H., & Virányi, Z. (2012). Domestication has not affected the understanding of mean-end connections in dogs. *Animal Cognition*, *15*, 597–607.
- Range, F., Virányi, Z., & Huber, L. (2007). Selective imitation in domestic dogs. *Current Biology*, *17*, 868–872.
- Reger, M. L., Hovda, D. A., & Giza, C. C. (2009). Ontogeny of rat recognition memory measured by the novel object recognition task. *Developmental Psychobiology*, *51*, 672–678.
- Rehn, T., & Keeling, L. J. (2011). The effect of time left alone at home on dog welfare. *Applied Animal Behaviour Science*, *129*, 129–135.
- Reid, R. J. (2009). Adapting to the human world: dogs' responsiveness to our social cues. *Behavioural Processes*, *80*, 325–333.
- Riedel, J., Buttelmann, D., Call, J., & Tomasello, M. (2006). Domestic dogs (*Canis familiaris*) use a physical marker to locate hidden food. *Animal Cognition*, *9*, 27–35.
- Riedel, J., Schumann, K., Kaminski, J., Call, J., & Tomasello, M. (2008). The early ontogeny of human–dog communication. *Animal Behaviour*, *75*, 1003–1014.
- Roberts, W. A., & Macpherson, K. (2011). Theory of mind in dogs: is the perspective-taking task a good test? *Learning and Behavior*, *39*, 303–305.
- Rooijackers, E. F., Kaminski, J., & Call, J. (2009). Comparing dogs and great apes in their ability to visually track object transpositions. *Animal Cognition*, *12*, 789–796.
- van Rooijen, J. (2010). Do dogs and bees possess a 'theory of mind.' *Animal Behaviour*, *79*, e7–e8.
- Rooney, N. J., & Bradshaw, J. W. S. (2006). Social cognition in the domestic dog: behavior of spectators towards participants in interspecific games. *Animal Behaviour*, *72*, 343–352.
- Rossi, A. P., & Ades, C. (2008). A dog at the keyboard: using arbitrary signs to communicate requests. *Animal Cognition*, *11*, 329–338.
- Rossier, J., & Schenk, F. (2003). Olfactory and/or visual cues for spatial navigation through ontogeny: olfactory cues enable the use of visual cues. *Behavioral Neuroscience*, *117*, 412–425.
- Rudy, J. W., Stadler-Morris, S., & Albert, P. (1987). Ontogeny of spatial navigation behaviors in the rat: dissociation of "proximal"- and "distal"-cue-based behaviors. *Behavioral Neuroscience*, *101*, 62–73.
- Ryan, M. J. (2011). Replication in field biology: the case of the frog-eating bat. *Science*, *334*, 1229–1230.
- Salvin, H. E., McGrath, C., McGreevy, P. D., & Valenzuela, M. J. (2012). Development of a novel paradigm for the measurement of olfactory discrimination in dogs (*Canis familiaris*): a pilot study. *Journal of Veterinary Behavior: Clinical Applications and Research*, *7*, 3–10.
- Salvin, H. E., McGreevy, P. D., Sachdev, P. S., & Valenzuela, M. J. (2011). The canine sand maze: an appetitive spatial memory paradigm sensitive to age-related changes in dogs. *Journal of the Experimental Analysis of Behavior*, *95*, 109–118.
- Scheider, L., Grassmann, S., Kaminski, J., & Tomasello, M. (2011). Domestic dogs use contextual information and tone of voice when following a human pointing gesture. *PLoS ONE*, *6*, e21676.
- Scheider, L., Kaminski, J., Call, J., & Tomasello, M. (2012). Do domestic dogs interpret pointing as a command? *Animal Cognition*. <http://dx.doi.org/10.1007/s10071-012-0577-8>.

- Schmidt, F. L., & Hunter, J. (2004). General mental ability in the world of work: occupational attainment and job performance. *Journal of Personality and Social Psychology, 86*, 162–173.
- Schoon, G. (1997). Scent identifications by dogs (*Canis familiaris*): a new experimental design. *Behaviour, 134*, 531–550.
- Schuck-Paim, C., Borsari, A., & Ottoni, E. B. (2009). Means to an end: neotropical parrots manage to pull strings to meet their goals. *Animal Cognition, 12*, 287–301.
- Schwab, C., & Huber, L. (2006). Obey or not obey? dogs (*Canis familiaris*) behave differently in response to attentional states of their owners. *Journal of Comparative Psychology, 120*, 169–175.
- Scott, J. P., & Fuller, J. L. (1965). *Genetics and the social behavior of the dog*. Chicago, IL: University of Chicago Press.
- Séguinot, V., Cattet, J., & Benhamou, S. (1998). Path integration in dogs. *Animal Behaviour, 55*, 787–797.
- Shafiei, N., Gray, M., Viau, V., & Floresco, S. B. (2012). Acute stress induces selective alterations in cost/benefit decision-making. *Neuropsychopharmacology, 37*, 2194–2209.
- Shepherd, W. T. (1915). Tests on adaptive intelligence in dogs and cats, as compared with adaptive intelligence in rhesus monkeys. *American Journal of Psychology, 26*, 211–216.
- Shepherd, W. T. (1919). On sound discrimination in dogs. *American Journal of Psychology, 291*–294.
- Shettleworth, S. J. (2010). *Cognition, evolution, and behavior*. Oxford, United Kingdom: Oxford University Press.
- Shettleworth, S. J. (2012). Modularity, comparative cognition and human uniqueness. *Philosophical Transactions of the Royal Society of London. Series B, Biological Sciences, 367*, 2794–2802.
- Sih, A., & Bell, A. M. (2008). Insights for behavioral ecology from behavioral syndromes. *Advances in the Study of Behavior, 38*, 227–281.
- Sih, A., & Del Giudice, M. (2012). Linking behavioural syndromes and cognition: a behavioural ecology perspective. *Philosophical Transactions of the Royal Society of London. Series B, Biological Sciences, 367*, 2762–2772.
- Silva, K., Bessa, J., & de Sousa, L. (2012). Auditory contagious yawning in domestic dogs (*Canis familiaris*): first evidence for social modulation. *Animal Cognition, 15*, 721–724.
- Sinn, D. L., Gosling, S. D., & Hilliard, S. (2010). Personality and performance in military working dogs: reliability and predictive validity of behavioral tests. *Applied Animal Behaviour Science, 127*, 51–65.
- Slabbert, J. M., & Rasa, O. A. E. (1997). Observational learning of an acquired maternal behaviour pattern by working dog pups: an alternative training method? *Applied Animal Behaviour Science, 53*, 309–316.
- Snigdha, S., Christie, L. -A., De Rivera, C., Araujo, J. A., Milgram, N. W., & Cotman, C. W. (2012). Age and distraction are determinants of performance on a novel visual search task in aged beagle dogs. *Age, 34*, 67–73.
- Somppi, S., Törnqvist, H., Hänninen, L., Krause, C., & Vainio, O. (2012). Dogs do look at images: eye tracking in canine cognition research. *Animal Cognition, 15*, 163–174.
- Soproni, K., Miklósi, Á., Topál, J., & Csányi, V. (2001). Comprehension of human communicative signs in pet dogs (*Canis familiaris*). *Journal of Comparative Psychology, 115*, 122–126.
- Soproni, K., Miklósi, Á., Topál, J., & Csányi, V. (2002). Dogs' (*Canis familiaris*) responsiveness to human pointing gestures. *Journal of Comparative Psychology, 116*, 27–34.
- Spear, N. E., Miller, J. S., & Jagielo, J. A. (1990). Animal memory and learning. *Annual Review of Psychology, 41*, 169–211.
- Stamps, J., & Groothuis, T. G. G. (2010). The development of animal personality: relevance, concepts and perspectives. *Biological Reviews, 85*, 301–325.
- Stanley, W. C., Bacon, W. E., & Fehr, C. (1970). Discriminated instrumental learning in neonatal dogs. *Journal of Comparative Physiology and Psychology, 70*, 335–343.

- Steen, J. B., & Wilsson, E. (1990). How do dogs determine the direction of tracks? *Acta Physiologica Scandinavica*, *139*, 531–534.
- Suddendorf, T., & Busby, J. (2003). Mental time travel in animals? *Trends in Cognitive Sciences*, *7*, 391–396.
- Suddendorf, T., & Corballis, M. C. (2010). Behavioural evidence for mental time travel in nonhuman animals. *Behavioural Brain Research*, *215*, 292–298.
- Szetei, V., Miklósi, Á., Topál, J., & Csányi, V. (2003). When dogs seem to lose their nose: an investigation on the use of visual and olfactory cues in communicative context between dog and owner. *Applied Animal Behaviour Science*, *83*, 141–152.
- Tapp, P. D., Siwak, C. T., Estrada, J., Head, E., Muggenburg, B. A., Cotman, C. W., et al. (2003a). Size and reversal learning in the beagle dog as a measure of executive function and inhibitory control in aging. *Learning and Memory*, *10*, 64–73.
- Tapp, P. D., Siwak, C. T., Estrada, J., Holowachuk, D., & Milgram, N. W. (2003b). Effects of age on measures of complex working memory span in the beagle dog (*Canis familiaris*) using two versions of a spatial list learning paradigm. *Learning and Memory*, *10*, 148–160.
- Tapp, P. D., Siwak, C. T., Head, E., Cotman, C. W., Murphey, H., Muggenburg, B. A., et al. (2004). Concept abstraction in the aging dog: development of a protocol using successive discrimination and size concept tasks. *Behavioural Brain Research*, *153*, 199–210.
- Téglás, E., Gergely, A., Kupán, K., Miklósi, Á., & Topál, J. (2012). Dogs' gaze following is tuned to human communicative signals. *Current Biology*, *22*, 209–212.
- Tennie, C., Glabsch, E., Tempelmann, S., Bräuer, J., Kaminski, J., & Call, J. (2009). Dogs, *Canis familiaris*, fail to copy intransitive actions in third-party contextual imitation tasks. *Animal Behaviour*, *77*, 1491–1499.
- Thompson, W. R., & Heron, W. (1954). The effects of restricting early experience on the problem-solving capacity of dogs. *Canadian Journal of Psychology*, *8*, 17–31.
- Thorndike, E. L. (1911). *Animal intelligence: Experimental studies*. New York, NY: The MacMillan Company.
- Thornton, A., & Lukas, D. (2012). Individual variation in cognitive performance: developmental and evolutionary perspectives. *Philosophical Transactions of the Royal Society of London. Series B, Biological Sciences*, *367*, 2773–2783.
- Tinbergen, N. (1963). On aims and methods of ethology. *Zeitschrift für Tierpsychologie*, *20*, 410–433.
- Topál, J., Byrne, R. W., Miklósi, Á., & Csányi, V. (2006). Reproducing human actions and action sequences: “do as I do!” in a dog. *Animal Cognition*, *9*, 355–367.
- Topál, J., Erdőhegyi, Á., Mányik, R., & Miklósi, Á. (2006). Mindreading in a dog: an adaptation of a primate “mental attribution” study. *International Journal of Psychology and Psychological Therapy*, *6*, 365–379.
- Topál, J., Gergely, G., Erdőhegyi, Á., Csibra, G., & Miklósi, Á. (2009). Differential sensitivity to human communication in dogs, wolves, and human infants. *Science*, *325*, 1269–1272.
- Topál, J., Miklósi, Á., & Csányi, V. (1997). Dog–human relationship affects problem solving behavior in the dog. *Anthrozoös*, *10*, 214–224.
- Topál, J., Miklósi, Á., Gácsi, M., Dóka, A., Pongrácz, P., Kubinyi, E., et al. (2009). The dog as a model for understanding human social behavior. *Advances in the Study of Behavior*, *39*, 71–116.
- Topál, J., Miklósi, Á., Sümegi, Z., & Kis, A. (2010). Response to comments on “differential sensitivity to human communication in dogs, wolves, and human infants.”. *Science*, *329*, 142d.
- Tornick, J. K., Gibson, B. M., Kispert, D., & Wilkinson, M. (2011). Clark's nutcrackers (*Nucifraga columbiana*) use gestures to identify the location of hidden food. *Animal Cognition*, *14*, 117–125.
- Triana, E., & Pasnak, R. (1981). Object permanence in cats and dogs. *Animal Learning and Behavior*, *9*, 135–139.
- Udell, M. A. R., Dorey, N. R., & Wynne, C. D. L. (2008). Wolves outperform dogs in following human social cues. *Animal Behaviour*, *76*, 1767–1773.

- Udell, M. A. R., Dorey, N. R., & Wynne, C. D. L. (2010a). The performance of stray dogs (*Canis familiaris*) living in a shelter on human-guided object-choice tasks. *Animal Behaviour*, *79*, 717–725.
- Udell, M. A. R., Dorey, N. R., & Wynne, C. D. L. (2010b). What did domestication do to dogs? a new account of dogs' sensitivity to human actions. *Biological Reviews*, *85*, 327–345.
- Udell, M. A. R., Dorey, N. R., & Wynne, C. D. L. (2011). Can your dog read your mind? understanding the causes of canine perspective taking. *Learning and Behavior*, *39*, 289–302.
- Udell, M. A. R., Giglio, R. F., & Wynne, C. D. L. (2008). Domestic dogs (*Canis familiaris*) use human gestures but not nonhuman tokens to find hidden food. *Journal of Comparative Psychology*, *122*, 84–93.
- Udell, M. A. R., & Wynne, C. D. L. (2008). A review of domestic dogs' (*Canis familiaris*) human-like behaviors: or why behavior analysts should stop worrying and love their dogs. *Journal of the Experimental Analysis of Behavior*, *89*, 247–261.
- Udell, M. A. R., & Wynne, C. D. L. (2010). Ontogeny and phylogeny: both are essential to human-sensitive behaviour in the genus *Canis*. *Animal Behaviour*, *79*, e9–e14.
- Udell, M. A. R., & Wynne, C. D. L. (2011). Reevaluating canine perspective-taking behavior. *Learning and Behavior*, *39*, 318–323.
- von Uexkull, J. (1934/1957). A stroll through the worlds of animals and men. In C. H. Schiller (Ed.), *Instinctive behavior* (pp. 5–80). New York, NY: International Universities Press.
- Vas, J., Topál, J., Gácsi, M., Miklósi, Á., & Csányi, V. (2005). A friend or an enemy? dogs' reaction to an unfamiliar person showing behavioural cues of threat and friendliness at different times. *Applied Animal Behaviour Science*, *94*, 99–115.
- Vick, S. J., Bovet, D., & Anderson, J. R. (2010). How do African grey parrots (*Psittacus erithacus*) perform on a delay of gratification task? *Animal Cognition*, *13*, 351–358.
- Vila, C. (1997). Multiple and ancient origins of the domestic dog. *Science*, *276*, 1687–1689.
- Virányi, Z., Gácsi, M., Kubinyi, E., Topál, J., Belényi, B., Ujfalussy, D., et al. (2008). Comprehension of human pointing gestures in young human-reared wolves (*Canis lupus*) and dogs (*Canis familiaris*). *Animal Cognition*, *11*, 373–387.
- Virányi, Z., & Range, F. (2011). Evaluating the logic of perspective-taking experiments. *Learning and Behavior*, *39*, 306–309.
- Virányi, Z., Topál, J., Gácsi, M., Miklósi, Á., & Csányi, V. (2004). Dogs respond appropriately to cues of humans' attentional focus. *Behavioural Processes*, *66*, 161–172.
- Virányi, Z., Topál, J., Gácsi, M., Miklósi, Á., & Csányi, V. (2006). A nonverbal test of knowledge attribution: a comparative study on dogs and children. *Animal Cognition*, *9*, 13–26.
- Wan, M., Kubinyi, E., Miklósi, Á., & Champagne, F. (2009). A cross-cultural comparison of reports by German shepherd owners in Hungary and the United States of America. *Applied Animal Behaviour Science*, *121*, 206–213.
- Ward, C., & Smuts, B. B. (2007). Quantity-based judgments in the domestic dog (*Canis lupus familiaris*). *Animal Cognition*, *10*, 71–80.
- Wasserman, E. A., & Zentall, T. R. (Eds.), (2006). *Comparative cognition: Experimental explorations of animal intelligence*. Oxford, United Kingdom: Oxford University Press.
- Watson, J. S., Gergely, G., Csányi, V., Topál, J., Gácsi, M., & Sarkozi, Z. (2001). Distinguishing logic from association in the solution of an invisible displacement task by children (*Homo sapiens*) and dogs (*Canis familiaris*): using negation of disjunction. *Journal of Comparative Psychology*, *115*, 219–226.
- Wells, D., & Hepper, P. G. (2003). Directional tracking in the domestic dog, *Canis familiaris*. *Applied Animal Behaviour Science*, *84*, 297–305.
- Wells, D., & Hepper, P. G. (2006). Prenatal olfactory learning in the domestic dog. *Animal Behaviour*, *72*, 681–686.
- West, R. E., & Young, R. J. (2002). Do domestic dogs show any evidence of being able to count? *Animal Cognition*, *5*, 183–186.

- West-Eberhard, M. J. (2003). *Developmental plasticity and evolution*. Oxford, United Kingdom: Oxford University Press.
- Williams, M., & Johnston, J. M. (2002). Training and maintaining the performance of dogs (*Canis familiaris*) on an increasing number of odor discriminations in a controlled setting. *Applied Animal Behaviour Science*, *78*, 55–65.
- Willis, C. M., Church, S. M., Guest, C. M., Cook, W. A., McCarthy, N., Bransbury, A. J., et al. (2004). Olfactory detection of human bladder cancer by dogs: proof of principle study. *British Medical Journal*, *329*, 1–6.
- Wilsson, E., & Sinn, D. L. (2012). Are there differences between behavioral measurement methods? A comparison of the predictive validity of two ratings methods in a working dog program. *Applied Animal Behaviour Science*, *141*, 158–172.
- Wobber, V., & Hare, B. (2009). Testing the social dog hypothesis: are dogs also more skilled than chimpanzees in non-communicative social tasks? *Behavioural Processes*, *81*, 423–428.
- Wobber, V., Hare, B., Koler-Matznick, J., Wrangham, R., & Tomasello, M. (2009). Breed differences in domestic dogs' (*Canis familiaris*) comprehension of human communicative signals. *Interaction Studies*, *10*, 206–224.
- Wolf, M., & Weissing, F. J. (2012). Animal personalities: consequences for ecology and evolution. *Trends in Ecology and Evolution*, *27*, 452–461.
- Wright, H. F., Mills, D. S., & Pollux, P. M. J. (2012). Behavioural and physiological correlates of impulsivity in the domestic dog (*Canis familiaris*). *Physiology and Behavior*, *105*, 676–682.
- Wynne, C. D. L. (2001). *Animal cognition: The mental lives of animals*. Houndmills, United Kingdom: Palgrave.
- Wynne, C. D. L. (2004). *Do animals think?* Princeton, NJ: Princeton University Press.
- Wynne, C. D. L., Udell, M. A. R., & Lord, K. A. (2008). Ontogeny's impacts on human-dog communication. *Animal Behaviour*, *76*, e1–e4.
- Wyrwicka, W. (1959). Studies of detour behaviour. *Behaviour*, *14*, 240–264.
- Yamamoto, M., Ohtani, N., & Ohta, M. (2011). The response of dogs to attentional focus of human beings: a comparison between guide dog candidates and other dogs. *Journal of Veterinary Behavior: Clinical Applications and Research*, *6*, 4–11.
- van der Zee, E., Zulch, J., & Mills, D. (2012). Word generalization by a dog (*Canis familiaris*): is shape important? *PLoS ONE*, *7*, e49382.
- Zentall, T. R. (2001). Imitation in animals: evidence, function, and mechanisms. *Cybernetics and Systems*, *32*, 53–96.
- Zentall, T. R. (2006). Imitation: definitions, evidence, and mechanisms. *Animal Cognition*, *9*, 335–353.
- Zentall, T. R., Singer, R. A., & Stagner, J. P. (2008). Episodic-like memory: pigeons can report location pecked when unexpectedly asked. *Behavioural Processes*, *79*, 93–98.
- Zilcha-Manu, S., Mikulincer, M., & Shaver, P. R. (2012). Pets as safe havens and secure bases: the moderating role of pet attachment orientations. *Journal of Research in Personality*, *46*, 571–580.